

Approval body for construction products
and types of construction

Bautechnisches Prüfamt

An institution established by the Federal and
Laender Governments



European Technical Assessment

ETA-15/0876
of 22 October 2021

English translation prepared by DIBt - Original version in German language

General Part

Technical Assessment Body issuing the
European Technical Assessment:

Deutsches Institut für Bautechnik

Trade name of the construction product

Nailed Shear Connector X-HVB

Product family
to which the construction product belongs

Nailed shear connector

Manufacturer

Hilti AG
Feldkircherstraße 100
9494 Schaan
FÜRSTENTUM LIECHTENSTEIN

Manufacturing plant

HILTI AG, Herstellwerke

This European Technical Assessment
contains

22 pages including 17 annexes which form an integral
part of this assessment

This European Technical Assessment is
issued in accordance with Regulation (EU)
No 305/2011, on the basis of

EAD 200033-00-0602

This version replaces

ETA-15/0876 issued on 3 June 2016

The European Technical Assessment is issued by the Technical Assessment Body in its official language. Translations of this European Technical Assessment in other languages shall fully correspond to the original issued document and shall be identified as such.

Communication of this European Technical Assessment, including transmission by electronic means, shall be in full. However, partial reproduction may only be made with the written consent of the issuing Technical Assessment Body. Any partial reproduction shall be identified as such.

This European Technical Assessment may be withdrawn by the issuing Technical Assessment Body, in particular pursuant to information by the Commission in accordance with Article 25(3) of Regulation (EU) No 305/2011.

Specific part

1 Technical description of the product

The nailed shear connector X-HVB is an L-shaped metal part that is mechanically attached with powder-actuated fasteners on steel beams of steel-to-concrete composite, as an alternate to welded headed studs, see annexes A1 and A2.

Aside of the use as shear connector for composite beams, nailed shear connectors are also used for the end anchorage of composite decks, see annex A1.

The nailed shear connectors X-HVB can be arranged with or without profiled composite decking, in one or more rows on steel beams of composite beams. Details of positioning of the nailed shear connectors X-HVB can be found in annexes B5 to B8.

The L-shaped sheet metal part is a 2 mm or 2.5 mm thick steel sheeting sheet steel with a fastening and an anchorage leg.

Depending on the thickness of the concrete slab or the height of the composite deck, a distinction is made between the following types of X-HVB fasteners with different lengths of the anchorage leg of the sheet metal part: X HVB 140, X-HVB 125, X-HVB 110, X-HVB 95, X-HVB 80, X-HVB 50 and X-HVB 40 (see annex A2).

The fastening leg of the L-shaped metal part is fastened by 2 powder-actuated fasteners X-ENP-21 HVB to the steel member. The fasteners X-ENP-21 HVB are made of zinc plated carbon steel and comprises of a pin with a shank diameter of 4.5 mm and two metal washers, see annex A2. The washers serve to guide the fastener while it is being driven into the base material and they contribute to the shear resistance. For the execution of the connection with powder-actuated fasteners, the manufacturer's information considering the information in the annexes B1 to B3.

2 Specification of the intended use in accordance with the applicable European Assessment Document

The intended use of the nailed shear connector X-HVB is the dowelling of composite beams and safeguarding of the composite effect of composite decks according to EN 1994-1-1. It can be used in new buildings or in existing buildings with the aim of reinforcing existing floor constructions.

The intended use of the nailed shear connectors comprises composite structures subject to static and quasi-static loading.

The performances given in Section 3 are only valid if the nailed shear connector is used in compliance with the specifications and conditions given in Annexes B1 to B8.

The verifications and assessment methods on which this European Technical Assessment is based lead to the assumption of a working life of the nailed shear connector of at least 50 years. The indications given on the working life cannot be interpreted as a guarantee given by the producer, but are to be regarded only as a means for choosing the right products in relation to the expected economically reasonable working life of the works.

3 Performance of the product and references to the methods used for its assessment

3.1 Mechanical resistance and stability (BWR 1)

Essential characteristic	Performance
Characteristic resistance in solid concrete decks, shear connector orientation parallel to beam axis	See annex C1
Characteristic resistance in solid concrete decks, shear connector orientation perpendicular to beam axis	No performance assessed
Characteristic resistance in composite decks - decking ribs perpendicular to beam axis - shear connector orientation parallel to beam axis	See annex C1
Characteristic resistance in composite decks - decking ribs perpendicular to beam axis - shear connector orientation perpendicular to beam axis	See annex C1, C3 and C4
Characteristic resistance in composite decks - decking ribs parallel to beam axis - shear connector orientation parallel to beam axis	See annex C2
Characteristic resistance in composite decks - decking ribs parallel to beam axis - shear connector orientation perpendicular to beam axis	No performance assessed
Characteristic resistance of end anchorage of composite decks	See annex C4
Characteristic resistance for use in seismic areas under seismic actions according to EN 1998-1	See annex B1
Characteristic resistance in solid concrete decks in renovation application with old metallic iron or steel material with an actual yield strength less than 235 MPa	See annex C3
Application limit	See annex B3, pass

3.2 Safety in case of fire (BWR 2)

Essential characteristic	Performance
Reaction to fire	Class A1 according to EN 13501-1:2007+A1:2009
Resistance to fire	See annex C5

4 Assessment and verification of constancy of performance (AVCP) system applied, with reference to its legal base

In accordance with EAD No. 200033-00-0602, the applicable European legal act is: Decision 1998/214/EC.

The system to be applied is: 2+

5 Technical details necessary for the implementation of the AVCP system, as provided for in the applicable EAD

Technical details necessary for the implementation of the AVCP system are laid down in the control plan deposited with Deutsches Institut für Bautechnik.

Issued in Berlin on 22 October 2021 by Deutsches Institut für Bautechnik

Dr.-Ing. Ronald Schwuchow
Head of Section

beglaubigt:
Bertram

Nailed shear connector X-HVB with powder-actuated fastener X-ENP-21 HVB

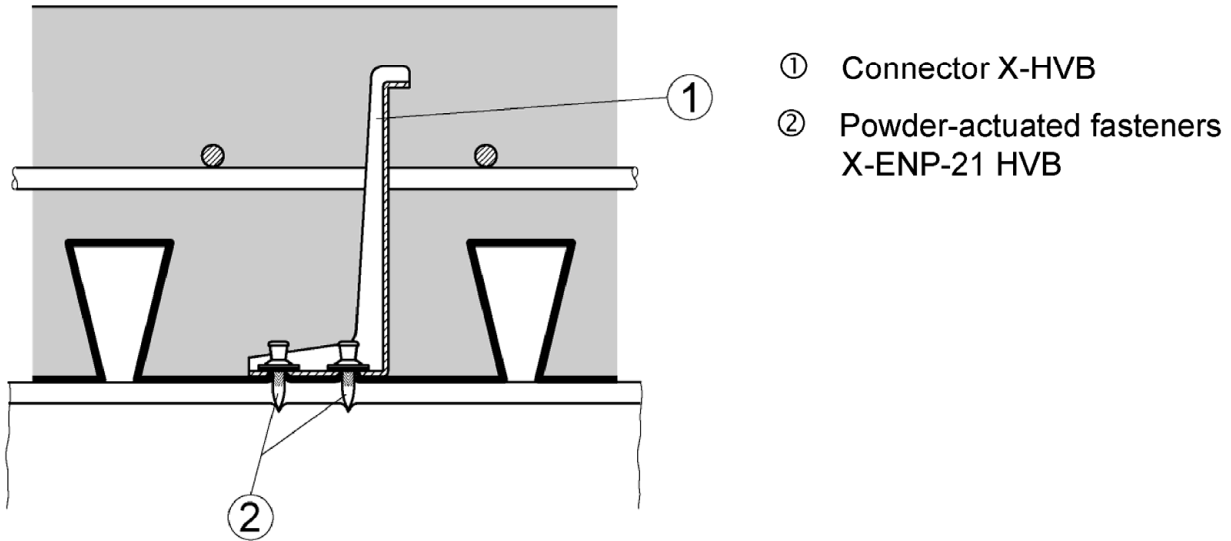

Example of intended use: Nailed shear connection in composite beam

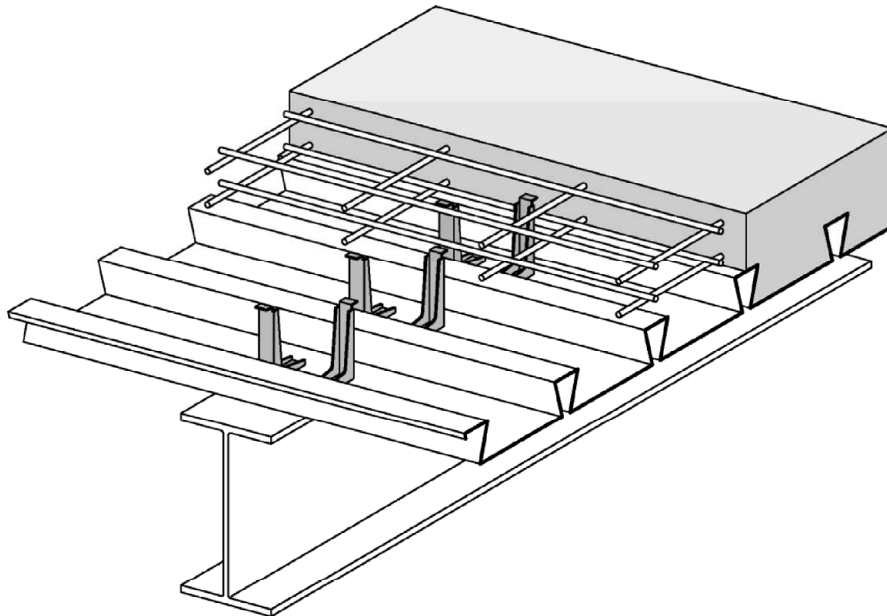

Nailed shear connector X-HVB

Product and intended use

Annex A1

Types of shear connector X-HVB

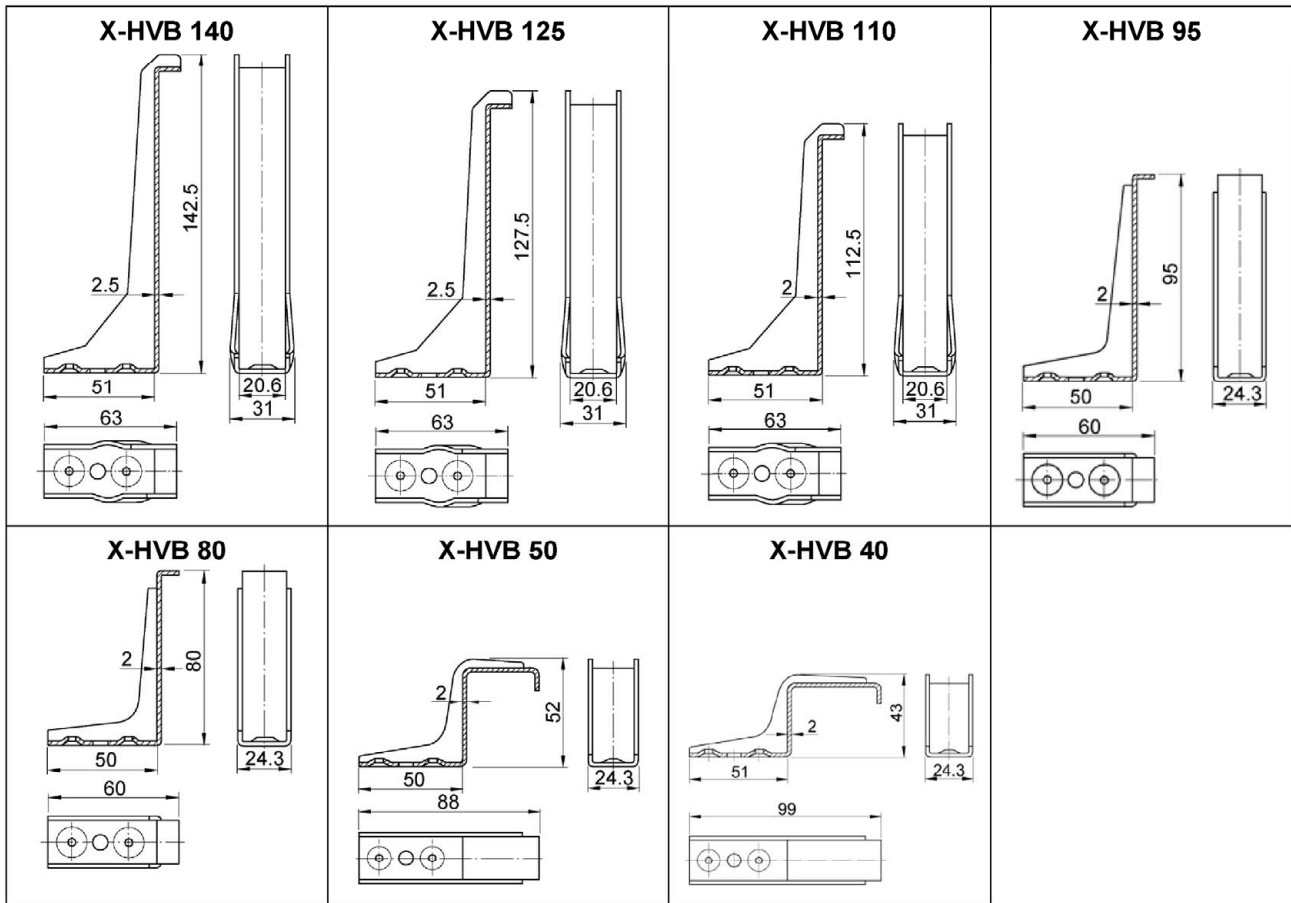
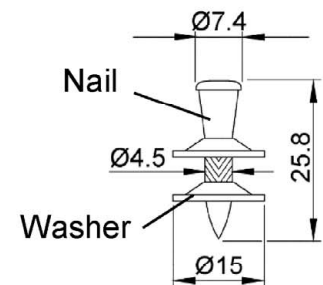

Table 1: Materials

Designation	Material
Shear connector X-HVB	Steel DC04 of a thickness of 2 or 2.5 mm according to EN 10130:2006, zinc plating $\geq 3 \mu\text{m}$
Powder-actuated fastener X-ENP-21 HVB	Nail: Carbon steel C67S in keeping with EN 10132-4:2000/AC:2002, quenched, tempered and galvanized. Nominal hardness: 58 HRC, Zinc plating $\geq 8 \mu\text{m}$ Washer: Steel DC01 according to EN 10139:2016/A1:2020, zinc plating $\geq 10 \mu\text{m}$

Powder-actuated fastener X-ENP-21 HVB



Nailed shear connector X-HVB

Dimensions and materials

Annex A2

Specification of intended use

The nailed shear connector X-HVB is intended to be used as connection device between steel and concrete in composite beams and composite decks according to EN 1994-1-1:2004/AC:2009. The nailed shear connector can either be used in new buildings or for the renovation of existing buildings with the aim to increase the bearing capacity of aged floor constructions.

Shear connections of composite structures subject to:

- Static and quasi-static loading.
- As the X-HVB is a ductile shear connector according to EN 1994-1-1:2004/AC:2009, section 6.6, seismic loading is covered if the X-HVB is used as shear connector in composite beams used as secondary seismic members in dissipative as well as non-dissipative structures according to EN 1998-1:2004/A1:2013.

Base materials:

- Structural steel S235, S275 and S355 in qualities JR, J0, J2, K2 according to EN 10025-2:2019, thickness see Annex B3.
- Old steels which cannot be classified accordingly are still applicable provided these are made of unalloyed carbon steel with minimum yield strength f_y of 170 N/mm².

Concrete:

- Normal weight concrete C20/25 – C50/60 according to EN 206:2013/A2:2021, minimum slab thickness see Annex B4.
- Light weight concrete LC 20/22 – LC 50/55 according to EN 206:2013/A2:2021 with a raw density $\rho \geq 1750$ kg/m³, minimum slab thickness see Annex B4.

Composite decking:

- Steel for profiled sheeting follows EN 1993-1-3:2006/AC:2009 and the material codes given there.

Design:

- Design of the composite beams with X-HVB shear connectors is made according to EN 1994-1-1:2004/AC:2009.
- The X-HVB shear connectors are ductile shear connectors according to EN 1994-1-1:2004/AC:2009, section 6.6.
- The recommended partial factor of $\gamma_V = 1.25$ is used provided no other values are given in national regulations of the member states. For fire design the recommended partial factor $\gamma_{M,fi,V} = 1.0$ is used provided no other value is given in national regulations of the member states.

Installation:

- The installation is only carried out according to the manufacturer's instructions. The powder-actuated fastening tools Hilti DX 76 or Hilti DX 76 PTR as shown in Annex B2 are used to install the X-ENP-21 HVB together with the X-HVB shear connector.
- In combination with composite decking the steel sheeting is in direct contact with the steel base material in the area of the connection. The beams may be hot-dipped galvanized, paint coated or coated with a primer with a coating thickness up to approximately 160 μm . The contact surface of the beam may not be covered with intumescent reactive fire coating.
- Cartridge selection and tool energy settings in order to match the application limit diagram are taken into account, see Annex B3.
- Installation tests are carried out (e.g. check of nail head standoff h_{NVs}), provided the fitness of the recommended cartridge cannot be checked otherwise. Fine regulation of the driving energy by using the wheel on the fastening tool is acceptable in order to meet the nail head standoff h_{NVs} .
- The shear connector X-HVB is properly set if the connector – if applicable together with the profiled metal sheet – is tightened against the steel surface and the nail head standoff h_{NVs} is in accordance with the requirements given in Annex B3. A piston mark on the top washer is clearly visible, see Annex B3.

Nailed shear connector X-HVB	Annex B1
Specification of intended use	

Powder-actuated fastening tools and cartridge 6.8/18M

The driving force of the fastening tools Hilti DX 76 and Hilti DX 76 PTR is provided by the power load of the cartridge. The application limit of the powder-actuated fastening system depends on the strength and thickness of the base material. The fastening tools (incl. cartridges) are an integral part of this assessment with regard to the capacity of the nailed shear connector X-HVB and the application of the respective system.



Powder-actuated fastening tool
DX 76 HVB



Powder-actuated fastening tool
DX 76 PTR HVB



Fastener guide
X-76-F-HVB



Fastener guide
X-76-F-HVB-PTR



Piston
X-76-P-HVB
Buffer: X-76-PS



Piston
X-76-P-HVB-PTR
Buffer: X-76-PS



Detail of wheel on tool allowing continuous regulation of the driving energy within one cartridge colour:
Setting 1: Minimum energy
Setting 4: Maximum energy

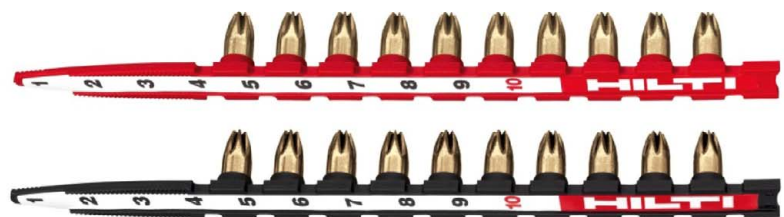

Cartridges 6.8/18 M

Red: Medium high load (energy scale 6)

Black: Extra high load (energy scale 7)

Blue: Medium load (energy scale 5), see Annex B3

Nailed shear connector X-HVB

Powder-actuated fastening tool and components

Annex B2

Application limit and tool energy setting

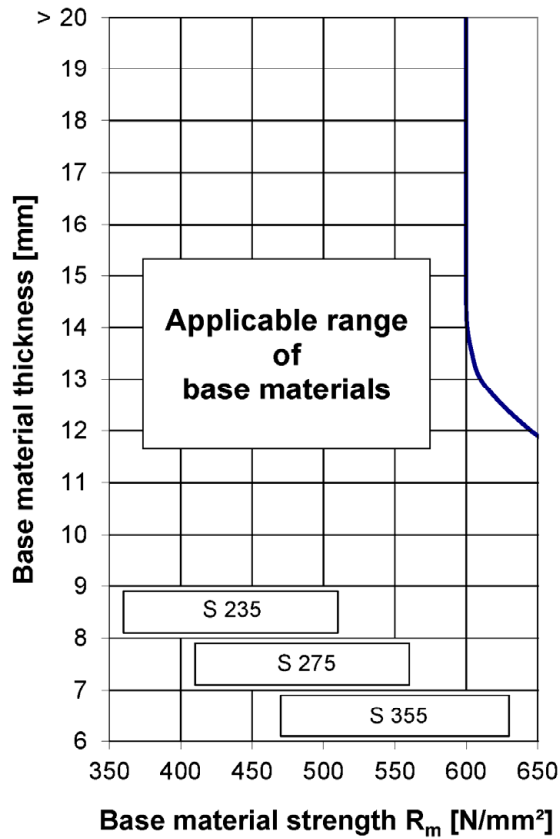

Note:
Minimum section covered: IPE 100 (see Annex C5)

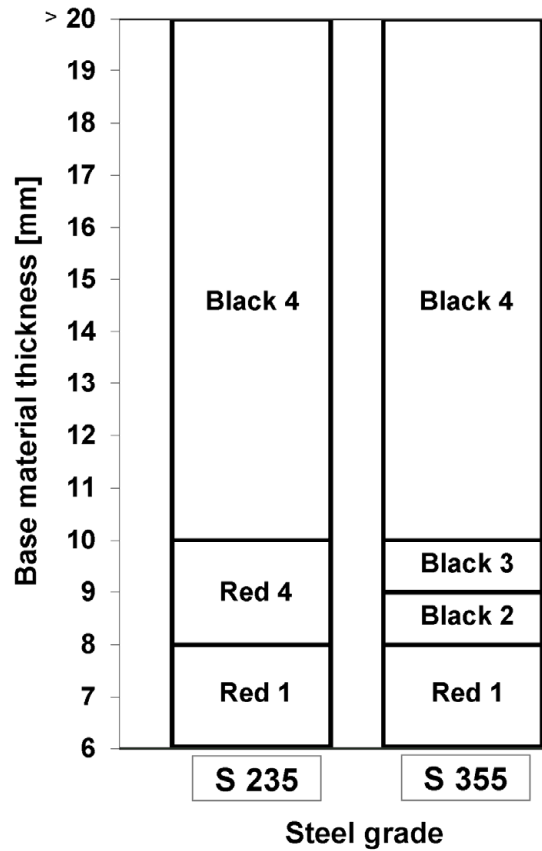

Notes:
In case of thin base materials, the blue cartridge is possible to be used. Blue 3 corresponds to Red 1.
Fine adjustment on the energy based on job site trials.

Fastener inspection

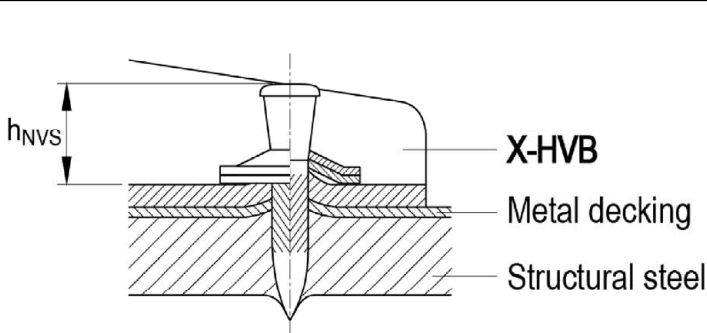

Clearly visible piston mark on top washer

$$8.2 \text{ mm} \leq h_{NVS} \leq 9.8 \text{ mm}$$

Nailed shear connector X-HVB

Application limit, cartridge selection and fastener inspection

Annex B3

Composite decking geometry

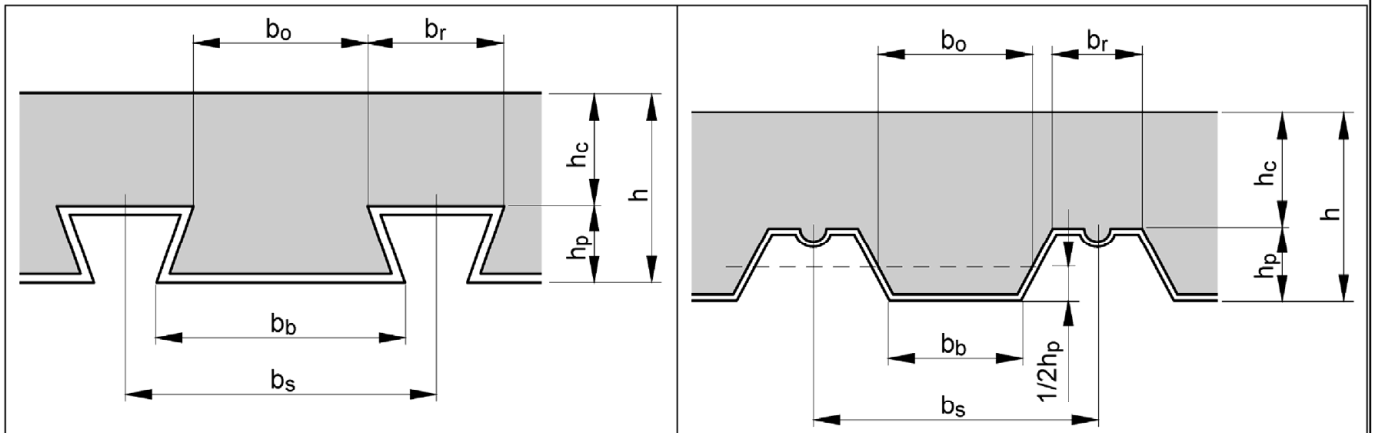

Maximum total thickness of fixed sheeting t_{fix}
 2.0 mm for X-HVB 80, X-HVB 95 and X-HVB 110
 1.5 mm for X-HVB 125 and X-HVB 140

Minimum slab thickness

X-HVB	Minimum slab thickness h [mm]	
	Without effect of corrosion	With effect of corrosion
40	50	60
50	60	70
80	80	100
95	95	115
110	110	130
125	125	145
140	140	160

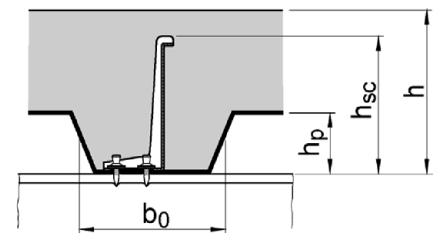

Maximum decking height h_p dependent on decking geometry – general rules

X-HVB	Maximum height of composite decking h_p [mm]		
	$\frac{b_o}{h_p} \geq 1.8$	$1.0 < \frac{b_o}{h_p} < 1.8$	$\frac{b_o}{h_p} \leq 1.0$ ^{x)}
80	45	45	30
95	60	57	45
110	75	66	60
125	80	75	73
140	80	80	80

^{x)} $b_o/h_p \geq 1$ for composite decking perpendicular to beam combined with X-HVB orientation parallel with beam

Nailed shear connector X-HVB

Geometric parameters

Annex B4

**Positioning of X-HVB connectors in solid concrete slabs,
X-HVB are to be positioned parallel with beam**

One row of connectors

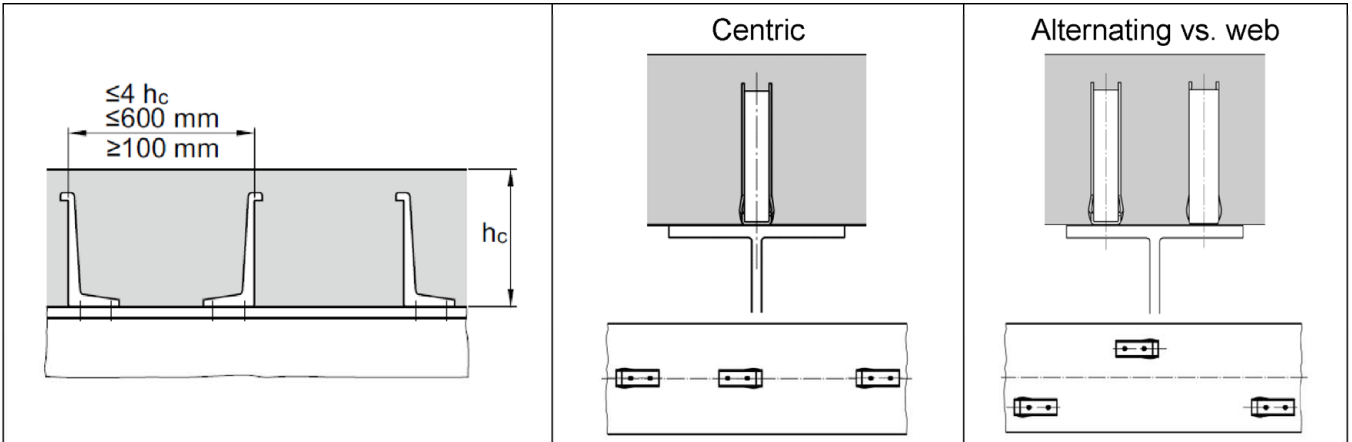

Two rows of connectors

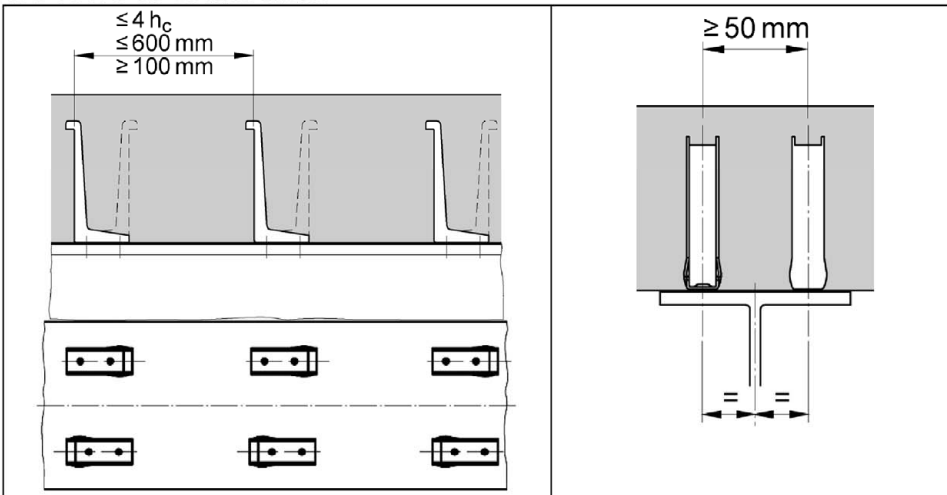

Remark:

When using thin solid concrete slabs in combination with small I-profiles the „duckwalk“ positioning according to Annex C5 applies.

Maximum three rows of connectors

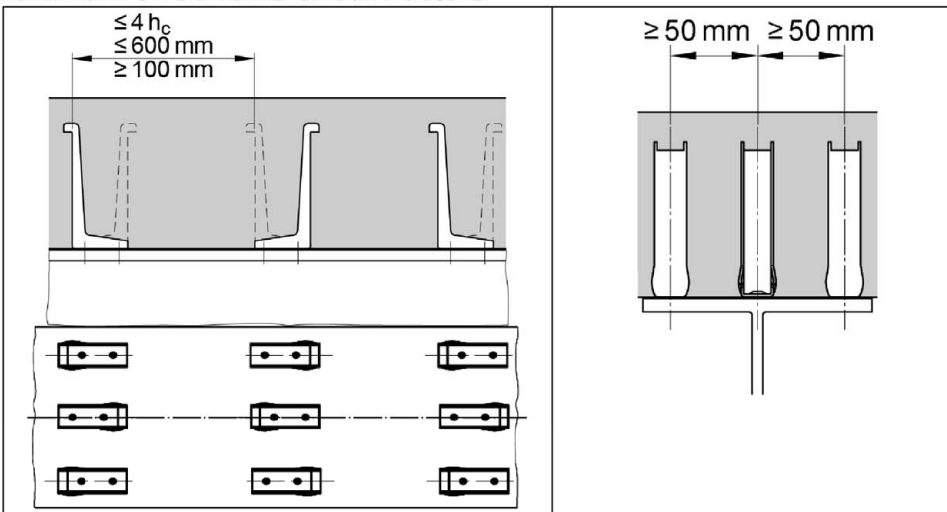

Nailed shear connector X-HVB

Positioning in composite beams with solid concrete slabs

Annex B5

Spacing and positioning within cross section

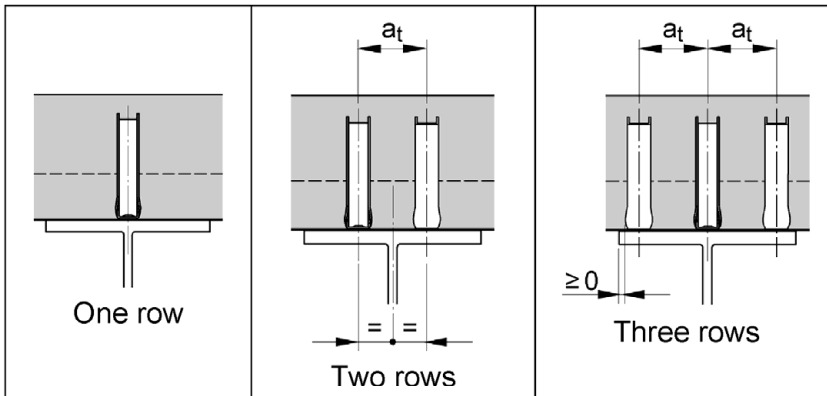

$a_t \geq 50$ mm for compact profiled decking with $b_0/h_p \geq 1.8$
 $a_t \geq 100$ mm for other decking

Minimum rib width and spacing to decking in case of single row positioning

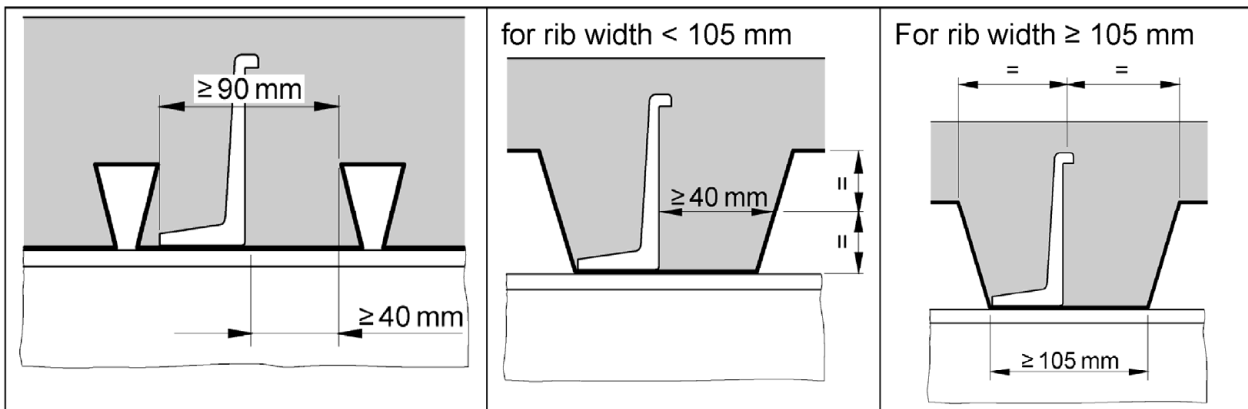

Minimum rib width in case of multiple row positioning

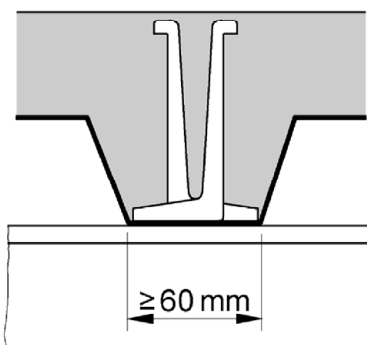

Nailed shear connector X-HVB

Positioning in composite beams with composite decking transverse and X-HVB positioning parallel with beam axis

Annex B6

Spacing and positioning within cross section

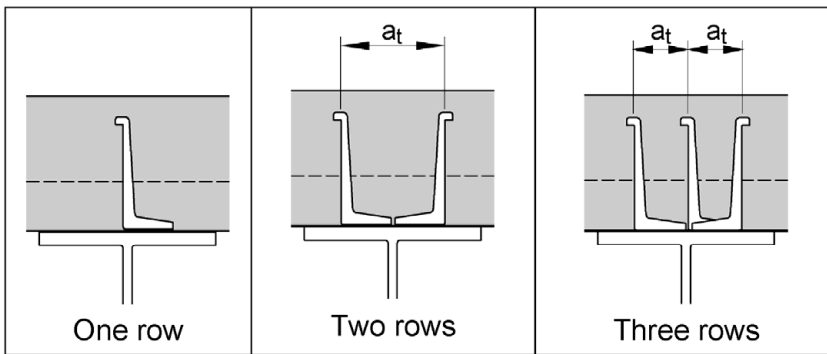

Two rows:
 $a_t \geq 100$ mm for all types decking

Three rows:
 $a_t \geq 50$ mm for compact profiled decking with $b_0/h_p \geq 1.8$
 $a_t \geq 100$ mm for other decking

Positioning in one row with composite deck with or without rib stiffener

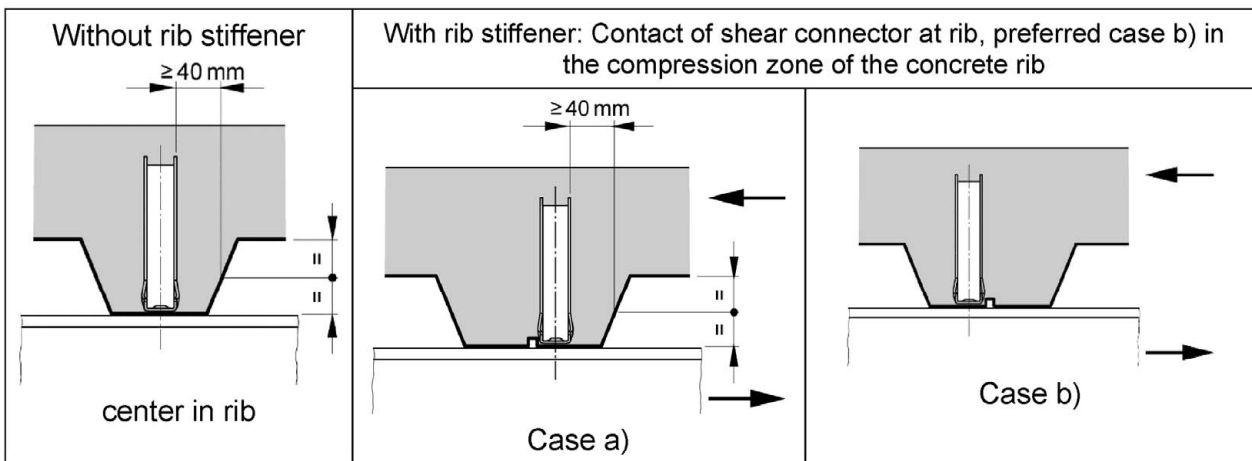

Positioning in two or three rows

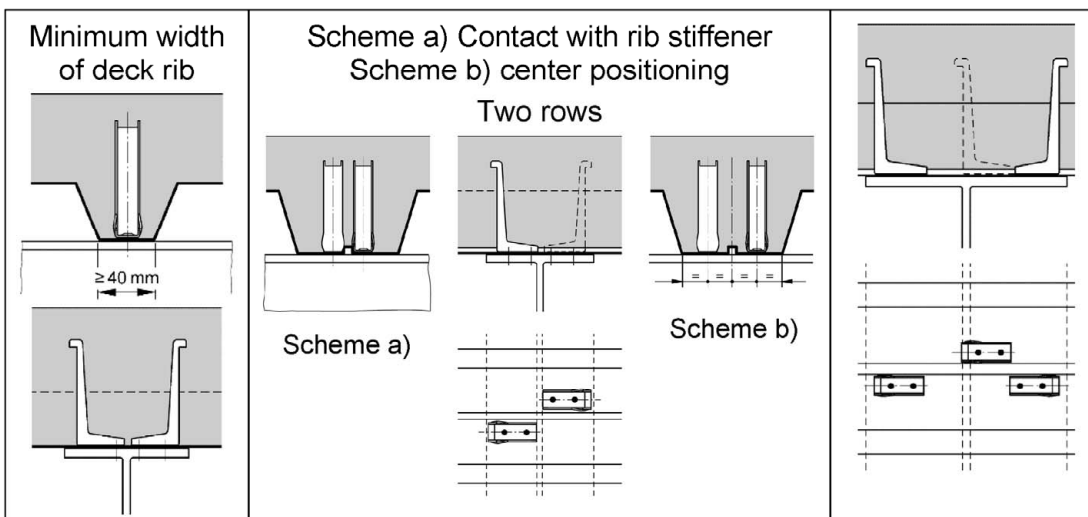

Specific deck geometries deviating from these general rules are addressed in Annex C3 and Annex C4.

Nailed shear connector X-HVB	Annex B7
Positioning in composite beams with composite decking transverse and X-HVB positioning transverse with beam axis	

**Spacing and positioning within cross section,
X-HVB are to be positioned parallel with beam**

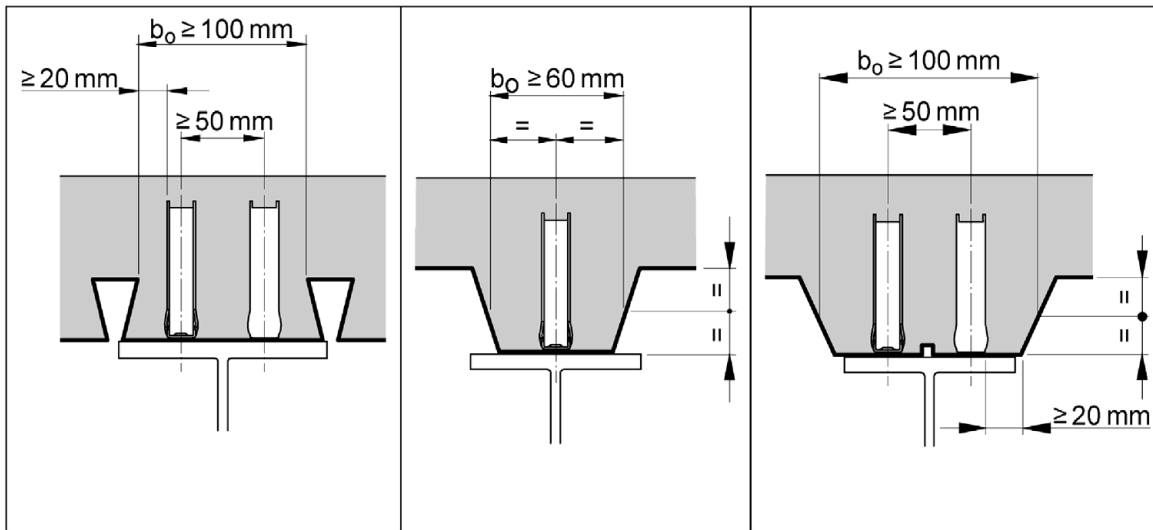

If a centric positioning within the concrete rib is not possible due to the shape of the composite decking, the decking needs to be split:

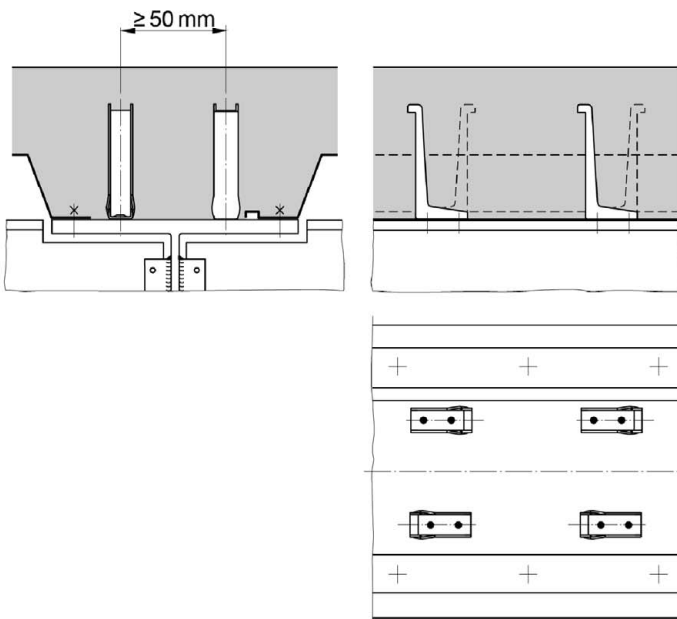

Nailed shear connector X-HVB

Positioning in composite beams with composite decking
parallel with beam axis

Annex B8

Table 3: Characteristic and design¹⁾ resistance in composite beams with solid slabs

Shear Connector	Characteristic Resistance P_{Rk} [kN]	Minimum base material thickness [mm]	X-HVB positioning ³⁾	Ductility assessment
X-HVB 40	29.0	6	"duckwalk"	Ductile according to EN 1994-1-1: 2004/AC:2009
X-HVB 50	29.0	6		
X-HVB 80	32.5	8 ²⁾	parallel with beam	
X-HVB 95	35.0			
X-HVB 110	35.0			
X-HVB 125	37.5			
X-HVB 140	37.5			

1) In the absence of other national regulations a recommended partial factor $\gamma_V = 1.25$ can be used

2) Reduction to 6 mm minimum base material thickness possible, see Annex C5

3) "Duckwalk" positioning according to Annex C5, positioning "parallel with beam" according to Annex B5

Conditions:

- Normal weight concrete C20/25 to C50/60
- Light weight concrete LC20/22 to LC50/55 with a minimum density $\rho = 1750 \text{ kg/m}^3$
- Observation of positioning rules according to Annex B5 and Annex C5

Table 4: Characteristic and design¹⁾ resistance in composite beams with decking ribs transverse to beam axis

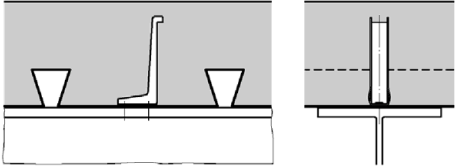
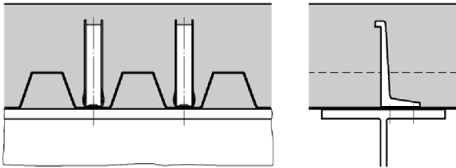
X-HVB positioning	Characteristic Resistance $P_{Rk,t}$	Ductility assessment
 <p>X-HVB positioning longitudinal with the beam</p>	$P_{Rk,t,l} = k_{t,l} \cdot P_{Rk}$ $k_{t,l} = \frac{0.66}{\sqrt{n_r}} \cdot \frac{b_0}{h_p} \cdot \left(\frac{h_{SC}}{h_p} - 1 \right) \leq 1.0$	Ductile according to EN 1994-1-1: 2004/AC:2009
 <p>X-HVB positioning transverse with the beam</p>	$P_{Rk,t,t} = 0.89 \cdot k_{t,t} \cdot P_{Rk}$ $k_{t,t} = \frac{1.18}{\sqrt{n_r}} \cdot \frac{b_0}{h_p} \cdot \left(\frac{h_{SC}}{h_p} - 1 \right) \leq 1.0$	

1) In the absence of other national regulations a recommended partial factor $\gamma_V = 1.25$ can be used

Conditions:

- Characteristic resistance P_{Rk} for solid concrete slabs according to Table 3
- Normal weight concrete C20/25 to C50/60
- Light weight concrete LC20/22 to LC50/55 with a minimum raw density $\rho = 1750 \text{ kg/m}^3$
- Geometric parameters b_0 , h_p and h_{SC} according to Annex B4, n_r corresponds to the number of X-HVBs per rib
- Observation of positioning rules according to Annex B6 and Annex B7
- Applicable for X-HVB 80, X-HVB 95, X-HVB 110, X-HVB 125, X-HVB 140

Nailed shear connector X-HVB	Annex C1
Characteristic and design values of resistance: Solid concrete slabs and composite slabs with decking transverse to beam	

Table 5: Characteristic and design¹⁾ resistance in composite beams with decking ribs parallel to beam axis

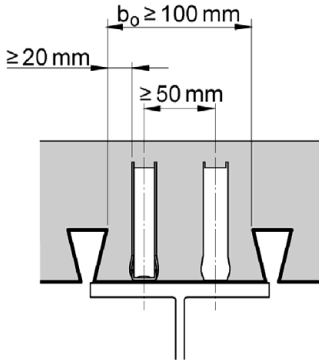
X-HVB positioning	Characteristic Resistance $P_{Rk,l}$	Ductility assessment
 <p>X-HVB positioning longitudinal with the beam</p>	$P_{Rk,l} = k_l \cdot P_{Rk}$ $k_l = 0.6 \cdot \frac{b_0}{h_p} \cdot \left(\frac{h_{sc}}{h_p} - 1 \right) \leq 1.0$	<p>Ductile according to EN 1994-1-1: 2004/AC:2009</p>

¹⁾ In the absence of other national regulations a recommended partial factor $\gamma_V = 1.25$ can be used

Conditions:

- Characteristic resistance P_{Rk} for solid concrete slabs according to Annex C1, Table 3
- X-HVB are to be positioned parallel with beam
- Normal weight concrete C20/25 to C50/60
- Light weight concrete LC20/22 to LC50/55 with a minimum density $\rho = 1750 \text{ kg/m}^3$
- Geometric parameters b_0 , h_p and h_{sc} according to Annex B4
- Observation of positioning rules according to Annex B8
- Applicable for X-HVB 80, X-HVB 95, X-HVB 110, X-HVB 125, X-HVB 140

Nailed shear connector X-HVB	Annex C2
Characteristic and design values of resistance: Composite slabs with decking parallel to beam	

Characteristic and design resistance for decking with narrow ribs on narrow beams and X-HVB transverse to beam axis

Table 6: Characteristic and design¹⁾ resistance

Shear Connector	Number of X-HVB within rib	Type of concrete	Ductility assessment ²⁾	Characteristic Resistance $P_{Rk,t,t}$ [kN]	
X-HVB 95 X-HVB 110 X-HVB 125 X-HVB 140	1	C20/25 – C50/60	Non-ductile	22.7	
			Ductile	17.2	
		LC20/22	Ductile	16.5	
	LC25/28 – LC50/55	17.7			
	2	C20/25 – C50/60	LC20/22	Ductile	14.5
					12.4
13.3					

1) In the absence of other national regulations a recommended partial factor $\gamma_V = 1.25$ can be used

2) according to EN 1994-1-1:2004/AC:2009, section 6.6.1.1

Conditions:

- Normal weight concrete C20/25 to C50/60
- Light weight concrete LC20/22 to LC50/55 with a minimum density $\rho = 1750 \text{ kg/m}^3$
- Minimum base material thickness $t_{fl} = 7.4 \text{ mm}$
- Observation of the following positioning rules and geometric limitations

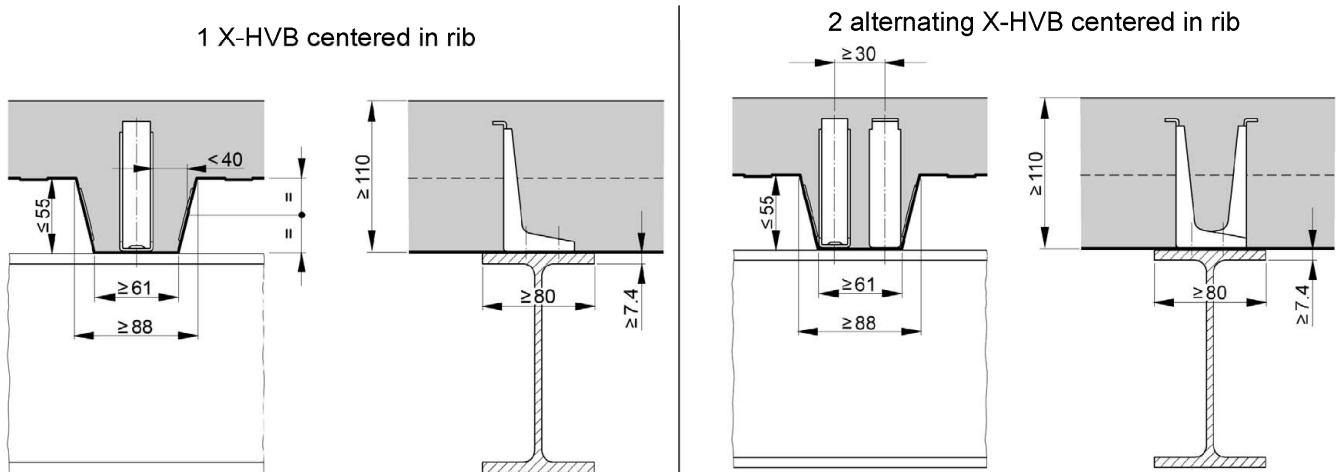

Nailed shear connector X-HVB

Characteristic and design values of resistance: Specific provisions for composite slabs with decking transverse to beam with narrow ribs and narrow beams

Annex C3

Characteristic and design resistance for X-HVB 140 for 80 mm deep decking with 15 mm deep re-entrant stiffener

Table 7: Characteristic and design¹⁾ resistance

Shear Connector	Number of X-HVB within rib	Characteristic Resistance $P_{Rk,t,t}$ [kN]	X-HVB positioning	Ductility assessment
X-HVB 140	1	26.5	transverse to the beam	Ductile according to EN 1994-1-1: 2004/AC:2009
	2	26.5		
	3	24.0		
	4	22.0		

¹⁾ In the absence of other national regulations a recommended partial factor $\gamma_V = 1.25$ can be used

Conditions:

- Normal weight concrete C20/25 to C50/60
- Light weight concrete LC20/22 to LC50/55 with a minimum density $\rho = 1750 \text{ kg/m}^3$
- Minimum base material thickness $t_{bl} = 8 \text{ mm}$
- Observation of the following positioning rules and geometric limitations

Deck geometry:

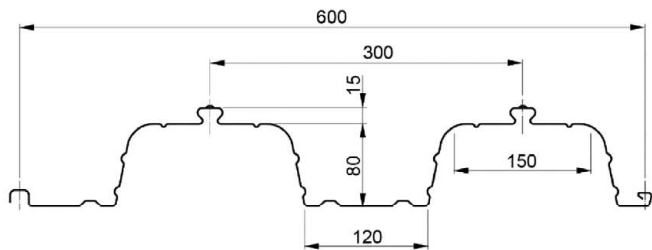

Spacing and positioning within cross section

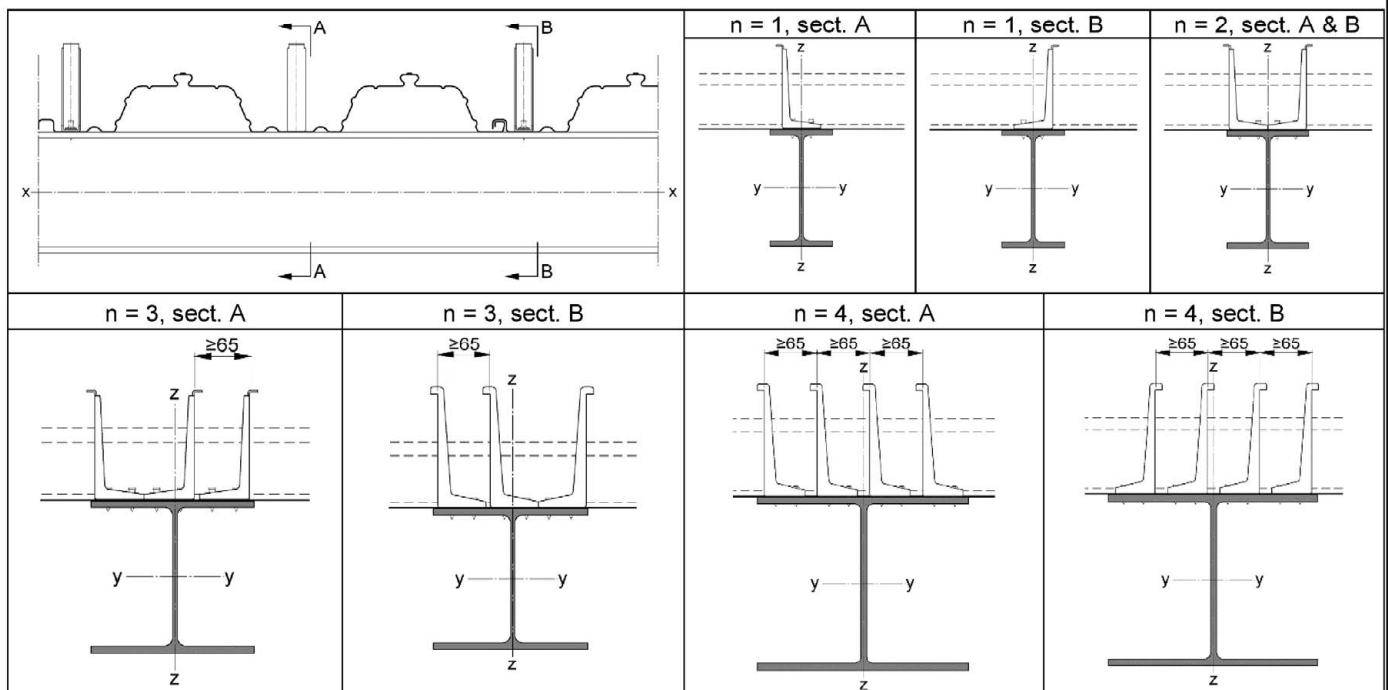

Nailed shear connector X-HVB

Characteristic and design values of resistance of X-HVB 140: Specific provisions for composite slabs with 80 mm deep decking with stiffeners, deck transverse to beam

Annex C4

English translation prepared by DIBt

Characteristic resistance: Effect of reduced base material thickness for X-HVB 80 to X-HVB 140

Reduction of characteristic resistance P_{Rk} with the factor $(t_{II,act} / 8)$ is required in case the actual base material thickness is less than 8 mm.

$$P_{Rk,red} = \frac{t_{II,act}}{8} \cdot P_{Rk}$$

with:

- $P_{Rk,red}$ reduced characteristic resistance of X-HVB 80 to X-HVB 140 for actual base material thickness $t_{II,act} < 8$ mm and a minimum thickness of 6 mm
- P_{Rk} Characteristic resistances in solid and composite slabs for X-HVB 80 to X-HVB 140 according to Annex C1 (Table 3 and 4) and Annex C2

For solid concrete slabs $P_{Rk,red} \geq 29.0$ kN applies.

Notes: Corresponding values can also be applied in new construction.
No extrapolation of above formula for base material thickness $t_{II} > 8$ mm

Characteristic resistance: Effect of reduced base material strength

Reduction of characteristic resistance P_{Rk} with the factor $\alpha_{BM,red}$ is required in case the actual base material f_u strength of the old construction steel is less than 360 N/mm².

Minimum ultimate strength $f_{u,min} = 300$ N/mm² (with a minimum yield strength $f_y = 170$ N/mm²).

$$P_{Rk,red} = \alpha_{BM,red} \cdot P_{Rk}$$

$$\alpha_{BM,red} = 0.95$$

with:

- $P_{Rk,red}$ reduced characteristic strength of X-HVB for base material strength between 300 and 360 N/mm²
- P_{Rk} characteristic resistances of X-HVB according to Annex C1 to Annex C4
- $\alpha_{BM,red}$ base material strength reduction factor

“Duckwalk” positioning of X-HVB 40 and 50 in combination with thin solid slabs:

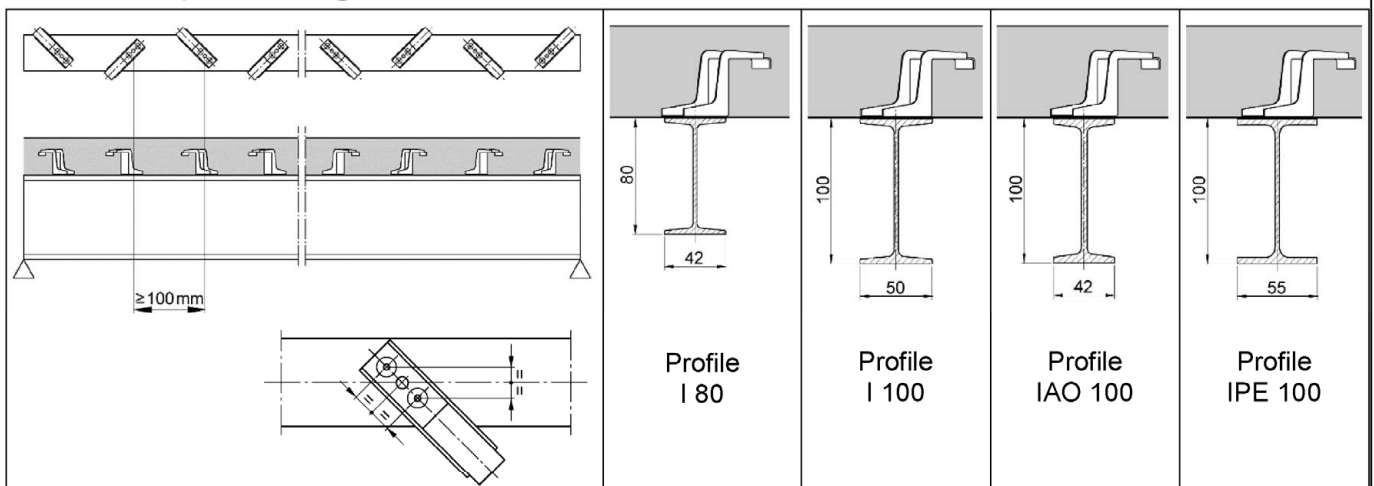

Minimum section width = 40 mm (e.g. old section IAO 100)

Minimum center distance of steel sections = 400 mm

Nailed shear connector X-HVB

Use in renovation construction: characteristic resistance and “duckwalk” positioning

Annex C5

End anchorage in composite slabs

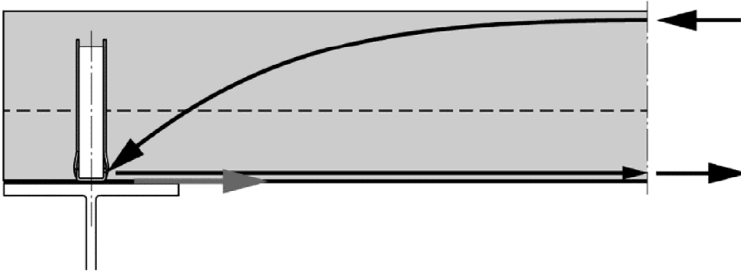

Characteristic and design¹⁾ resistance

$$V_{Rk,EA} = 50 \cdot t \cdot f_{u,k}$$

¹⁾ In the absence of other national regulations a recommended partial factor $\gamma_V = 1.25$ can be used

with:

$V_{Rk,EA}$ characteristic strength of X-HVB 80 to X-HVB 140 for end anchorage of composite decking.

t design core thickness of composite sheet

$f_{u,k}$ characteristic strength of steel composite decking. Independent on the applied steel grade, $f_{u,k}$ used in the formula shall not exceed 360 N/mm²

Nailed shear connector X-HVB	Annex C6
Characteristic and design values of end anchorage of composite slabs	

Table 8: Temperature dependent strength reduction factor

Temperature of top flange Θ_{X-HVB} [°C]	$k_{u,\theta,X-HVB}$
20	1.00
100	1.00
200	0.95
300	0.77
400	0.42
500	0.24
600	0.12
≥ 700	0

The design of the X-HVB shear connector in case of a fire is done according to EN 1994-1-2:2005/A1:2014. The reduction factor $k_{u,\theta,X-HVB}$ shall be determined with the temperature of the steel top flange to which the X-HVB is connected.

The characteristic resistance of the X-HVB nailed shear connector at elevated temperature is calculated:

In case of solid concrete slabs:

$$P_{fi,Rk} = k_{u,\theta,X-HVB} \cdot P_{Rk}$$

with:

$P_{fi,Rk}$ characteristic resistance of X-HVB shear connector at elevated temperature

P_{Rk} characteristic resistance of X-HVB shear connector according to Annex C1, Table 3

In case of composite beams with decking ribs transverse to the beam:

$$P_{fi,Rk} = k_{u,\theta,X-HVB} \cdot k_{t,l} \cdot P_{Rk} \quad \text{or} \quad P_{fi,Rk} = 0.89 \cdot k_{u,\theta,X-HVB} \cdot k_{t,t} \cdot P_{Rk}$$

with:

$P_{fi,Rk}$ characteristic resistance of X-HVB shear connector at elevated temperature

P_{Rk} characteristic resistance of X-HVB shear connector according to Annex C1, Table 3

$k_{t,l}$ or $k_{t,t}$.. reduction factor according to Annex C1, Table 4

Provision for deck types covered by Annex C3 and Annex C4: $P_{fi,Rk} = k_{u,\theta,X-HVB} \cdot P_{Rk}$

In case of composite beams with decking ribs parallel to the beam:

$$P_{fi,Rk} = k_{u,\theta,X-HVB} \cdot k_l \cdot P_{Rk}$$

with:

$P_{fi,Rk}$ characteristic resistance of X-HVB shear connector at elevated temperature

P_{Rk} characteristic resistance of X-HVB shear connector according to Annex C1, Table 3

k_l ... reduction factor according to Annex C2, Table 5

$k_{u,\theta,X-HVB}$ temperature dependent reduction factor according to Table 8

1) In the absence of other national regulations a recommended partial factor $\gamma_{M,fi,V} = 1.0$ can be used

Nailed shear connector X-HVB	Annex C7
Characteristic and design resistance to fire	