



EUROPEAN TECHNICAL ASSESSMENTS

Safety in case of fire

**Fire Resistant Solutions for
Modular Support Systems**

Version 1.1

09.2018



Safety in Case of Fire

Worldwide fire events endanger human life, harm the environment and cause significant economic losses.

The overriding objective in terms of fire safety is to ultimately avoid fire events or in case they occur to minimize their consequences.

Most importantly this involves protecting human life, the environment, buildings facilities and critical technical equipment that supports a fast and safe evacuation.

Technical and organizational safety measures for protecting assets and their users are an integral part of the planning process. Designing fire-resistant support solutions is a crucial task for all planners, architects and engineers, since significant deformations due to the exposure to fire can occur, causing considerable damages and eventually a total collapse of these critical systems.

Despite its importance, so far, there was not a harmonized and trusted design methodology for fire-resistant support systems. Even the widely-used Eurocode 3 has been proven inappropriate to predict the real deformation behavior of thin metal profiles by current academic and industry research. Furthermore, other design methodologies frequently lead to non-flexible, over-engineered and thus also not cost-effective solutions.

To overcome these pressing problems, Hilti in cooperation with industry experts, leading fire institutes, DIBt and EOTA, has worked on creating the EAD (European Assessment Document) fire-resistant design and testing guideline aiming to help the industry professional with a safe solution, to reduce the design time, to increase flexibility and consequently reduce the costs involved.







A comprehensive verification concept at a component level has been developed with a combination of fire tests and calculations using adjusted material models. With this, the behavior in case of fire of modular support systems is now predictable for any combination of the tested components.





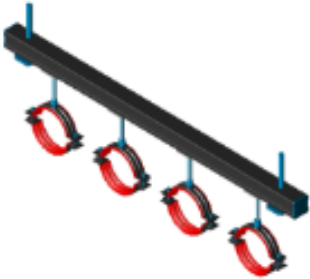

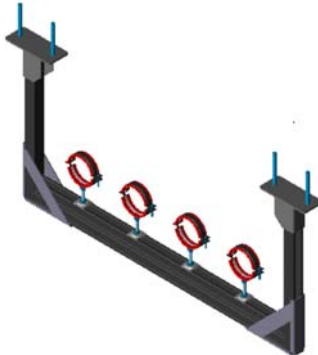
As a result, an extensive range of fully ETA (European Technical Assessment) compliant MEP (Mechanical, Electrical, Plumbing) applications and products are now available including all necessary documentation.

Hilti offers innovative, safe, practical and legally compliant solutions for fire-resistant modular support systems.

Peter Rupp
Head of Business Unit Installation Systems
Hilti Corporation
Schaan | Principality of Liechtenstein

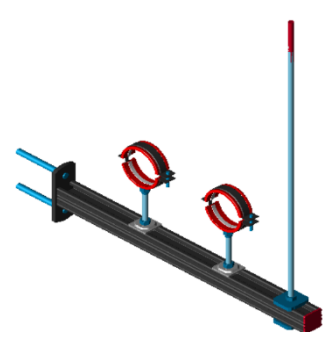

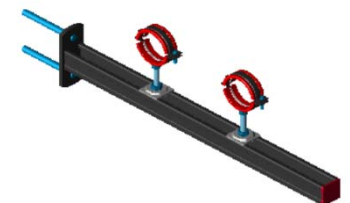
Configuration	System component	ETA number
<p>Trapeze rod</p>  	Threaded rod	ETA-18/0131
	Channel	ETA-18/0119
	Drilled plate	ETA-18/0102
	Pipe-clamp	ETA-18/0130
	Pipe-clamp saddle nut Pipe-clamp drilled plate	ETA-18/0132 ETA-18/0102
	Anchor	See Anchor ETAs
<p>Headrail</p>  	Threaded rod	ETA-18/0131
	Channel	ETA-18/0119
	Drilled plate	ETA-18/0102
	Pipe-clamp	ETA-18/0130
	Pipe-clamp saddle nut	ETA-18/0132
	Anchor	ETA-17/1067 ETA-18/0119
<p>Trapeze frame</p>  	Trapeze frame (anchor included)	ETA-18/0133
	Threaded rod	ETA-18/0131
	Pipe-clamp	ETA-18/0130
	Pipe-clamp saddle nut Pipe-clamp drilled plate	ETA-18/0132 ETA-18/0102

Configuration	System component	ETA number
<p>Single pipe-clamp</p>  	Threaded rod	ETA-18/0131
	Pipe-clamp	ETA-18/0130
	Anchor	See Anchor ETAs
<p>Suspended cantilever</p>  	Threaded rod	ETA-18/0131
	Bracket	ETA-18/0176
	Drilled plate	ETA-18/0102
	Pipe-clamp	ETA-18/0130
	Pipe-clamp saddle nut Pipe-clamp drilled plate	ETA-18/0132 ETA-18/0102
	Anchor	See Anchor ETAs
<p>Non-suspended cantilever</p>  	Threaded rod	ETA-18/0131
	Bracket	ETA-18/0177
	Pipe-clamp	ETA-18/0130
	Pipe-clamp saddle nut Pipe-clamp drilled plate	ETA-18/0132 ETA-18/0102
	Anchor	See Anchor ETAs

Approval body for construction products
and types of construction

Bautechnisches Prüfamt

An institution established by the Federal and
Laender Governments



European Technical Assessment

ETA-17/1067
of 25 January 2018

English translation prepared by DIBt - Original version in German language

General Part

Technical Assessment Body issuing the
European Technical Assessment:

Deutsches Institut für Bautechnik

Trade name of the construction product

Hilti MQ-41/3 headrail and Hilti MQ-41/3 LL headrail

Product family
to which the construction product belongs

Products related to installation systems supporting
technical equipment for building services such as pipes,
conduits, ducts and cables

Manufacturer

Hilti AG
Feldkircherstraße 100
9494 Schaan
FÜRSTENTUM LIECHTENSTEIN

Manufacturing plant

L 1000511
L 1005049
L 1000446

This European Technical Assessment
contains

10 pages including 6 annexes which form an integral part
of this assessment

This European Technical Assessment is
issued in accordance with Regulation (EU)
No 305/2011, on the basis of

EAD 280016-00-0602

The European Technical Assessment is issued by the Technical Assessment Body in its official language. Translations of this European Technical Assessment in other languages shall fully correspond to the original issued document and shall be identified as such.

Communication of this European Technical Assessment, including transmission by electronic means, shall be in full. However, partial reproduction may only be made with the written consent of the issuing Technical Assessment Body. Any partial reproduction shall be identified as such.

This European Technical Assessment may be withdrawn by the issuing Technical Assessment Body, in particular pursuant to information by the Commission in accordance with Article 25(3) of Regulation (EU) No 305/2011.

Specific Part

1 Technical description of the product

Object of this European Technical Assessment are the Hilti MQ-41/3 headrail and the Hilti MQ-41/3 LL headrail. Hilti MQ-41/3 and Hilti MQ-41/3 LL headrails consist of thin metal profiles (channel MQ-41/3 or MQ-41/3 LL), two steel drilled plates MQZ-L11 and one steel saddle nut MQA-M12-B.

The channels are delivered in lengths of 3m (MQ-41/3 3M and MQ-41/3 3M LL) and 6m (MQ-41/3 6M and MQ-41/3 6M LL). The channels are cut to length as required. The center distance of the drilled plates is 200 mm. The distance of the drilled plate center to the nearest channel end is at least 50 mm with the fastener going through a closed long hole of the channel. The distance from the long hole with the fastener to the nearest channel end is at least 18 mm for the channel MQ-41/3 and 11 mm for the channel MQ-41/3 LL.

The saddle nut is positioned centrally between the drilled plates.

Annex A describes the dimensions and the materials of the headrail systems. The requirements for performance assessment are described in Annex B.

2 Specification of the intended use in accordance with the applicable European Assessment Document (EAD)

The performance in chapter 3 can only be assumed if the Hilti MQ-41/3 and Hilti MQ-41/3 LL headrails are used in compliance with the specifications and under the boundary conditions set out in Annexes A to C. The test and assessment methods on which this European Technical Assessment is based lead to an assumption of working life of the Hilti MQ-41/3 und MQ-41/3 LL headrails of at least 50 years in final use under ambient temperatures in indoor areas. The indications given on the working life cannot be interpreted as a guarantee given by the producer, but are to be regarded only as a means for choosing the right products in relation to the expected economically reasonable working life of the works.

3 Performance of the product and references to the methods used for this assessment

3.1 Safety in case of fire (BWR 2)

Essential characteristic	Performance
Reaction to fire	A1

3.2 Safety and accessibility in use (BWR 4)

Essential characteristic	Performance
Dimensions and materials of Hilti MQ-41/3 headrail and Hilti MQ-41/3 LL headrail	see Annex A
Resistance of Hilti MQ-41/3 headrail and Hilti MQ-41/3 LL headrail at elevated temperatures	see Annex C

4 Assessment and verification of constancy of performance (AVCP) system applied, with reference to its legal base

In accordance with the European Assessment Document EAD 280016-00-0602, the following legal bases apply:

- Decision of the commission N° 1996/577/EC:
System 1 applies for the assessment and verification of constancy of performance (AVCP)
- Decision of the commission N° 1999/472/EC:
System 3 applies for the assessment and verification of constancy of performance (AVCP)

5 Technical details necessary for the implementation of the AVCP system, as provided for in the applicable EAD

The technical details necessary for the implementation of the system for the assessment and verification of constancy of performance are laid down in the control plan (confidential part of this European Technical Assessment) deposited at Deutsches Institut für Bautechnik.

Issued in Berlin on 25 January 2018 by Deutsches Institut für Bautechnik

BD Dipl.-Ing. Andreas Kummerow
Head of Department

beglaubigt:
Ortmann

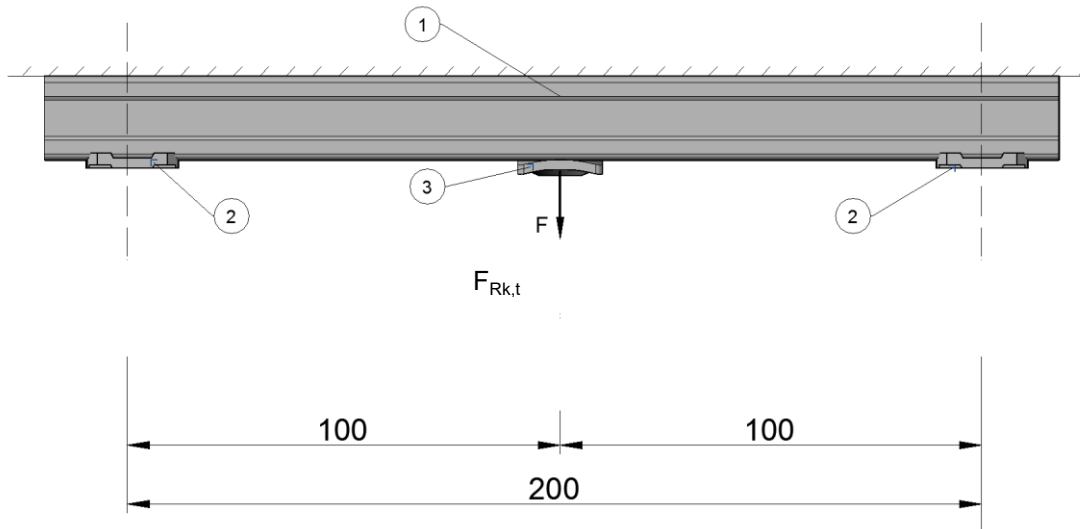

Legend

- 1 MQ-41/3 or MQ-41/3 LL channel
- 2 Drilled plate MQZ-L11
- 3 Saddle nut MQA-M12-B

Annex

- A2
- A2
- A2

Dimensions in mm

Hilti MQ-41/3 headrail and Hilti MQ-41/3 LL headrail

Description of the product (kit)
Dimensions and materials

Annex A1

Tabelle A2.1: Dimensions and materials of the channels

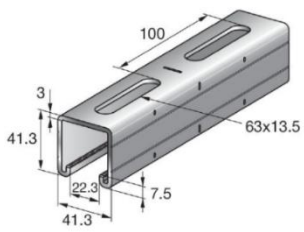
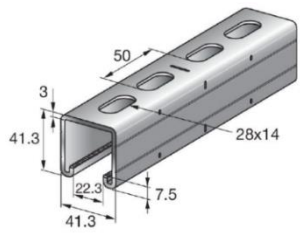
Illustration ¹⁾	Item number	Designation	Length [m]	Material
	369596	MQ-41/3 3M	3	S250GD+Z275-M-A-C according to EN 10346
	369597	MQ-41/3 6M	6	
	2048102	MQ-41/3 3M LL	3	
	2048103	MQ-41/3 6M LL	6	

¹⁾ Dimensions in mm

Table A2.2: Dimensions and materials of the drilled plate

Illustration	Item number	Designation	D [mm]	Material
	2199455	MQZ-L11	11.5	S235JR according to EN 10025-2, zinc coated

Table A2.3: Dimensions and materials of the saddle nut

Illustration	Item number	Designation	M [mm]	Material
	2199453	MQA-M12-B	12	Plate: DD11 according to EN 10111 ²⁾ , zinc coated Nut: C4C according to EN 10263-2, zinc coated Spring section: PET

²⁾ with $235 \text{ N/mm}^2 \leq R_{eL} \leq 340 \text{ N/mm}^2$, Method of deoxidation: fully killed

Hilti MQ-41/3 headrail and Hilti MQ-41/3 LL headrail

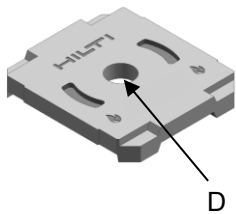
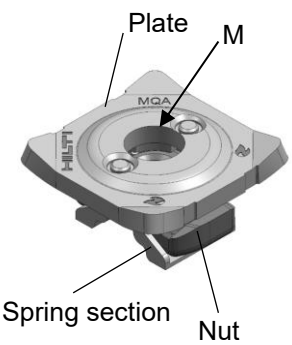
Description of the product (kit)
Dimensions and materials of the components of the kit

Annex A2

English translation prepared by DIBt

- Hilti MQ-41/3 headrail and Hilti MQ-41/3 LL headrail are used to support components of the technical building equipment such as pipes and equipment for sprinkler-, sewage-, drinking-, water-, heating-, cooling-, ventilation-, electrical- and other systems. Hilti MQ-41/3 headrail and Hilti MQ-41/3 LL headrail are performing this load-bearing function at elevated temperatures under the conditions described in this European Technical Assessment in chapter 2.
- The resistance at elevated temperatures applies for static and centric actions on the headrails according to Annex A1. The channel profiles with a length of 300 mm are fastened directly to the reinforced concrete ceiling. On the underside of the ceiling, the channel profile is mounted so that the side with slotted holes rests directly against the ceiling. For this, appropriate anchors at a distance of 200 mm are installed from below through the ceiling and fastened to the open side of the channel profile with drilled plates MQZ-L11. In this type of fixation, the anchor shaft in a length of about 40 mm is exposed to elevated temperatures.
- The resistance at elevated temperatures is referring to the boundary conditions of the standard temperature curve according to EN 1363-1.
- Before installing the channel to the ceiling, it is necessary to ensure by a fire resistance design that the substructure and the fasteners to the substructure are suitable to support the declared resistance of the headrail system.
- The installation of the saddle nut and the threaded rod is carried out according to the following principles:

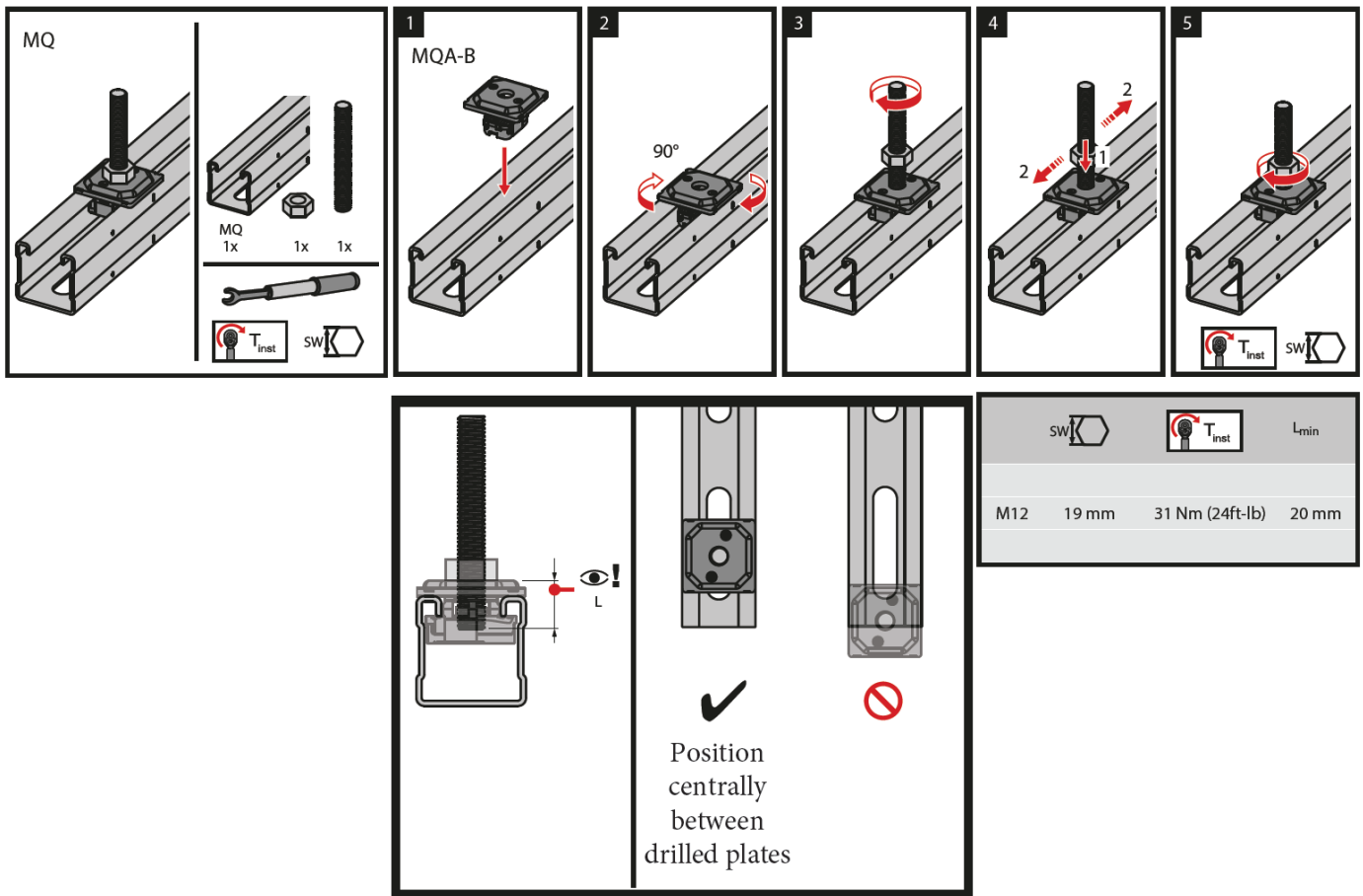

- Installation must be carried out by trained personnel and under the supervision of the site manager.
- The general assembly instructions of the manufacturer in the informative Appendix D must be observed.

Hilti MQ-41/3 headrail and Hilti MQ-41/3 LL headrail

Requirements for performance assessment

Annex B

English translation prepared by DIBt

Table C1: Resistance of Hilti MQ-41/3 headrail and Hilti MQ-41/3 LL headrail with centric load according to Annex A1 at elevated temperatures. Parameters of the regression curve $F_{Rk,t} = c_3(c_1 + c_2/t)$

Span ³⁾ [mm]	c ₁	c ₂	c ₃	t _{min} [minutes]	t _{max} [minutes]
200	706.553	35755.143	0.84663231	21	150

Table C2: Resistance $F_{Rk,t}$ of Hilti MQ-41/3 headrail and Hilti MQ-41/3 LL headrail with centric load according to Annex A1 at elevated temperatures after 30, 60, 90 and 120 minutes

Span ³⁾ [mm]	F _{Rk,30} [N]	F _{Rk,60} [N]	F _{Rk,90} [N]	F _{Rk,120} [N]
200	1607	1103	935	850

³⁾ Distance of the drilled plates (see Annex A1)

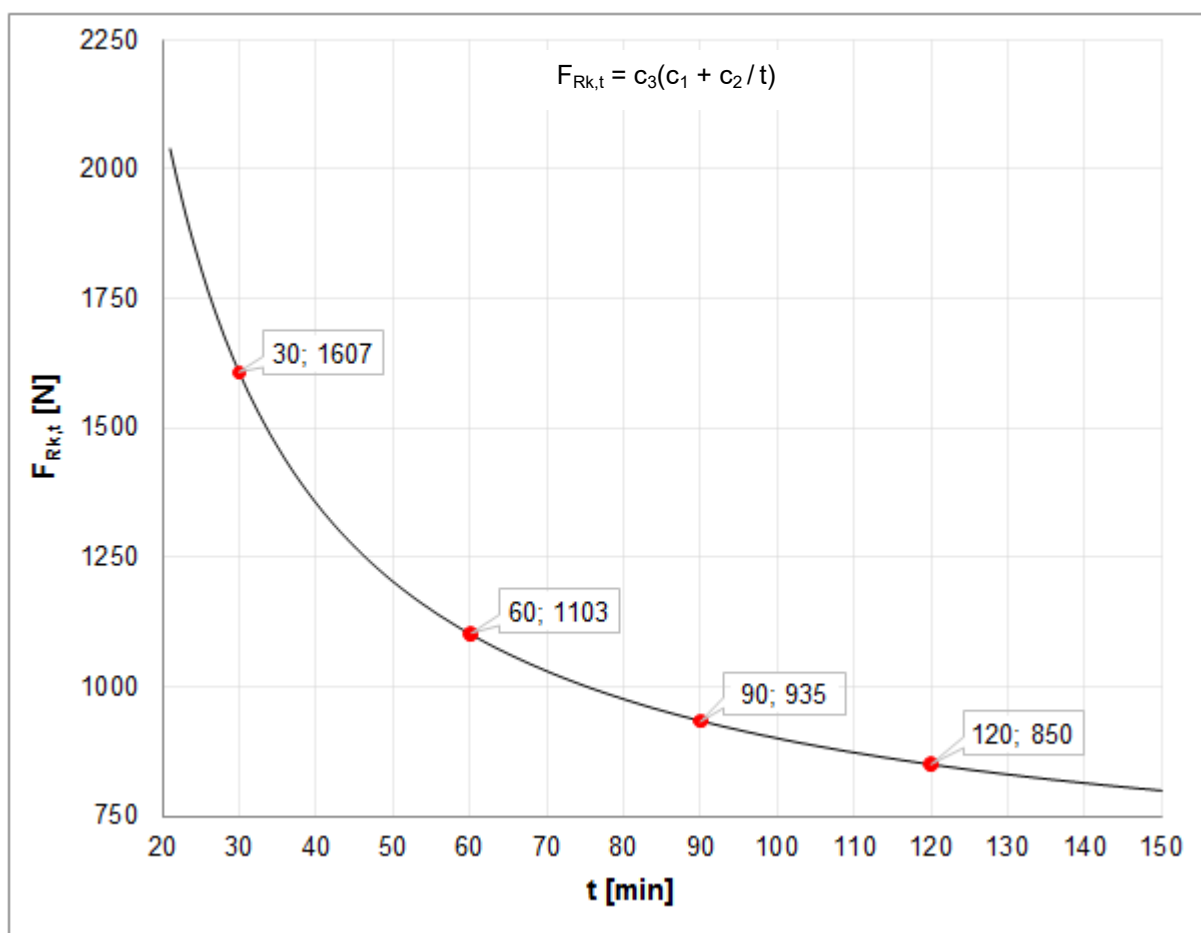
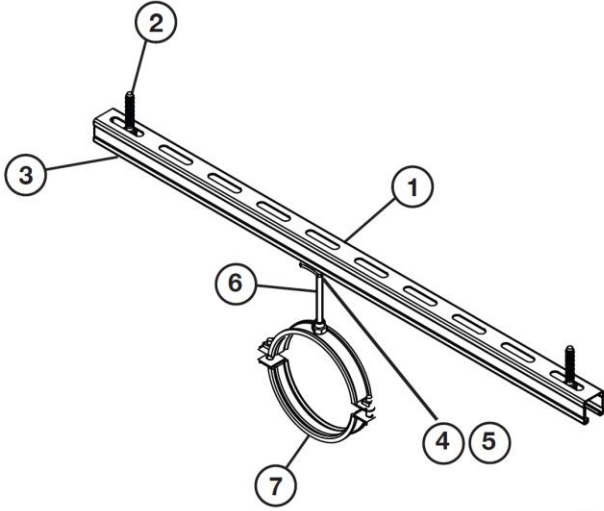

Figure C1: Regression curve according to Table C1

Hilti MQ-41/3 headrail and Hilti MQ-41/3 LL headrail

Resistance at elevated temperatures

Annex C



Bill of material / Stückliste				
Part of typical/ Applikationselement	Ref.	Opt.	Item no. / Artikel Nr.	Description / Bezeichnung
Structure / Aufbau	1		369596	MQ-41/3 3m channel*
	1		2048102	MQ-41/3 LL 3m channel*
	2	A	2105715	HST3 M10x130 70/50 stud anchors
Fixation / Befestigung	2	B	2079798	HUS3 -H 8x100 50/40/30
	3	A	2199455	MQZ-L11 bored plate
Pipe Fixation / Rohrfixierung	4		2199452	MQA-M10-B piping saddle
	5		216466	M10 hexagon nut
	6		339795	AM10x1000 4.8 threaded rod**
	4		2199453	MQA-M12-B piping saddle
	5		216467	M12 hexagon nut
	6		339797	AM12x1000 4.8 threaded rod**
Pipe Ring / Rohrschelle	4		2199454	MQA-M16-B piping saddle
	5		216468	M16 hexagon nut
	6		216422	AM16x1000 4.8 threaded rod**
Pipe Ring / Rohrschelle	M10/ M12/ M16		20843	MP-MI
			20898	(from 3/8" to 244.50", with M10, 12, 16)

* other lengths of the channels also possible / * andere Schienenlängen auch möglich

** Threaded rod available in 1,2 & 3 meters / ** Gewindestange erhältlich in 1,2 & 3 Meter

Assembly Instructions / Montagehinweise

1

Please use the Threaded rod & Anchors either in closed long holes or closed round holes in the channel
Verwendung von Gewindestangen & Dübeln nur durch geschlossene Langlöcher bzw. Rundlöcher der Schiene

3

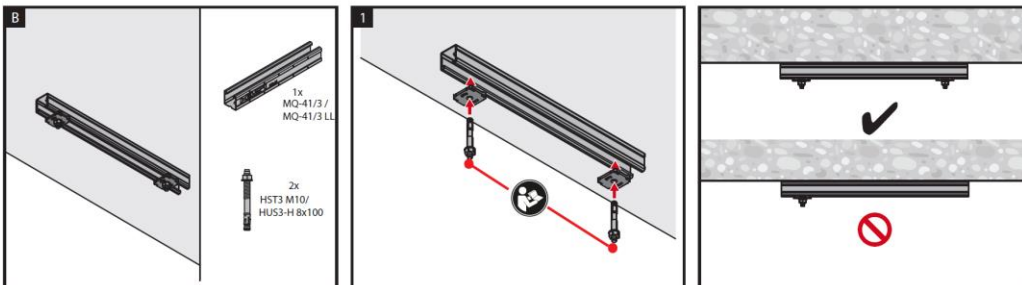

Hilti MQ-41/3 headrail and Hilti MQ-41/3 LL headrail

Assembly instructions

Annex D1
(informative)

4 / 5 / 6

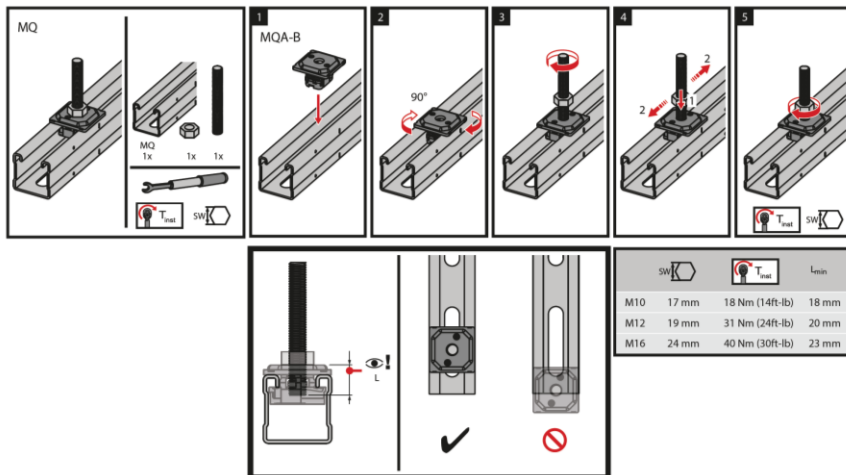

7

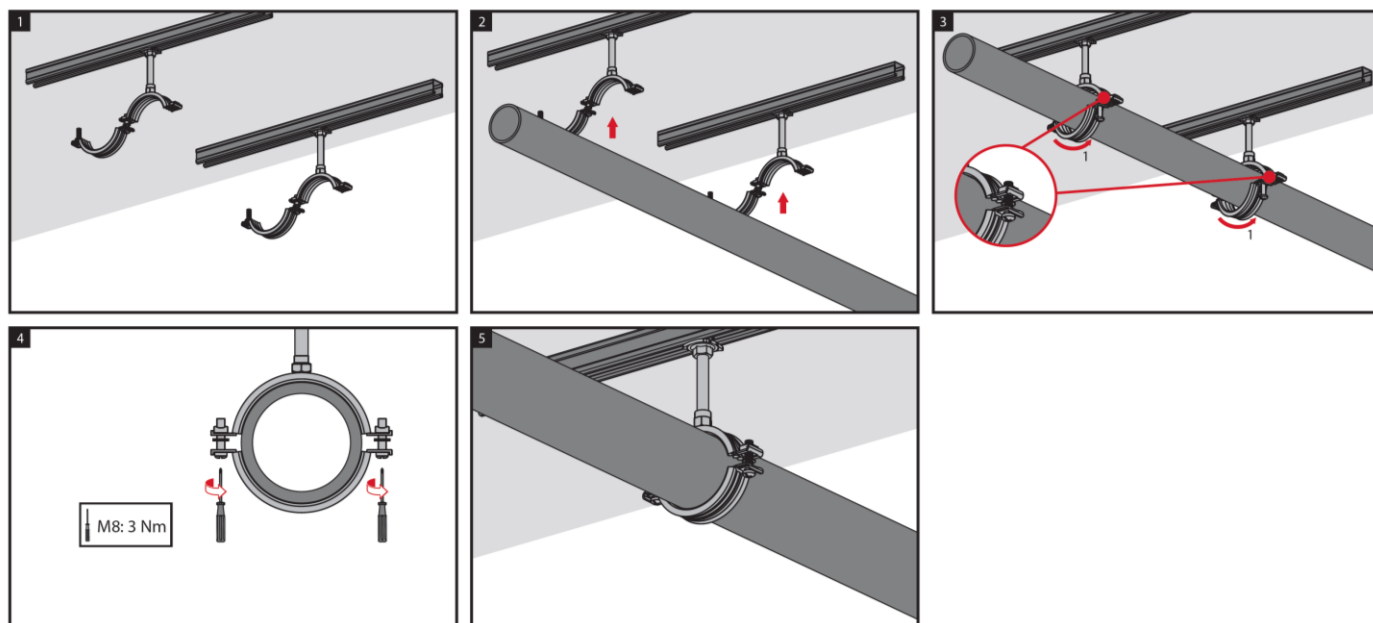

electronic copy of the eta by dibt: eta-17/1067

Hilti MQ-41/3 headrail and Hilti MQ-41/3 LL headrail

Assembly instructions

Annex D2
(informative)

Approval body for construction products
and types of construction

Bautechnisches Prüfamt

An institution established by the Federal and
Laender Governments



European Technical Assessment

ETA-18/0078
of 12 March 2018

English translation prepared by DIBt - Original version in German language

General Part

Technical Assessment Body issuing the
European Technical Assessment:

Deutsches Institut für Bautechnik

Trade name of the construction product

Hilti channel connector MQN-B

Product family
to which the construction product belongs

Products related to installation systems supporting
technical equipment for building services such as pipes,
conduits, ducts and cables

Manufacturer

Hilti AG
Feldkircherstraße 100
9494 Schaan
FÜRSTENTUM LIECHTENSTEIN

Manufacturing plant

L 1000485

This European Technical Assessment
contains

9 pages including 5 annexes which form an integral part
of this assessment

This European Technical Assessment is
issued in accordance with Regulation (EU)
No 305/2011, on the basis of

EAD 280016-00-0602

**European Technical Assessment
ETA-18/0078**

Page 2 of 9 | 12 March 2018

English translation prepared by DIBt

The European Technical Assessment is issued by the Technical Assessment Body in its official language. Translations of this European Technical Assessment in other languages shall fully correspond to the original issued document and shall be identified as such.

Communication of this European Technical Assessment, including transmission by electronic means, shall be in full. However, partial reproduction may only be made with the written consent of the issuing Technical Assessment Body. Any partial reproduction shall be identified as such.

This European Technical Assessment may be withdrawn by the issuing Technical Assessment Body, in particular pursuant to information by the Commission in accordance with Article 25(3) of Regulation (EU) No 305/2011.

Specific part

1 Technical description of the product

Object of this European Technical Assessment is the Hilti channel connector MQN-B. Hilti channel connector MQN-B consists of a nut, a screw, a clamping plate and a spring manufactured from steel. There is a centred round opening on both the clamping plate and the nut, which overlap each other axially with the screw passing through. The screw and nut are connected together and rotate together. Between the nut and the clamping plate is a pre-tensioned spring that lies perpendicular to the baseplate.

The Hilti channel connector MQN-B is used to fasten connectors manufactured from metal such as the Hilti angle connector and Hilti channel supports to Hilti installation channels. In doing so, the Hilti channel connector MQN-B is inserted in the installation opening of the channel and the connecting component, and by pressing on the screw then turning it, it rotates 90° together with the screw. The nut then engages with the retaining projections on the installation channels. By applying force that counteracts the spring force on the screw, the Hilti channel connector MQN-B can be adjusted longitudinally to the installation opening. To finally fasten to the installation channel, the nut is firmly clamped to the retaining projections on the installation channel by tightening the screw.

Annex A describes the dimensions and materials of the Hilti channel connector MQN-B. The requirements for performance assessment are given in Annex B.

2 Specification of the intended use in accordance with the applicable European Assessment Document (EAD)

The performance given in Section 3 can only be assumed if the Hilti channel connector MQN-B is used in compliance with the specifications and under boundary conditions set out in Annexes A to C. The test and assessment methods on which this European Technical Assessment is based lead to an assumption of a working life of the Hilti channel connector MQN-B of at least 50 years in final use under ambient temperatures in indoor areas. The indications given on the working life cannot be interpreted as a guarantee given by the producer, but are to be regarded only as a means for choosing the right products in relation to the expected economically reasonable working life of the works.

In accordance with the European Assessment Document EAD 280016-00-0602, the product is intended to be used in

- a) installations for the support of sprinkler kits;
- b) installations for the support of other building service elements such as pipes, conduits, ducts and cables.

3 Performance of the product and references to the methods used for its assessment

3.1 Safety in case of fire (BWR 2)

Essential characteristic	Performance
Reaction to fire	A1

3.2 Safety and accessibility in use (BWR 4)

Essential characteristic	Performance
Dimensions and materials of Hilti channel connector MQN-B	see Annex A
Resistance of Hilti channel connector MQN-B at ambient temperature	see Annex C

4 Assessment and verification of constancy of performance (AVCP) system applied, with reference to its legal base

In accordance with the European Assessment Document EAD 280016-00-0602, the following legal bases apply:

- In case of intended use a) specified in Section 2:
Decision of the commission N° 1996/577/EC:
System 1 applies for the assessment and verification of constancy of performance (AVCP).
- In case of intended use b) specified in Section 2:
Decision of the commission N° 1999/472/EC:
System 3 applies for the assessment and verification of constancy of performance (AVCP).

5 Technical details necessary for the implementation of the AVCP system, as provided for in the applicable EAD

The technical details necessary for the implementation of the system for the assessment and verification of constancy of performance are laid down in the control plan (confidential part of this European Technical Assessment) deposited at Deutsches Institut für Bautechnik.

Issued in Berlin on 12 March 2018 by Deutsches Institut für Bautechnik

BD Dipl.-Ing. Andreas Kummerow
Head of Department

beglaubigt:
Häßler

English translation prepared by DIBt

Table A1: Materials of the components of the Hilti channel connector MQN-B

Illustration	Item number	Designation	Material
	2184853	MQN-B	<p>Plate: DD11 in accordance with EN 10111¹⁾, zinc coated</p> <p>Nut: S355MC in accordance with EN 10149-2, zinc coated</p> <p>Screw: strength class 8.8 in accordance with EN ISO 898-1, zinc coated</p> <p>Spring element: X10CrNi18-8 in accordance with EN 10270-3</p>

¹⁾ with $235 \text{ N/mm}^2 \leq R_{eL} \leq 340 \text{ N/mm}^2$, Method of deoxidation: fully killed

Table A2: Dimensions²⁾ of the components of the Hilti channel connector MQN-B

Plate	Nut	Screw	Spring element

²⁾ Dimensions in mm

Hilti channel connector MQN-B	Annex A
Product description Dimensions and materials	

- The Hilti channel connector MQN-B is used to transfer the loads of building services components such as ducts and equipment for sprinkler, water, heating, cooling, ventilation, electrical and other installations. The Hilti channel connector MQN-B is suitable for undertaking this load-bearing function under the conditions described in Section 2 of this European Technical Assessment.
- The Hilti channel connector MQN-B is used to fasten connectors manufactured from metal such as the Hilti angle connector and Hilti channel supports to Hilti installation channels. The nut and the plate on the channel connector are firmly connected to the installation channel and the attached component by tightening the screw.
- The performance of the Hilti channel connector MQN-B results in connection with Hilti installation channels as per Table B2. The channels are cut to length centrally between the longholes or the roundholes at the marking. The cut channel is within a range of 2 mm from both sides of the marking.
- The installation instructions according to Figure B1.1 are a prerequisite for the information on the performance assessment in Annex C.
- The longitudinal axes of the MQN-B nut and the channel are perpendicular to each other after assembly with centric position of the screw between the parallel flanges of the channel.
- Information on resistance at ambient temperature applies to static and centric actions.
- The centric distance of the MQN-B nut from the channel end is 29 mm to assess the pull-out resistance of the channel connector given by the geometry of the adapter for load introduction.
- The adjacent component to the channel to assess the shear resistance of the channel connector is made of the steel type S235JR in accordance with EN 10025 with 4 mm thickness and with the opening geometry to pass through the nut of the channel connector according to Figure B1.2.

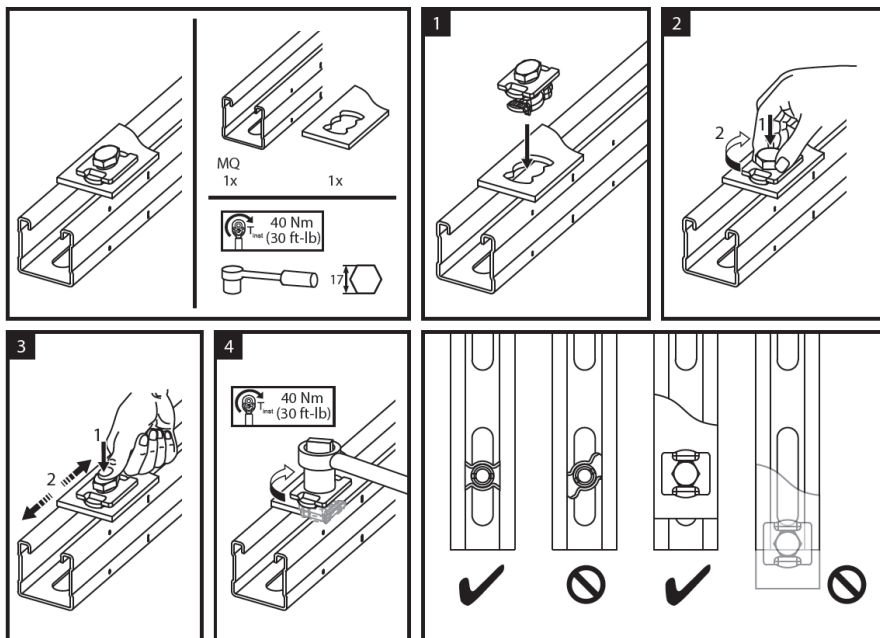

Figure B1.1: Installation instructions

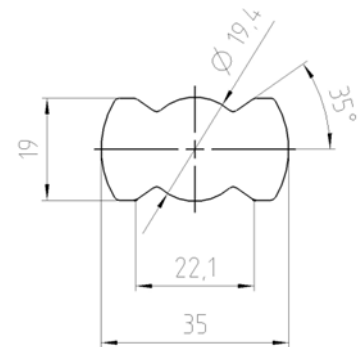

Figure B1.2:
Opening geometry to pass through the nut of the channel connector (dimensions in mm)

electronic copy of the eta by dibt: eta-18/0078

Hilti channel connector MQN-B	Annex B1
Requirements for performance assessment	

Table B2: Dimensions and materials of installation channels for use with Hilti channel connector MQN-B

Illustration ³⁾	Item number	Designation	Length [m]	Material and coating
	369596	MQ-41/3 3M	3	S250GD+Z275-M-A-C in accordance with EN 10346
	369597	MQ-41/3 6M	6	
	2048102	MQ-41/3 3M LL	3	S250GD+Z275-M-A-C in accordance with EN 10346
	2048103	MQ-41/3 6M LL	6	
	369603	MQ-41 D 3m	3	S250GD+Z275-M-A-C in accordance with EN 10346
	369604	MQ-41 D 6m	6	
	369592	MQ-41 6m	6	S250GD+Z275-M-A-C in accordance with EN 10346
	369591	MQ-41 3m	3	
	304559	MQ-41 2m	2	

³⁾ Dimensions in mm

Hilti channel connector MQN-B

Requirements for performance assessment

Annex B2

Table B3: Cross-section properties of installation channels for use with Hilti channel connector MQN-B

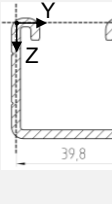
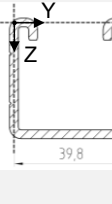
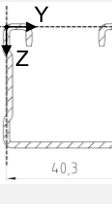
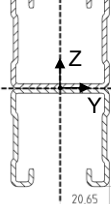
Description	Symbol	MQ-41/3	MQ-41/3 LL	MQ-41	MQ-41 D	Unit
						
Classification cross section in accordance with EN 1993-1-1	-	3	3	3	3	-
Cross section areas	A	375.88	379.93	263.62	545.97	mm ²
	A _{tot}	375.88	379.93	263.62	545.97	mm ²
Shear areas	A _y	48.69	54.43	27.23	66.37	mm ²
	A _z	195.47	194.59	131.51	197.58	mm ²
Centroid position	y _{C,0}	19.15	19.15	19.65	0.00	mm
	z _{C,0}	20.57	20.76	20.52	0.00	mm
Moments of inertia	I _y	76963.50	78224.80	57501.00	323585.00	mm ⁴
	I _z	107949.00	108011.00	76416.00	154070.00	mm ⁴
Inclination of principal axes	α	90.00	90.00	90.00	0.00	°
Polar moments of inertia	I _p	184913.00	186236.00	133917.00	477656.00	mm ⁴
	I _{p,M}	778900.00	780561.00	601859.00	477656.00	mm ⁴
Radii of gyration	i _y	14.31	14.35	14.77	24.35	mm
	i _z	16.95	16.86	17.03	16.80	mm
Polar radii of gyration	i _p	22.18	22.14	22.54	29.58	mm
	i _{p,M}	45.52	45.33	47.78	29.58	mm
Warping radius of gyration	i _{w,M}	7.02	7.02	7.19	17.32	mm
Torsional constant	J	848.88	856.29	269.75	575.03	mm ⁴
Secondary torsional constant	J _s	105319.00	105394.00	74075.40	91246.30	mm ⁴
Location of the shear center	y _{M,0}	19.15	19.15	19.65	0.00	mm
	z _{M,0}	60.32	60.31	62.63	0.00	mm
	y _M	0.00	0.00	0.00	0.00	mm
	z _M	39.75	39.55	42.11	0.00	mm
Warping constants	I _{w,C}	2.09277E+08	2.07678E+08	1.66135E+08	1.43225E+08	mm ⁶
	I _{w,M}	38387600	38417600.00	31116700.00	1.43225E+08	mm ⁶
	r _{w,M}	0.00	0.00	0.00	0.00	-
Section moduli	S _{y,max}	4002.48	4108.45	2906.72	7834.29	mm ³
	S _{y,min}	-3487.10	-3514.15	-2672.22	-7833.74	mm ³
	S _{z,max}	5227.58	5230.56	3700.53	7460.71	mm ³
	S _{z,min}	-5277.58	-5230.56	-3700.54	-7460.71	mm ³
Torsional section modulus	S _t	282.96	285.43	134.88	287.51	mm ³
Max. plastic bending moment	M _{pl,y,k}	NPA ⁴⁾	NPA	NPA	NPA	kNm
	M _{pl,z,k}	NPA	NPA	NPA	NPA	kNm
Max. plastic section moduli	Z _y	NPA	NPA	NPA	NPA	mm ³
	Z _z	NPA	NPA	NPA	NPA	mm ³
Plastic shear areas	A _{pl,y}	NPA	NPA	NPA	NPA	mm ²
	A _{pl,z}	NPA	NPA	NPA	NPA	mm ²
Area bisecting axis position	f _{y,0}	NPA	NPA	NPA	NPA	mm
	f _{z,0}	NPA	NPA	NPA	NPA	mm
Plastic shear forces	V _{pl,y,k}	NPA	NPA	NPA	NPA	kN
	V _{pl,z,k}	NPA	NPA	NPA	NPA	kN
Plastic axial force	N _{pl,k}	NPA	NPA	NPA	NPA	kN
Buckling curves	BC _y	c	c	c	c	-
	BC _z	c	c	c	c	-

⁴⁾ NPA: no performance assessed

Hilti channel connector MQN-B

Requirements for performance assessment

Annex B3

Table C1: Characteristic pull-out resistance at ambient temperature

Channel connector	Installation channel	Characteristic pull-out resistance	Partial safety coefficient ⁵⁾
		$F_{Rk,y}$ [kN]	γ_M
MQN-B	MQ-41/3	16.33	1.25
	MQ-41/3 LL		
	MQ-41	12.46	1.78
	MQ-41 D		

Table C2: Characteristic shear resistance at ambient temperature

Channel connector	Installation channel	Characteristic shear resistance	Partial safety coefficient ⁵⁾
		$F_{Rk,x}$ [kN]	γ_M
MQN-B	MQ-41/3	10.42	1.25
	MQ-41/3 LL		
	MQ-41	10.72	1.53
	MQ-41 D		

⁵⁾ provided that no other national regulations apply

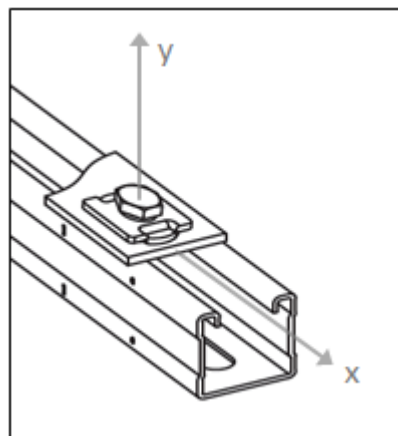

Figure C1: Coordinate system for the pull-out and shear resistance

Hilti channel connector MQN-B

Resistance at ambient temperature

Annex C

Approval body for construction products
and types of construction

Bautechnisches Prüfamt

An institution established by the Federal and
Laender Governments



European Technical Assessment

ETA-18/0102
of 13 April 2018

English translation prepared by DIBt - Original version in German language

General Part

Technical Assessment Body issuing the
European Technical Assessment:

Deutsches Institut für Bautechnik

Trade name of the construction product

Hilti drilled plate MQZ-L11 and Hilti drilled plate MQZ-L13

Product family
to which the construction product belongs

Products related to installation systems supporting
technical equipment for building services such as pipes,
conduits, ducts and cables

Manufacturer

Hilti AG
Feldkircherstraße 100
9494 Schaan
FÜRSTENTUM LIECHTENSTEIN

Manufacturing plant

L 1000446
L 1005049

This European Technical Assessment
contains

12 pages including 8 annexes which form an integral part
of this assessment

This European Technical Assessment is
issued in accordance with Regulation (EU)
No 305/2011, on the basis of

EAD 280016-00-0602

The European Technical Assessment is issued by the Technical Assessment Body in its official language. Translations of this European Technical Assessment in other languages shall fully correspond to the original issued document and shall be identified as such.

Communication of this European Technical Assessment, including transmission by electronic means, shall be in full. However, partial reproduction may only be made with the written consent of the issuing Technical Assessment Body. Any partial reproduction shall be identified as such.

This European Technical Assessment may be withdrawn by the issuing Technical Assessment Body, in particular pursuant to information by the Commission in accordance with Article 25(3) of Regulation (EU) No 305/2011.

Specific part

1 Technical description of the product

Objects of this European Technical Assessment are the Hilti drilled plate MQZ-L11 and Hilti drilled plate MQZ-L13. The Hilti MQZ-L11 and MQZ-L13 drilled plates are steel plates that are stamped rectangularly with a centrally positioned opening, which is 11.5 mm or 13.5 mm in diameter. The plates have raised edges in the corners at the rear to ensure a perfect fit with the Hilti installation channels.

Annex A describes the dimensions and materials of the Hilti MQZ-L11 and MQZ-L13 drilled plates. The requirements for performance assessment are given in Annex B.

2 Specification of the intended use in accordance with the applicable European Assessment Document (EAD)

The performance given in Section 3 can only be assumed if the Hilti MQZ-L11 and MQZ-L13 drilled plates are used in compliance with the specifications and under boundary conditions set out in Annexes A to D. The test and assessment methods on which this European Technical Assessment is based lead to an assumption of a working life of the Hilti MQZ-L11 and MQZ-L13 drilled plates of at least 50 years in final use under ambient temperatures in indoor areas. The indications given on the working life cannot be interpreted as a guarantee given by the producer, but are to be regarded only as a means for choosing the right products in relation to the expected economically reasonable working life of the works.

In accordance with the European Assessment Document EAD 280016-00-0602, the product is intended to be used in

- a) installations for the support of sprinkler kits;
- b) installations for the support of other building service elements such as pipes, conduits, ducts and cables.

3 Performance of the product and references to the methods used for its assessment

3.1 Safety in case of fire (BWR 2)

Essential characteristic	Performance
Reaction to fire	Class A1

3.2 Safety and accessibility in use (BWR 4)

Essential characteristic	Performance
Dimensions and materials of Hilti MQZ-L11 and MQZ-L13 drilled plates	see Annex A
Resistance of Hilti MQZ-L11 and MQZ-L13 drilled plates at ambient temperature	see Annex C
Resistance of Hilti MQZ-L11 and MQZ-L13 drilled plates at elevated temperature	see Annex D

English translation prepared by DIBt

4 Assessment and verification of constancy of performance (AVCP) system applied, with reference to its legal base

In accordance with the European Assessment Document EAD 280016-00-0602, the following legal bases apply:

- In case of intended use a) specified in Section 2:
Decision of the commission N° 1996/577/EC:
System 1 applies for the assessment and verification of constancy of performance (AVCP).
- In case of intended use b) specified in Section 2:
Decision of the commission N° 1999/472/EC:
System 3 applies for the assessment and verification of constancy of performance (AVCP).

5 Technical details necessary for the implementation of the AVCP system, as provided for in the applicable EAD



The technical details necessary for the implementation of the system for the assessment and verification of constancy of performance are laid down in the control plan (confidential part of this European Technical Assessment) deposited at Deutsches Institut für Bautechnik.

Issued in Berlin on 13 April 2018 by Deutsches Institut für Bautechnik

BD Dipl.-Ing. Andreas Kummerow
Head of Department

beglaubigt:
Ortmann

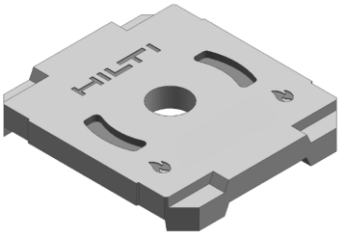
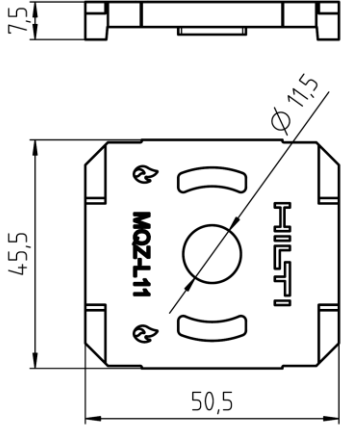
Table A1: Dimensions and materials of drilled plates

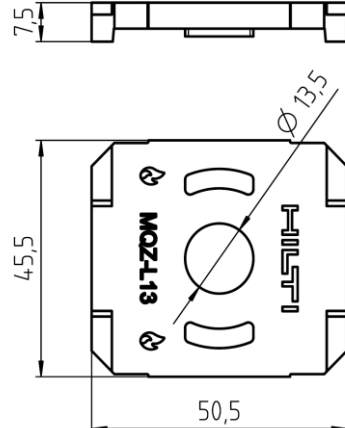
Illustration	Dimension [mm]	Designation	Item number	Materials
		MQZ-L11	2199455	S235JR in accordance with EN 10025-2, zinc coated
		MQZ-L13	2199456	S235JR in accordance with EN 10025-2, zinc coated

Hilti drilled plate MQZ-L11 and Hilti drilled plate MQZ-L13

Product description
Dimensions and materials

Annex A

English translation prepared by DIBt

- MQZ-L11 and MQZ-L13 drilled plates are used in building service installation systems at ambient and elevated temperatures. MQZ-L11 and MQZ-L13 drilled plates are used to transfer building services component loads such as ducts and equipment for sprinklers, water, heating, cooling, ventilation, electrical and other installations. MQZ-L11 and MQZ-L13 drilled plates described in this ETA are suitable for undertaking this load-bearing function under the conditions listed in Section 2.
- MQZ-L11 and MQZ-L13 drilled plates are used to fix threaded rods to installation channels or brackets in conjunction with hexagonal nuts.
- The following information is a prerequisite for the information on the performance assessment in Annex C and Annex D:
 - The performance of MQZ-L11 results in connection with zinc coated threaded rods in accordance with EN ISO 898-1 in strength class 4.8 as per Table B2.1, zinc coated hexagonal nuts in accordance with EN ISO 898-2 in strength class 8 as per Table B2.3 and Hilti installation channels according to Annex B3 to B5.
 - The performance of MQZ-L13 results in connection with zinc coated threaded rods in accordance with EN ISO 898-1 in strength class 4.8 as per Table B2.2, zinc coated hexagonal nuts in accordance with EN ISO 898-2 in strength class 8 as per Table B2.4 and Hilti installation channels according to Annex B3 to B5.
 - The resistance at ambient and elevated temperatures applies for static and centric actions according to the following set up:

The centre distance of the MQZ-L11 or MQZ-L13 drilled plates from the channel end is 25 mm. The centre distance of the suspension points with the drilled plates is 250 mm. The load is applied centrally between the suspension points.

- The resistance and deformation at elevated temperatures is referring to the boundary conditions of the standard temperature time curve in accordance with EN 1363-1.
- Installation instructions:

The installation channels are cut to length centrally between the longholes or the roundholes at the marking. The cut channel lies within a range of 2 mm from both sides of the marking.

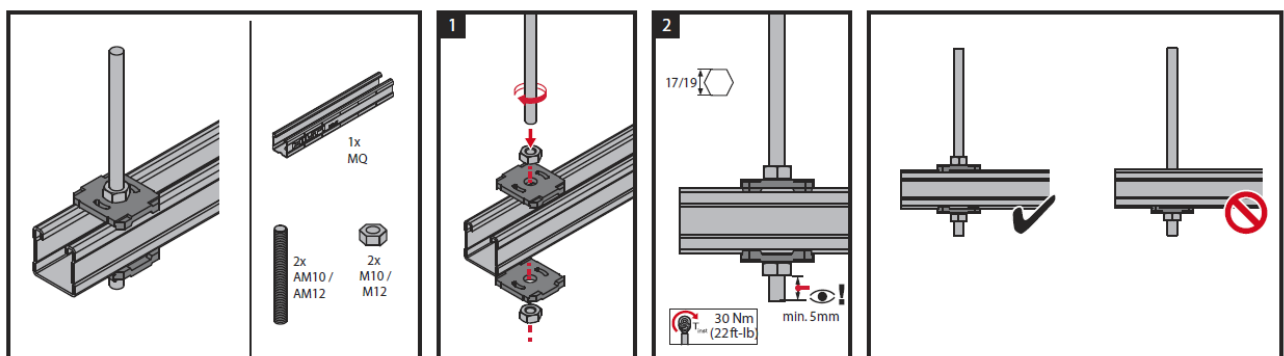

Hilti drilled plate MQZ-L11 and Hilti drilled plate MQZ-L13

Requirements for performance assessment

Annex B1

Table B2.1: Threaded rods for use with MQZ-L11

Illustration	Designation	Item number	M thread	L [mm]	Materials and coatings
	AM10x3000 4.8	216418	M10	3000	Strength class 4.8 in accordance with DIN 976-1, zinc coated
	AM10x2000 4.8	339796	M10	2000	
	AM10x1000 4.8	339795	M10	1000	

Table B2.2: Threaded rods for use with MQZ-L13

Illustration	Designation	Item number	M thread	L [mm]	Materials and coatings
	AM12x3000 4.8	216421	M12	3000	Strength class 4.8 in accordance with DIN 976-1, zinc coated
	AM12x2000 4.8	216420	M12	2000	
	AM12x1000 4.8	339797	M12	1000	

Table B2.3: Hexagonal nuts for use with MQZ-L11

Illustration	Designation	Item number	M thread	W [mm]	H [mm]	Materials and coatings
	M10 hexagonal nut	216466	M10	17	8	Strength class 8 in accordance with ISO 4032, zinc coated

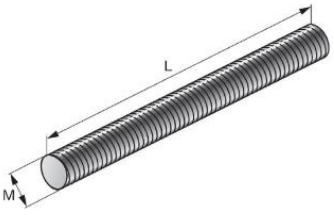
Table B2.4: Hexagonal nuts for use with MQZ-L13

Illustration	Designation	Item number	M thread	W [mm]	H [mm]	Materials and coatings
	M12 hexagonal nut	216467	M12	19	10	Strength class 8 in accordance with ISO 4032, zinc coated

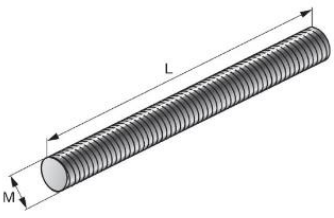
Hilti drilled plate MQZ-L11 and Hilti drilled plate MQZ-L13

Requirements for performance assessment

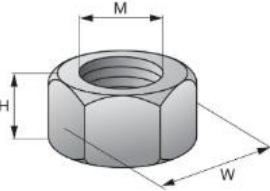
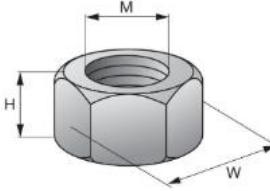
Annex B2

Table B3: Dimensions and materials of installation channels for use with Hilti drilled plates

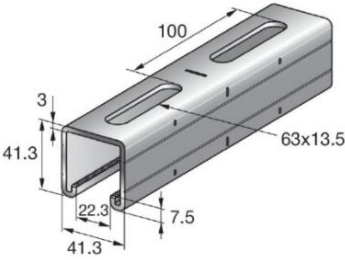
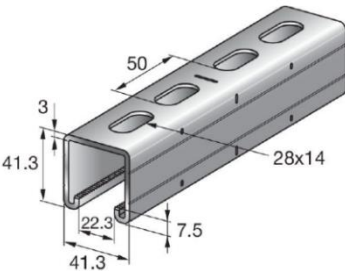
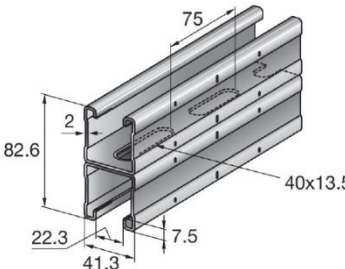
Illustration ¹⁾	Item number	Designation	Length [m]	Materials and coatings
	369596	MQ-41/3 3M	3	S250GD+Z275-M-A-C in accordance with EN 10346
	369597	MQ-41/3 6M	6	
	2048102	MQ-41/3 3M LL	3	S250GD+Z275-M-A-C in accordance with EN 10346
	2048103	MQ-41/3 6M LL	6	
	369603	MQ-41 D 3m	3	S250GD+Z275-M-A-C in accordance with EN 10346
	369604	MQ-41 D 6m	6	

¹⁾ Dimensions in mm

Hilti drilled plate MQZ-L11 and Hilti drilled plate MQZ-L13

Requirements for performance assessment

Annex B3

Table B4: Dimensions and materials of installation channels for use with Hilti drilled plates

Illustration ²⁾	Item number	Designation	Length [m]	Materials and coatings
	2184773	MQ-21.5 6m	6	S280GD+Z140-M-A-C in accordance with EN 10346
	2184772	MQ-21.5 3m	3	
	2184771	MQ-21.5 2m	2	
	369592	MQ-41 6m	6	S250GD+Z275-M-A-C in accordance with EN 10346
	369591	MQ-41 3m	3	
	304559	MQ-41 2m	2	
	2141964	MQ-41-L 6m	6	S250GD+Z140-M-A-C in accordance with EN 10346
	2141965	MQ-41-L 3m	3	
	2141966	MQ-41-L 2m	2	

²⁾ Dimensions in mm

Hilti drilled plate MQZ-L11 and Hilti drilled plate MQZ-L13

Requirements for performance assessment

Annex B4

Table B5: Section properties of installation channels for use with Hilti drilled plates

Description	Symbol	MQ-41/3	MQ-41/3 LL	MQ-41 D	MQ-21.5	MQ-41	MQ-41-L	Unit
Classification cross section in accordance with EN 1993-1-1	-	3	3	3	3	3	3	-
Cross section areas	A	375.88	379.93	545.97	142.71	263.62	199.57	mm ²
	A _{tot}	375.88	379.93	545.97	142.71	263.62	199.57	mm ²
Shear areas	A _y	48.69	54.43	66.37	23.47	27.23	20.24	mm ²
	A _z	195.47	194.59	197.58	41.86	131.51	98.37	mm ²
Centroid position	y _{C,0}	19.15	19.15	0.00	0.00	19.65	0.00	mm
	z _{C,0}	20.57	20.76	0.00	-9.12	20.52	-19.91	mm
Moments of inertia	I _y	76963.50	78224.80	323585.00	9168.75	57501.00	44773.00	mm ⁴
	I _z	107949.00	108011.00	154070.00	37416.40	76416.00	58981.50	mm ⁴
Inclination of principal axes	α	90.00	90.00	0.00	90.00	90.00	90.00	°
Polar moments of inertia	I _p	184913.00	186236.00	477656.00	46585.10	133917.00	103754.00	mm ⁴
	I _{p,M}	778900.00	780561.00	477656.00	115093.00	601859.00	469974.00	mm ⁴
Radii of gyration	i _y	14.31	14.35	24.35	8.02	14.77	14.98	mm
	i _z	16.95	16.86	16.80	16.19	17.03	17.19	mm
Polar radii of gyration	i _p	22.18	22.14	29.58	18.07	22.54	22.80	mm
	i _{p,M}	45.52	45.33	29.58	28.40	47.78	48.53	mm
Warping radius of gyration	i _{ω,M}	7.02	7.02	17.32	6.85	7.19	7.44	mm
Torsional constant	J	848.88	856.29	575.03	76.58	269.75	112.13	mm ⁴
Secondary torsional constant	J _s	105319.00	105394.00	91246.30	25157.50	74075.40	565590.00	mm ⁴
Location of the shear center	y _{M,0}	19.15	19.15	0.00	0.00	19.65	0.00	mm
	z _{M,0}	60.32	60.31	0.00	12.77	62.63	22.92	mm
	y _M	0.00	0.00	0.00	0.00	0.00	0.00	mm
	z _M	39.75	39.55	0.00	21.90	42.11	42.84	mm
Warping constants	I _{ω,C}	2.09277E+08	2.07678E+08	1.43225E+08	23255400.00	1.66135E+08	1.34296E+08	mm ⁶
	I _{ω,M}	38387600	38417600.00	1.43225E+08	5395050.00	31116700.00	26017600	mm ⁶
	Γ _{ω,M}	0.00	0.00	0.00	0.00	0.00	0.00	-
Section moduli	S _{y,max}	4002.48	4108.45	7834.29	928.54	2906.72	2248.07	mm ³
	S _{y,min}	-3487.10	-3514.15	-7833.74	-788.66	-2672.22	-2093.62	mm ³
	S _{z,max}	5227.58	5230.56	7460.71	1811.93	3700.53	2856.29	mm ³
	S _{z,min}	-5277.58	-5230.56	-7460.71	-1811.93	-3700.54	-2856.25	mm ³
Torsional section modulus	S _t	282.96	285.43	287.51	51.06	134.88	75.76	mm ³
Max. plastic bending moment	M _{pl,y,d}	NPA ³⁾	NPA	NPA	NPA	NPA	NPA	kNm
	M _{pl,z,d}	NPA	NPA	NPA	NPA	NPA	NPA	kNm
Max. plastic section moduli	Z _y	NPA	NPA	NPA	NPA	NPA	NPA	mm ³
	Z _z	NPA	NPA	NPA	NPA	NPA	NPA	mm ³
Plastic shear areas	A _{pl,y}	NPA	NPA	NPA	NPA	NPA	NPA	mm ²
	A _{pl,z}	NPA	NPA	NPA	NPA	NPA	NPA	mm ²
Area bisecting axis position	f _{y,0}	NPA	NPA	NPA	NPA	NPA	NPA	mm
	f _{z,0}	NPA	NPA	NPA	NPA	NPA	NPA	mm
Plastic shear forces	V _{pl,y,d}	NPA	NPA	NPA	NPA	NPA	NPA	kN
	V _{pl,z,d}	NPA	NPA	NPA	NPA	NPA	NPA	kN
Plastic axial force	N _{pl,d}	NPA	NPA	NPA	NPA	NPA	NPA	kN
Buckling curves	BC _y	c	c	c	c	c	c	-
	BC _z	c	c	c	c	c	c	-

³⁾ NPA: No performance assessed

Hilti drilled plate MQZ-L11 and Hilti drilled plate MQZ-L13

Requirements for performance assessment

Annex B5

Table C1: Direction of force and arrangement of the drilled plates

Illustration	Installation channel
	<p>MQ-41/3 MQ-41/3 LL MQ-41 MQ-41-L MQ-21.5</p>
	<p>MQ-41 D</p>

Table C2: Characteristics at ambient temperature

Drilled plates	Installation channel	Characteristic pull-out resistance	Partial safety coefficient ⁴⁾
		F_{Rk} [kN]	γ_M
MQZ-L11 MQZ-L13	MQ-41/3	25.00	1.99
	MQ-41/3 LL		
	MQ-41	18.40	1.75
	MQ-41 D		
	MQ-41-L	11.70	1.40
	MQ-21.5	16.10	1.93

⁴⁾ provided that no other national regulations apply

Hilti drilled plate MQZ-L11 and Hilti drilled plate MQZ-L13

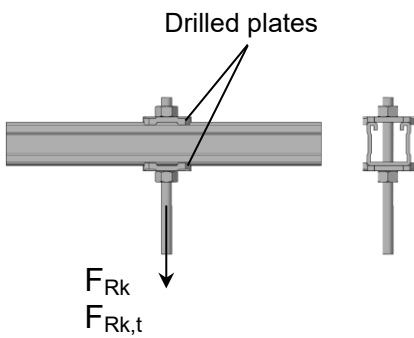
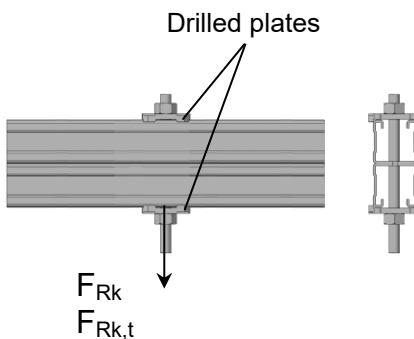
Direction of force and arrangement of the drilled plates
Characteristics at ambient temperature

Annex C

Table D1: Pull-out resistance at elevated temperatures (2 suspension points)
Parameter of regression curve $2 \cdot F_{Rk}(t) = c_3 (c_1 + c_2 / t)$

Drilled plates	Installation channel	c_1	c_2	c_3	t_{min} [Minutes]	t_{max} [Minutes]
MQZ-L11 MQZ-L13	MQ-41/3	963.500	76594.354	0.847958	25	150
	MQ-41/3 LL					
	MQ-41	NPA ⁵⁾	NPA	NPA	NPA	NPA
	MQ-41 D					
	MQ-41-L	NPA	NPA	NPA	NPA	NPA
	MQ-21.5	NPA	NPA	NPA	NPA	NPA

Table D2: Pull-out resistance $F_{Rk,t}$ at elevated temperatures⁶⁾ of the single drilled plate

Drilled plates	Installation channel	$F_{Rk,30}$ [N]	$F_{Rk,60}$ [N]	$F_{Rk,90}$ [N]	$F_{Rk,120}$ [N]
MQZ-L11 MQZ-L13	MQ-41/3	1491	949	769	679
	MQ-41/3 LL				
	MQ-41	NPA	NPA	NPA	NPA
	MQ-41 D				
	MQ-41-L	NPA	NPA	NPA	NPA
	MQ-21.5	NPA	NPA	NPA	NPA

⁵⁾ NPA: No performance assessed

⁶⁾ Direction of force and arrangement of the drilled plates see Table C1

Hilti drilled plate MQZ-L11 and Hilti drilled plate MQZ-L13

Pull-out resistance at elevated temperatures

Annex D

Approval body for construction products
and types of construction

Bautechnisches Prüfamt

An institution established by the Federal and
Laender Governments



European Technical Assessment

ETA-18/0119
of 26 June 2018

English translation prepared by DIBt - Original version in German language

General Part

Technical Assessment Body issuing the
European Technical Assessment:

Deutsches Institut für Bautechnik

Trade name of the construction product

Hilti installation channel MQ-41/3,
Hilti installation channel MQ-41/3 LL,
Hilti installation channel MQ-41 D,
Hilti installation channel MQ-21.5,
Hilti installation channel MQ-41 and
Hilti installation channel MQ-41-L

Product family
to which the construction product belongs

Products related to installation systems supporting
technical equipment for building services such as pipes,
conduits, ducts and cables

Manufacturer

Hilti AG
Feldkircherstraße 100
9494 Schaan
FÜRSTENTUM LIECHTENSTEIN

Manufacturing plant

L1000511

This European Technical Assessment
contains

46 pages including 42 annexes which form an integral
part of this assessment

This European Technical Assessment is
issued in accordance with Regulation (EU)
No 305/2011, on the basis of

EAD 280016-00-0602

The European Technical Assessment is issued by the Technical Assessment Body in its official language. Translations of this European Technical Assessment in other languages shall fully correspond to the original issued document and shall be identified as such.

Communication of this European Technical Assessment, including transmission by electronic means, shall be in full. However, partial reproduction may only be made with the written consent of the issuing Technical Assessment Body. Any partial reproduction shall be identified as such.

This European Technical Assessment may be withdrawn by the issuing Technical Assessment Body, in particular pursuant to information by the Commission in accordance with Article 25(3) of Regulation (EU) No 305/2011.

Specific Part

1 Technical description of the product

Objects of this European Technical Assessment are Hilti installation channels MQ-41/3, MQ-41/3 LL, MQ-41 D, MQ-21.5, MQ-41 and MQ-41-L. The Hilti installation channels MQ-41/3, MQ-41/3 LL, MQ-41, MQ-41-L and MQ-21.5 consist of thin-walled steel with parallel flanges and a connecting web. The flanges are turned at the end. The flanges of the channels MQ-41, MQ-41 D, MQ-41-L and MQ-21.5 are designed with an offset. The turned flange ends are designed with a toothed shape which makes it possible to force-fit the channels to specific channel system fixtures. Different recesses in the back of the channels in the form of oblong holes and round holes allow the use of fasteners and fixtures. The MQ-41 D installation channel consists of two profiles of similar type as MQ-41, which are connected in the area of the holes in the back of the channels in a shape-fitting and force-fitting way as a kind of riveted connection. The channels are delivered in lengths of 2 m, 3 m and 6 m for the channels MQ-41, MQ-41-L and MQ-21.5 and in lengths of 3 m or 6 m for the channels MQ-41/3, MQ-41/3 LL and MQ-41 D. The channels can be cut to length as required.

Annex A describes the dimensions and materials of the Hilti installation channels MQ-41/3, MQ-41/3 LL, MQ-41 D, MQ-21.5, MQ-41 and MQ-41-L.

2 Specification of the intended use in accordance with the applicable European Assessment Document (EAD)

The performance given in Section 3 can only be assumed if the Hilti installation channels MQ-41/3, MQ-41/3 LL, MQ-41 D, MQ-21.5, MQ-41 and MQ-41-L are used in compliance with the specifications and under boundary conditions set out in Annex B. The test and assessment methods on which this European Technical Assessment is based lead to an assumption of a working life of the Hilti installation channels MQ-41/3, MQ-41/3 LL, MQ-41 D, MQ-21.5, MQ-41 and MQ-41-L of at least 50 years in final use under ambient temperatures in indoor areas. The indications given on the working life cannot be interpreted as a guarantee given by the producer, but are to be regarded only as a means for choosing the right products in relation to the expected economically reasonable working life of the works.

In accordance with the European Assessment Document EAD 280016-00-0602, the product is intended to be used in

- a) installations for the support of sprinkler kits;
- b) installations for the support of other building service elements such as pipes, conduits, ducts and cables.

3 Performance of the product and references to the methods used for its assessment

3.1 Safety in case of fire (BWR 2)

Essential characteristic	Performance
Reaction to fire	Class A1

English translation prepared by DIBt

3.2 Safety and accessibility in use (BWR 4)

Essential characteristic	Performance
Shape	see Annex A
Dimensions	see Annex A
Material and cross-section characteristics	see Annex A
Characteristic pull-through resistance of channel back holes at ambient temperature	see Annex C
Pull-through resistance of channel back holes at elevated temperatures	see Annex D
Bending characteristics of the channel at elevated temperatures	see Annex D

4 Assessment and verification of constancy of performance (AVCP) system applied, with reference to its legal base

In accordance with the European Assessment Document EAD 280016-00-0602, the following legal bases apply:

- In case of intended use a) specified in Section 2:
Decision of the commission N° 1996/577/EC:
System 1 applies for the assessment and verification of constancy of performance (AVCP).
- In case of intended use b) specified in Section 2:
Decision of the commission N° 1999/472/EC:
System 3 applies for the assessment and verification of constancy of performance (AVCP).

5 Technical details necessary for the implementation of the AVCP system, as provided for in the applicable EAD

The technical details necessary for the implementation of the system for the assessment and verification of constancy of performance are laid down in the control plan (confidential part of this European Technical Assessment) deposited at Deutsches Institut für Bautechnik.

Issued in Berlin on 26 June 2018 by Deutsches Institut für Bautechnik

BD Dipl.-Ing. Andreas Kummerow
Head of Department

beglaubigt:
Häßler

Table A1: Dimensions and materials of installation channels MQ-41/3, MQ-41/3 LL and MQ-41 D

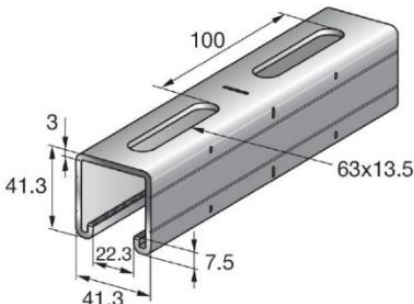
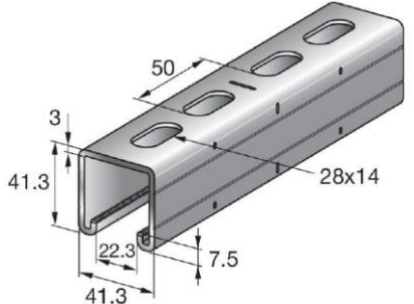
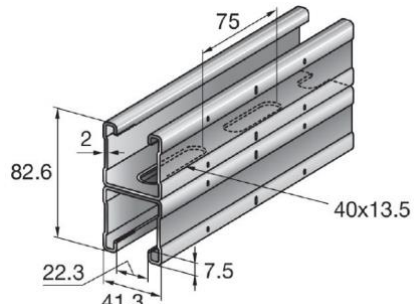
Illustration ¹⁾	Item number	Designation	Length [m]	Materials and coatings
	369596	MQ-41/3 3M	3	S250GD+Z275-M-A-C in accordance with EN 10346
	369597	MQ-41/3 6M	6	
	2048102	MQ-41/3 3M LL	3	S250GD+Z275-M-A-C in accordance with EN 10346
	2048103	MQ-41/3 6M LL	6	
 <p>Two profiles of MQ-41 D channel are connected in the area of the holes in the back of the channels in a shape-fitting and force-fitting way as a kind of riveted connection.</p>	369603	MQ-41 D 3m	3	S250GD+Z275-M-A-C in accordance with EN 10346
	369604	MQ-41 D 6m	6	

¹⁾ Dimensions in mm

Hilti installation channel MQ-41/3, Hilti installation channel MQ-41/3 LL and Hilti installation channel MQ-41 D

Annex A1

Product description
Dimensions and materials

Table A2: Dimensions and materials of installation channels MQ-21.5, MQ-41 and MQ-41-L

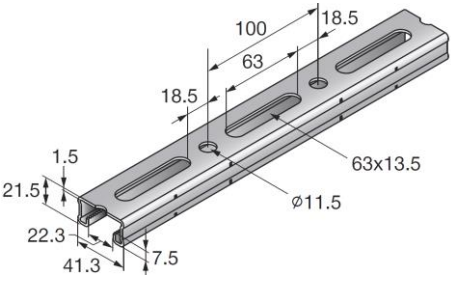
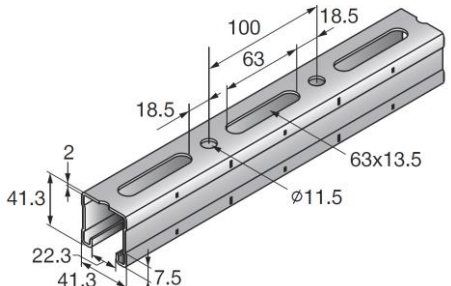
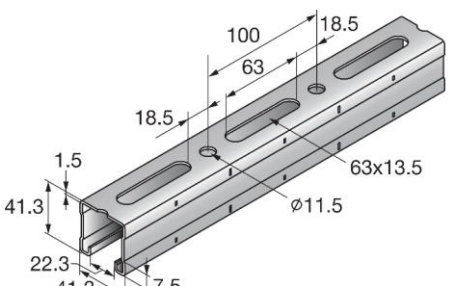
Illustration ²⁾	Item number	Designation	Length [m]	Materials and coatings
	2184773	MQ-21.5 6m	6	S280GD+Z140-M-A-C in accordance with EN 10346
	2184772	MQ-21.5 3m	3	
	2184771	MQ-21.5 2m	2	
	369592	MQ-41 6m	6	S250GD+Z275-M-A-C in accordance with EN 10346
	369591	MQ-41 3m	3	
	304559	MQ-41 2m	2	
	2141964	MQ-41-L 6m	6	S250GD+Z140-M-A-C in accordance with EN 10346
	2141965	MQ-41-L 3m	3	
	2141966	MQ-41-L 2m	2	

²⁾ Dimensions in mm

Hilti installation channel MQ-21.5, Hilti installation channel MQ-41 and
Hilti installation channel MQ-41-L

Annex A2

Product description
Dimensions and materials

- Hilti MQ-41/3, MQ-41/3 LL, MQ-41 D, MQ-21.5, MQ-41 and MQ-41-L installation channels are used to transfer building services component loads such as ducts and equipment for sprinklers, water, heating, cooling, ventilation, electrical and other systems. Hilti MQ-41/3, MQ-41/3 LL, MQ-41 D, MQ-21.5, MQ-41 and MQ-41-L installation channels are performing this loadbearing function under the conditions described in Section 2 of this European Technical Assessment.
- Hilti MQ-41/3, MQ-41/3 LL, MQ-21.5, MQ-41 and MQ-41-L installation channels are used in building services engineering installation systems at ambient and elevated temperatures. Hilti MQ-41 D installation channel in the scope of this European Technical Assessment is used only for applications at ambient temperatures.
- The resistance and deformation at ambient and elevated temperatures apply for static and centric actions.
- The resistance and deformation at elevated temperatures are referring to the boundary conditions of the standard temperature / time curve (STTC) in accordance with EN 1363-1.
- MQ-41/3, MQ-41/3 LL, MQ-21.5, MQ-41 and MQ-41-L channels used in headrail systems are installed with the channel profile open underneath. Tested fire-proof components are attached underneath using Hilti MQA-M10-B, MQA-M12-B or MQA-M16-B pipe ring saddles. The channels are mounted on the base material for use at elevated temperatures using MQZ-L11 or MQZ-L13 drilled plates in conjunction with suitable fasteners. MQ-41/3 and MQ-41/3 LL channels can be mounted on the base material for use at ambient temperatures with suitable fasteners through the longhole without using MQZ-L11 or MQZ-L13 drilled plates. MQ-21.5, MQ-41 and MQ-41-L channels can be mounted on the base material for use at ambient and elevated temperatures with suitable fasteners through the roundhole without using MQZ-L11 or MQZ-L13 drilled plates.
- In the case of suspended channel systems, the channel profiles are opened upwards or downwards. On the underside or on the top of suspended channel systems, tested fireproof components must be force-fitted and secured using Hilti MQZ-L11 or MQZ-L13 drilled plates, nuts and threaded rods. Hilti MQA-M10-B, MQA-M12-B or MQA-M16-B pipe ring saddles can also be used as an alternative. Implementing the nodes between the channel and the threaded rod used for the suspension must take place using force-fitted Hilti MQZ-L11 or MQZ-L13 drilled plates and nuts as well as threaded rods.
- The installation channels are cut to length centrally between the longholes or the roundholes at the marking. The cut channel lies within a range of 2 mm from both sides of the marking.
- Threaded rods and other fixtures are only to be guided through the closed roundholes or longholes in the back of the channel.
- The anchoring used with the base material must be suitable and have a fireproof certificate.
- Prior to installation, it must be ensured that the components to be supported by the installation channels, the connection components, the anchoring of the channels to the base material and the base material itself are suitable to withstand the resistance values of the channels as well as installation systems and that they have a fireproof certificate.
- The installation channels must be installed by appropriately qualified personnel and under the supervision of the site manager. The general installation instructions of the manufacturer apply.

Hilti installation channel MQ-41/3, Hilti installation channel MQ-41/3 LL, Hilti installation channel MQ-41 D, Hilti installation channel MQ-21.5, Hilti installation channel MQ-41 and Hilti installation channel MQ-41-L	Annex B1
Requirements for performance assessment	

- The pull-through resistance from the holes in the back of the channels at ambient and elevated temperatures results in connection with the fasteners as per Table B2.

Table B2: Fasteners for channel fixation through back holes

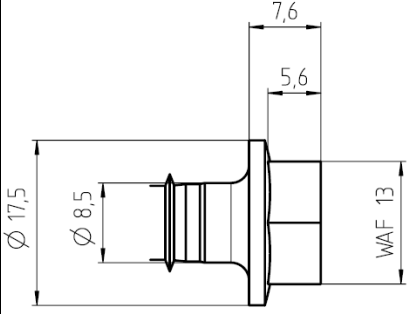
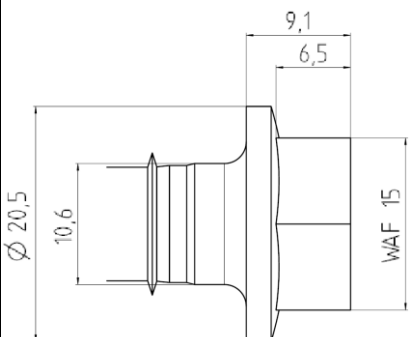
No.	Material and geometry of fastener	Illustration [Dimensions in mm]	Installation channel
1	Steel galvanized, $f_{uk} \geq 810 \text{ N/mm}^2$ Hexagon head, WAF 13 mm		MQ-21.5 (round hole) MQ-41 (round hole) MQ-41-L (round hole)
2	Steel galvanized, $f_{uk} \geq 805 \text{ N/mm}^2$ Hexagon head, WAF 15 mm		MQ-41/3 MQ-41/3 LL
3	Bolt: M12, strength class 4.8 in accordance with DIN 976-1, zinc coated Washer: EN ISO 7089 – 13 – 200 HV, zinc coated Hexagon nut: M12, strength class 8 in accordance with ISO 4032, zinc coated	-	MQ-41/3 MQ-41/3 LL
4	Bolt: M10, strength class 4.8 in accordance with DIN 976-1, zinc coated Washer: EN ISO 7089 – 10.5 – 200 HV, zinc coated Hexagon nut: M10, strength class 8 in accordance with ISO 4032, zinc coated	-	MQ-21.5 (round hole) MQ-41 (round hole) MQ-41-L (round hole)

Hilti installation channel MQ-41/3, Hilti installation channel MQ-41/3 LL,
Hilti installation channel MQ-21.5, Hilti installation channel MQ-41 and
Hilti installation channel MQ-41-L

Annex B2

Requirements for performance assessment

Table B3: Section properties of installation channels

Description	Symbol	MQ-41/3	MQ-41/3 LL	MQ-41 D	MQ-21.5	MQ-41	MQ-41-L	Unit
Classification cross section in accordance with EN 1993-1-1	-	3	3	3	3	3	3	-
Cross section areas	A	375.88	379.93	545.97	142.71	263.62	199.57	mm ²
	A _{tot}	375.88	379.93	545.97	142.71	263.62	199.57	mm ²
Shear areas	A _y	48.69	54.43	66.37	23.47	27.23	20.24	mm ²
	A _z	195.47	194.59	197.58	41.86	131.51	98.37	mm ²
Centroid position	y _{C,0}	19.15	19.15	0.00	0.00	19.65	0.00	mm
	z _{C,0}	20.57	20.76	0.00	-9.12	20.52	-19.91	mm
Moments of inertia	I _y	76963.50	78224.80	323585.00	9168.75	57501.00	44773.00	mm ⁴
	I _z	107949.00	108011.00	154070.00	37416.40	76416.00	58981.50	mm ⁴
Inclination of principal axes	α	90.00	90.00	0.00	90.00	90.00	90.00	°
Polar moments of inertia	I _p	184913.00	186236.00	477656.00	46585.10	133917.00	103754.00	mm ⁴
	I _{p,M}	778900.00	780561.00	477656.00	115093.00	601859.00	469974.00	mm ⁴
Radii of gyration	i _y	14.31	14.35	24.35	8.02	14.77	14.98	mm
	i _z	16.95	16.86	16.80	16.19	17.03	17.19	mm
Polar radii of gyration	i _p	22.18	22.14	29.58	18.07	22.54	22.80	mm
	i _{p,M}	45.52	45.33	29.58	28.40	47.78	48.53	mm
Warping radius of gyration	i _{ω,M}	7.02	7.02	17.32	6.85	7.19	7.44	mm
Torsional constant	J	848.88	856.29	575.03	76.58	269.75	112.13	mm ⁴
Secondary torsional constant	J _s	105319.00	105394.00	91246.30	25157.50	74075.40	565590.00	mm ⁴
Location of the shear center	y _{M,0}	19.15	19.15	0.00	0.00	19.65	0.00	mm
	z _{M,0}	60.32	60.31	0.00	12.77	62.63	22.92	mm
	y _M	0.00	0.00	0.00	0.00	0.00	0.00	mm
	z _M	39.75	39.55	0.00	21.90	42.11	42.84	mm
Warping constants	I _{ω,C}	2.09277E+08	2.07678E+08	1.43225E+08	23255400.00	1.66135E+08	1.34296E+08	mm ⁶
	I _{ω,M}	38387600	38417600.00	1.43225E+08	5395050.00	31116700.00	26017600	mm ⁶
	r _{ω,M}	0.00	0.00	0.00	0.00	0.00	0.00	-
Section moduli	S _{y,max}	4002.48	4108.45	7834.29	928.54	2906.72	2248.07	mm ³
	S _{y,min}	-3487.10	-3514.15	-7833.74	-788.66	-2672.22	-2093.62	mm ³
	S _{z,max}	5227.58	5230.56	7460.71	1811.93	3700.53	2856.29	mm ³
	S _{z,min}	-5277.58	-5230.56	-7460.71	-1811.93	-3700.54	-2856.25	mm ³
Torsional section modulus	S _t	282.96	285.43	287.51	51.06	134.88	75.76	mm ³
Max. plastic bending moment	M _{pl,y,k}	NPA ³⁾	NPA	NPA	NPA	NPA	NPA	kNm
	M _{pl,z,k}	NPA	NPA	NPA	NPA	NPA	NPA	kNm
Max. plastic section moduli	Z _y	NPA	NPA	NPA	NPA	NPA	NPA	mm ³
	Z _z	NPA	NPA	NPA	NPA	NPA	NPA	mm ³
Plastic shear areas	A _{pl,y}	NPA	NPA	NPA	NPA	NPA	NPA	mm ²
	A _{pl,z}	NPA	NPA	NPA	NPA	NPA	NPA	mm ²
Area bisecting axis position	f _{y,0}	NPA	NPA	NPA	NPA	NPA	NPA	mm
	f _{z,0}	NPA	NPA	NPA	NPA	NPA	NPA	mm
Plastic shear forces	V _{pl,y,k}	NPA	NPA	NPA	NPA	NPA	NPA	kN
	V _{pl,z,k}	NPA	NPA	NPA	NPA	NPA	NPA	kN
Plastic axial force	N _{pl,k}	NPA	NPA	NPA	NPA	NPA	NPA	kN
Buckling curves	BC _y	c	c	c	c	c	c	-
	BC _z	c	c	c	c	c	c	-

³⁾ NPA: No performance assessed

Hilti installation channel MQ-41/3, Hilti installation channel MQ-41/3 LL, Hilti installation channel MQ-41 D, Hilti installation channel MQ-21.5, Hilti installation channel MQ-41 and Hilti installation channel MQ-41-L

Annex B3

Requirements for performance assessment

Table C1: Characteristic pull-through resistance from the holes in the back of the channels at ambient temperatures

Installation channel	Characteristic pull-through resistance ⁴⁾	Partial safety coefficient ⁵⁾
	F_{RK} [kN]	γ_M
MQ-41/3	13.01	2.32
MQ-41/3 LL		
MQ-41 D	NPA ⁶⁾	–
MQ-21.5	11.95	2.85
MQ-41	17.54	4.17
MQ-41-L	8.59	2.05

⁴⁾ For MQ-41/3 and MQ-41/3 LL, the performance applies regardless of the position of the fastener in the longholes in the back of the channels;
For MQ-21.5, MQ-41 und MQ-41-L, the performance applies with the position of the fastener in the roundholes in the back of the channels.

⁵⁾ provided that no other national regulations apply

⁶⁾ NPA: No performance assessed

Hilti installation channel MQ-41/3, Hilti installation channel MQ-41/3 LL,
Hilti installation channel MQ-41 D, Hilti installation channel MQ-21.5,
Hilti installation channel MQ-41 and Hilti installation channel MQ-41-L

Annex C

Characteristic pull-through resistance of channel back holes at ambient temperature

Table D1: Pull-through resistance $F_{Rk,t}$ from the roundholes in the back of the channels at elevated temperatures after 30, 60 and 90 minutes

Installation channel	Pull-through resistance		
	$F_{Rk,t}$ [kN]		
	t = 30 minutes	t = 60 minutes	t = 90 minutes
MQ-41	1.92	1.01	0.71
MQ-41-L	1.29	NPA ⁷⁾	NPA
MQ-21.5	1.75	NPA	NPA

⁷⁾ NPA: No performance assessed

Table D2.1: Channel material stress⁸⁾ at different temperatures of the component and $\epsilon_{B,0a} = 2\%$

Temperature [°C]	Stress [N/mm ²]			
	MQ-41/3 or MQ-41/3 LL	MQ-41	MQ-41-L	MQ-21.5
800	26.51	25.06	20.83	28.53
842*	19.00	16.77	14.11	21.80
850	17.57	15.19	12.83	20.52
900	12.82	11.21	10.69	17.24
945*	12.05	10.49	9.19	12.91
950	11.96	10.41	9.02	12.43
1000	10.58	8.82	7.02	10.52
1006*	10.50	8.72	6.98	10.48
1049*	9.91	7.97	6.73	10.18
1050	9.90	7.96	6.73	10.17

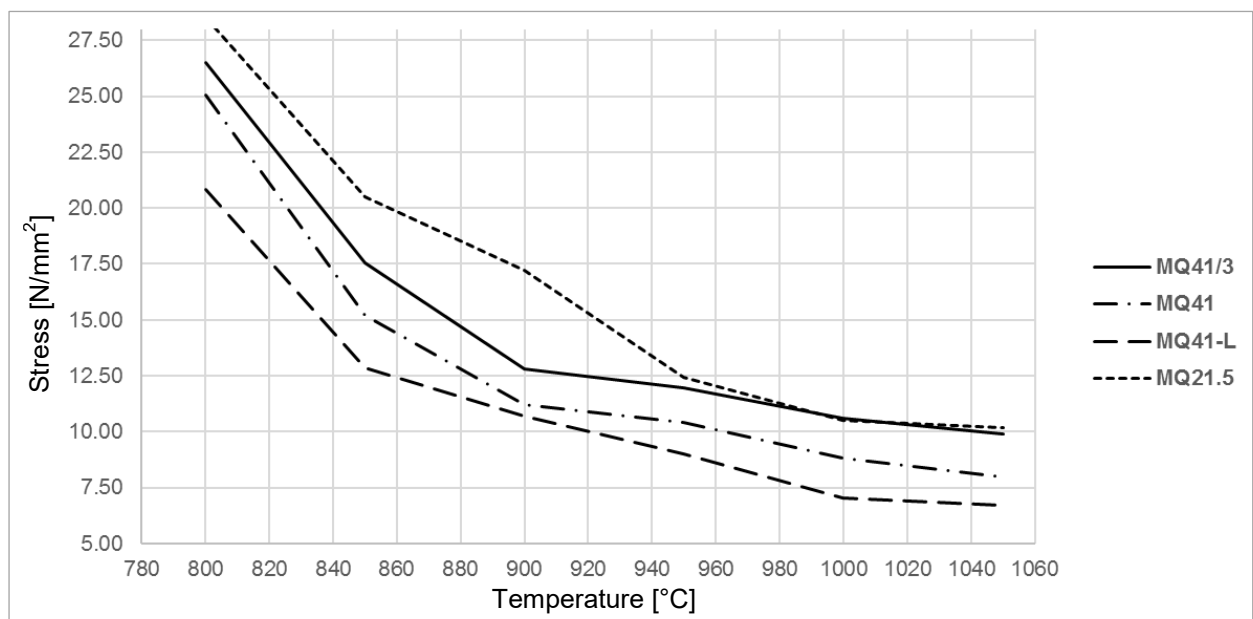

⁸⁾ determined based on unsteady thermal creep tests

⁹⁾ interpolated values of the channel material stress

Table D2.2: Temperatures⁹⁾ after 30, 60, 90 and 120 minutes according to standard temperature / time curve (STTC)

Time according to STTC [min]	30	60	90	120
Temperature [°C]	842	945	1006	1049

⁹⁾ Furnace temperatures according to STTC;

It can be assumed that the component temperature corresponds to the furnace temperature.

Hilti installation channel MQ-41/3, Hilti installation channel MQ-41/3 LL,
Hilti installation channel MQ-21.5, Hilti installation channel MQ-41 and
Hilti installation channel MQ-41-L

Annex D2

Stress-strain behaviour at elevated temperatures

Table D3: Calculation-based deformation at elevated temperatures for installation channels MQ-41/3 and MQ-41/3 LL

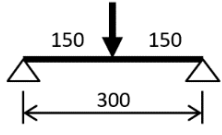
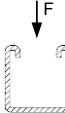
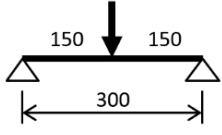
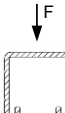
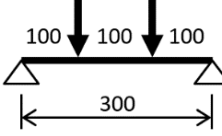
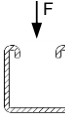
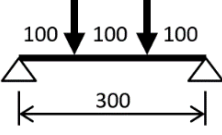
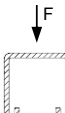
System [Dimensions in mm]	Load direction	σ_B	$V^{(10)}$	$F^{(11)}$	$\delta_{t_{max};B}$	$t_{max,B}$	δ_{30}	δ_{60}	δ_{90}	δ_{120}
		[N/mm ²]	-	[N]	[mm]	[min]	[mm]	[mm]	[mm]	[mm]
		5	0.50	228.38	35.53	120.00	1.38	13.86	21.48	35.53
		10	0.50	461.05	38.74	120.00	2.26	15.52	24.24	38.74
		15	0.50	693.72	44.14	120.00	3.45	18.00	28.31	44.14
		20	0.50	926.38	59.74	120.00	4.98	23.86	38.03	59.74
		25	0.50	1159.05	72.32	107.09	7.14	32.54	55.25	152.22
		30	0.50	1391.72	60.10	73.76	10.48	45.71	152.09	152.22
		5	0.50	228.38	35.47	120.00	1.37	13.83	21.43	35.47
		10	0.50	461.05	37.88	120.00	2.02	15.09	23.50	37.88
		15	0.50	693.72	42.03	120.00	3.00	17.03	26.64	42.03
		20	0.50	926.38	51.00	120.00	4.18	20.82	32.85	51.00
		25	0.50	1159.05	37.29	80.01	5.79	26.79	70.44	102.25
		30	0.50	1391.72	26.13	46.68	8.17	61.69	-	-
		5	0.67	171.29	35.90	120.00	1.43	14.06	21.85	35.90
		10	0.67	345.79	40.56	120.00	2.73	16.34	25.63	40.56
		15	0.67	520.29	52.67	120.00	4.32	21.31	33.87	52.67
		20	0.67	694.79	75.00	120.00	6.69	31.03	49.89	75.00
		25	0.67	869.29	84.98	107.92	10.66	43.74	68.22	152.22
		30	0.67	1043.79	72.10	74.59	18.43	58.97	152.09	152.22
		5	0.67	171.29	35.75	120.00	1.42	13.99	21.70	35.75
		10	0.67	345.79	39.43	120.00	2.48	15.84	24.74	39.43
		15	0.67	520.29	46.04	120.00	3.75	18.89	29.65	46.04
		20	0.67	694.79	61.98	120.00	5.49	25.54	40.35	61.98
		25	0.67	869.29	64.98	100.42	7.99	34.69	54.92	-
		30	0.67	1043.79	53.97	68.34	12.00	46.05	-	-

¹⁰⁾ Momentum degree of fullness without contribution from channel dead weight

¹¹⁾ Size of the designated system's single load

Symbols and designation

ϵ_{B,θ_a}	Channel bending strain at elevated temperatures θ_a
σ_B	Channel bending stress
V	Momentum degree of fullness
F	Load
$\delta_{t_{max};B}$	Deformation of the channel at the point in time of stability failure or of the plastic hinging
$t_{max,B}$	Time in which loss of rigidity or plastic hinging of the channel occurs under bending stress
δ_{30}	Displacement after exposure time of 30 minutes to elevated temperatures
δ_{60}	Displacement after exposure time of 60 minutes to elevated temperatures
δ_{90}	Displacement after exposure time of 90 minutes to elevated temperatures
δ_{120}	Displacement after exposure time of 120 minutes to elevated temperatures

Thermal analyses as well as calculations are referring to the boundary conditions of STTC.

Hilti installation channel MQ-41/3 and Hilti installation channel MQ-41/3 LL

Annex D3

Bending characteristics of the channel at elevated temperatures

Table D4: Calculation-based deformation at elevated temperatures for installation channels MQ-41/3 and MQ-41/3 LL

System [Dimensions in mm]	Load direction	σ_B	$V^{(10)}$	$F^{(11)}$	$\delta_{t_{max},B}$	$t_{max,B}$	δ_{30}	δ_{60}	δ_{90}	δ_{120}
		[N/mm ²]	-	[N]	[mm]	[min]	[mm]	[mm]	[mm]	[mm]
		5	0.5	132.46	36.39	120.00	1.59	14.33	22.24	36.39
		10	0.5	272.06	44.98	120.00	3.95	18.71	29.54	44.98
		15	0.5	411.66	62.13	120.00	7.10	26.15	41.96	62.13
		20	0.5	551.26	104.64	120.00	11.31	42.64	69.55	104.64
		25	0.5	690.86	117.01	98.34	17.56	66.29	105.99	199.40
		30	0.5	830.46	106.27	68.76	28.04	94.16	248.76	253.70
		5	0.5	132.46	36.06	120.00	1.54	14.16	21.93	36.06
		10	0.5	272.06	41.96	120.00	3.18	17.24	27.02	41.96
		15	0.5	411.66	51.24	120.00	5.52	21.66	34.21	51.24
		20	0.5	551.26	72.77	120.00	8.29	31.01	49.06	72.77
		25	0.5	690.86	102.25	120.00	12.06	44.70	70.44	102.25
		30	0.5	830.46	86.77	81.26	17.55	61.69	-	-
		5	0.80	165.58	38.33	120.00	1.94	15.38	24.11	38.33
		10	0.80	340.08	54.75	120.00	6.39	23.04	36.94	54.75
		15	0.80	514.58	105.04	84.17	11.77	47.40	148.06	184.14
		20	0.80	689.08	93.67	49.18	21.26	194.92	235.68	253.70
		25	0.80	863.58	35.68	27.93	163.26	225.24	253.48	253.70
		30	0.80	1038.08	27.05	23.35	187.95	243.73	253.48	253.70
		5	0.80	165.58	36.97	120.00	1.72	14.65	22.78	36.97
		10	0.80	340.08	47.37	120.00	4.71	19.92	31.41	47.37
		15	0.80	514.58	64.51	120.00	8.21	28.07	44.34	64.51
		20	0.80	689.08	90.89	113.75	12.98	45.55	68.48	-
		25	0.80	863.58	74.29	69.17	20.08	64.16	-	-
		30	0.80	1038.08	64.08	42.09	31.28	-	-	-
		5	0.67	55.19	37.41	120.00	1.78	14.88	23.23	37.41
		10	0.67	113.36	50.00	120.00	5.32	21.09	33.48	50.00
		15	0.67	171.53	78.05	120.00	9.55	34.01	53.83	78.05
		20	0.67	229.69	113.97	120.00	15.78	56.14	83.44	113.97
		25	0.67	287.86	140.77	120.00	25.97	77.66	108.87	140.77
		30	0.67	346.03	162.19	117.50	42.50	96.39	129.74	207.98
		5	0.67	55.19	36.61	120.00	1.65	14.45	22.45	36.61
		10	0.67	113.36	45.17	120.00	4.11	18.85	29.65	45.17
		15	0.67	171.53	59.59	120.00	7.16	25.58	40.49	59.59
		20	0.67	229.69	89.54	120.00	11.11	39.97	62.32	89.54
		25	0.67	287.86	83.60	85.00	16.79	58.32	-	-
		30	0.67	346.03	75.29	56.26	25.67	-	-	-

¹⁰⁾ Momentum degree of fullness without contribution from channel dead weight

¹¹⁾ Size of the designated system's single load

Symbols and designation see Annex D3

Hilti installation channel MQ-41/3 and Hilti installation channel MQ-41/3 LL

Annex D4

Bending characteristics of the channel at elevated temperatures

Table D5: Calculation-based deformation at elevated temperatures for installation channels MQ-41/3 and MQ-41/3 LL

System [Dimensions in mm]	Load direction	σ_B	$V^{(10)}$	$F^{(11)}$	$\delta_{t_{max},B}$	$t_{max,B}$	δ_{30}	δ_{60}	δ_{90}	δ_{120}
		[N/mm ²]	-	[N]	[mm]	[min]	[mm]	[mm]	[mm]	[mm]
		5	0.5	89.72	37.80	120.00	1.95	15.09	23.49	37.80
		10	0.5	189.44	54.69	120.00	6.59	23.71	37.82	54.69
		15	0.5	289.15	88.10	120.00	12.77	38.85	62.36	88.10
		20	0.5	388.87	152.11	120.00	21.01	68.99	107.88	152.11
		25	0.5	488.58	199.40	120.00	33.45	105.09	155.72	199.40
		30	0.5	588.29	183.72	85.00	53.13	141.14	248.76	355.17
		5	0.5	89.72	36.93	120.00	1.81	14.63	22.66	36.93
		10	0.5	189.44	47.65	120.00	4.80	20.26	31.93	47.65
		15	0.5	289.15	64.63	120.00	9.03	28.38	45.13	64.63
		20	0.5	388.87	101.06	120.00	14.08	45.02	70.98	101.06
		25	0.5	488.58	126.68	105.42	20.88	68.18	104.23	-
		30	0.5	588.29	113.11	71.26	30.90	94.77	-	-
		5	0.86	157.01	41.88	120.00	2.66	17.27	27.42	41.88
		10	0.86	331.51	107.73	120.00	11.89	33.30	56.92	107.73
		15	0.86	506.01	184.14	120.00	23.34	104.82	148.06	184.14
		20	0.86	680.51	51.98	29.18	127.10	194.92	235.68	270.33
		25	0.86	855.01	36.27	24.18	163.26	225.24	259.10	295.75
		30	0.86	1029.51	33.65	22.10	187.95	243.73	280.16	311.98
		5	0.86	157.01	38.58	120.00	2.15	15.51	24.19	38.58
		10	0.86	331.51	58.11	120.00	7.54	25.49	40.47	58.11
		15	0.86	506.01	87.14	120.00	14.35	40.19	63.12	87.14
		20	0.86	680.51	96.76	86.25	23.43	67.99	-	-
		25	0.86	855.01	82.43	46.26	36.63	-	-	-
		30	0.86	1029.51	75.31	34.60	54.77	-	-	-
		5	0.67	26.17	39.84	120.00	2.32	16.20	25.46	39.84
		10	0.67	55.25	64.06	120.00	9.24	28.26	45.22	64.06
		15	0.67	84.34	107.50	120.00	17.42	51.92	79.27	107.50
		20	0.67	113.42	152.23	120.00	29.17	85.21	118.31	152.23
		25	0.67	142.50	183.14	120.00	46.78	112.45	147.95	183.14
		30	0.67	171.59	207.98	120.00	69.55	134.11	171.86	207.98
		5	0.67	26.17	37.87	120.00	1.99	15.14	23.53	37.87
		10	0.67	55.25	53.20	120.00	6.39	23.07	36.52	53.20
		15	0.67	84.34	77.89	120.00	11.90	34.90	55.32	77.89
		20	0.67	113.42	121.08	120.00	18.96	58.94	89.09	121.08
		25	0.67	142.50	107.19	75.01	29.18	86.80	-	-
		30	0.67	171.59	95.91	44.59	44.40	-	-	-

¹⁰⁾ Momentum degree of fullness without contribution from channel dead weight

¹¹⁾ Size of the designated system's single load

Symbols and designation see Annex D3

Hilti installation channel MQ-41/3 and Hilti installation channel MQ-41/3 LL

Annex D5

Bending characteristics of the channel at elevated temperatures

Table D6: Calculation-based deformation at elevated temperatures for installation channels MQ-41/3 and MQ-41/3 LL

System [Dimensions in mm]	Load direction	σ_B	$V^{(10)}$	$F^{(1)}$	$\delta_{t_{max};B}$	$t_{max,B}$	δ_{30}	δ_{60}	δ_{90}	δ_{120}
		[N/mm ²]	-	[N]	[mm]	[min]	[mm]	[mm]	[mm]	[mm]
		5	0.5	64.71	39.79	120.00	2.45	16.18	25.27	39.79
		10	0.5	142.26	67.91	120.00	10.22	30.54	49.10	67.91
		15	0.5	219.82	118.55	120.00	20.45	55.34	87.37	118.55
		20	0.5	297.38	202.14	120.00	33.90	99.74	149.83	202.14
		25	0.5	374.93	256.64	120.00	53.47	146.62	207.67	256.64
		30	0.5	452.49	292.63	119.17	82.09	191.04	248.76	359.01
		5	0.5	64.71	38.05	120.00	2.16	15.25	23.61	38.05
		10	0.5	142.26	54.62	120.00	6.81	23.98	37.96	54.62
		15	0.5	219.82	81.28	120.00	13.36	36.82	58.71	81.28
		20	0.5	297.38	132.14	120.00	21.28	61.67	96.20	132.14
		25	0.5	374.93	153.03	95.84	31.96	95.35	140.86	-
		30	0.5	452.49	142.98	65.01	47.38	131.00	-	-
		5	0.89	145.60	46.41	120.00	3.55	19.65	31.63	46.41
		10	0.89	320.10	149.86	120.00	19.22	48.31	110.45	149.86
		15	0.89	494.60	211.68	120.00	40.54	136.35	176.46	211.68
		20	0.89	669.10	61.78	27.10	127.10	194.92	235.68	270.33
		25	0.89	843.60	85.46	22.93	163.26	225.24	259.10	295.75
		30	0.89	1018.10	36.98	20.85	187.95	243.73	280.16	311.98
		5	0.89	145.60	40.02	120.00	2.55	16.27	25.41	40.02
		10	0.89	320.10	69.45	120.00	10.47	31.58	50.23	69.45
		15	0.89	494.60	107.88	120.00	21.20	52.17	81.08	107.88
		20	0.89	669.10	105.36	74.17	34.71	87.33	-	-
		25	0.89	843.60	90.19	40.01	53.46	-	-	-
		30	0.89	1018.10	81.33	30.85	75.45	-	-	-
		5	0.67	14.56	43.33	120.00	3.11	18.12	28.66	43.33
		10	0.67	32.01	82.40	120.00	14.59	37.91	60.70	82.40
		15	0.67	49.46	138.22	120.00	27.91	73.38	107.23	138.22
		20	0.67	66.91	189.41	120.00	46.31	115.49	153.39	189.41
		25	0.67	84.36	224.43	120.00	71.01	146.93	186.41	224.43
		30	0.67	101.81	251.27	120.00	97.80	171.55	212.61	251.27
		5	0.67	14.56	39.48	120.00	2.43	16.00	24.92	39.48
		10	0.67	32.01	63.24	120.00	9.14	28.36	45.10	63.24
		15	0.67	49.46	99.34	120.00	17.84	46.34	73.19	99.34
		20	0.67	66.91	154.86	118.33	28.82	80.55	117.81	-
		25	0.67	84.36	134.87	70.01	44.29	116.77	-	-
		30	0.67	101.81	122.14	42.09	66.19	-	-	-

¹⁰⁾ Momentum degree of fullness without contribution from channel dead weight

¹¹⁾ Size of the designated system's single load

Symbols and designation see Annex D3

Hilti installation channel MQ-41/3 and Hilti installation channel MQ-41/3 LL

Annex D6

Bending characteristics of the channel at elevated temperatures

Table D7: Calculation-based deformation at elevated temperatures for installation channels MQ-41/3 and MQ-41/3 LL

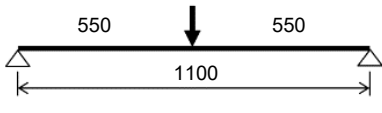
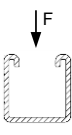
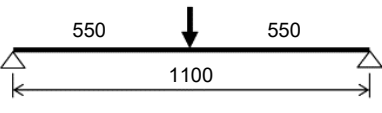
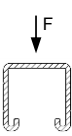
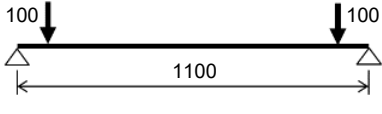
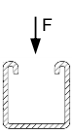
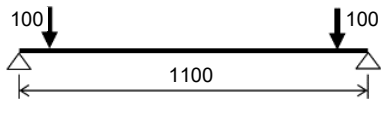
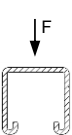
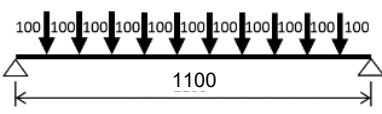
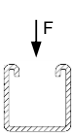
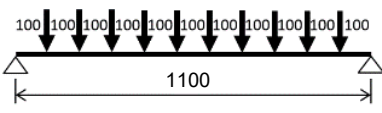
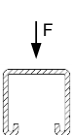
System [Dimensions in mm]	Load direction	σ_B	$V^{10)}$	$F^{11)}$	$\delta_{t_{max},B}$	$t_{max,B}$	δ_{30}	δ_{60}	δ_{90}	δ_{120}
		[N/mm ²]	-	[N]	[mm]	[min]	[mm]	[mm]	[mm]	[mm]
		5	0.5	47.75	42.50	120.00	3.11	17.65	27.69	42.50
		10	0.5	111.21	84.54	120.00	14.91	39.28	63.33	84.54
		15	0.5	174.66	152.99	120.00	30.10	75.44	116.60	152.99
		20	0.5	238.12	253.18	120.00	49.85	133.85	194.08	253.18
		25	0.5	301.57	316.03	120.00	77.29	190.76	261.37	316.03
		30	0.5	365.03	359.01	120.00	114.60	243.07	309.53	359.01
		5	0.5	47.75	39.43	120.00	2.60	16.00	24.75	39.43
		10	0.5	111.21	62.88	120.00	9.18	28.41	45.17	62.88
		15	0.5	174.66	100.75	120.00	18.49	46.87	74.69	100.75
		20	0.5	238.12	164.99	120.00	29.80	80.61	123.97	164.99
		25	0.5	301.57	173.86	84.59	45.13	125.07	-	-
		30	0.5	365.03	166.08	55.43	66.60	-	-	-
		5	0.91	131.32	51.73	120.00	4.58	22.39	36.55	51.73
		10	0.91	305.82	172.29	120.00	28.45	75.38	136.81	172.29
		15	0.91	480.32	238.74	120.00	69.86	159.36	202.29	238.74
		20	0.91	654.82	270.33	120.00	127.10	194.92	235.68	270.33
		25	0.91	829.32	295.75	120.00	163.26	225.24	259.10	295.75
		30	0.91	1003.82	311.98	120.00	187.95	243.73	280.16	311.98
		5	0.91	131.32	41.80	120.00	3.08	17.22	26.90	41.80
		10	0.91	305.82	82.66	120.00	13.81	38.72	61.53	82.66
		15	0.91	480.32	133.06	120.00	29.49	67.01	102.73	133.06
		20	0.91	654.82	120.45	66.67	48.43	108.91	-	-
		25	0.91	829.32	105.72	36.68	73.31	-	-	-
		30	0.91	1003.82	96.53	29.60	-	-	-	-
		5	0.67	8.75	48.11	120.00	4.21	20.75	33.09	48.11
		10	0.67	20.39	104.47	120.00	21.42	50.06	79.62	104.47
		15	0.67	32.02	169.62	120.00	40.92	97.01	136.36	169.62
		20	0.67	43.65	225.92	120.00	66.46	145.97	188.02	225.92
		25	0.67	55.29	265.07	120.00	97.11	181.01	224.76	265.07
		30	0.67	66.92	294.94	120.00	126.94	208.33	253.36	294.94
		5	0.67	8.75	41.46	120.00	2.98	17.07	26.64	41.46
		10	0.67	20.39	75.04	120.00	12.35	34.66	55.26	75.04
		15	0.67	32.02	123.62	120.00	24.83	59.74	93.74	123.62
		20	0.67	43.65	170.13	105.00	40.54	103.90	147.69	-
		25	0.67	55.29	154.72	62.09	62.06	149.82	-	-
		30	0.67	66.92	141.72	38.76	90.20	-	-	-

¹⁰⁾ Momentum degree of fullness without contribution from channel dead weight

¹¹⁾ Size of the designated system's single load



Symbols and designation see Annex D3

Hilti installation channel MQ-41/3 and Hilti installation channel MQ-41/3 LL

Annex D7

Bending characteristics of the channel at elevated temperatures

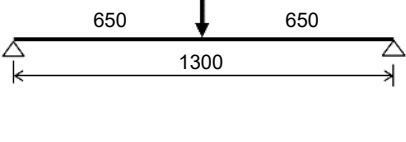
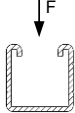
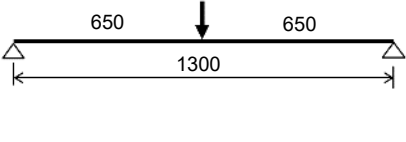
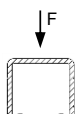
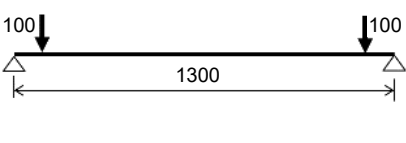
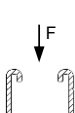
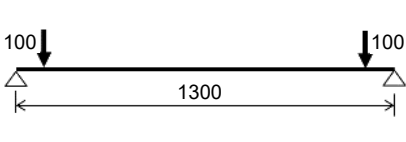
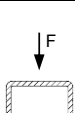
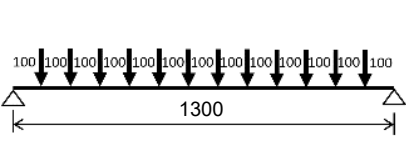
Table D8: Calculation-based deformation at elevated temperatures for installation channels MQ-41/3 and MQ-41/3 LL

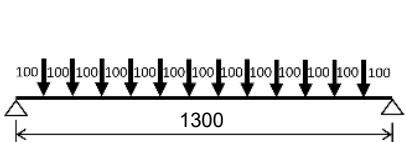
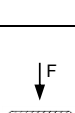
System [Dimensions in mm]	Load direction	σ_B	$V^{(10)}$	$F^{(11)}$	$\delta_{t_{max},B}$	$t_{max,B}$	δ_{30}	δ_{60}	δ_{90}	δ_{120}
		[N/mm ²]	-	[N]	[mm]	[min]	[mm]	[mm]	[mm]	[mm]
		5	0.5	35.14	46.07	120.00	3.95	19.58	30.91	46.07
		10	0.5	88.83	104.75	120.00	20.73	50.08	80.71	104.75
		15	0.5	142.52	190.06	120.00	41.80	98.83	149.08	190.06
		20	0.5	196.21	303.18	120.00	68.74	170.20	238.68	303.18
		25	0.5	249.91	375.68	120.00	104.42	235.35	314.72	375.68
		30	0.5	303.60	425.50	120.00	149.25	294.87	370.85	425.50
		5	0.5	35.14	41.13	120.00	3.14	16.93	26.18	41.13
		10	0.5	88.83	72.85	120.00	11.94	33.78	53.87	72.85
		15	0.5	142.52	123.63	120.00	24.52	58.78	93.54	123.63
		20	0.5	196.21	201.19	120.00	39.94	102.56	155.13	201.19
		25	0.5	249.91	182.28	71.26	60.79	158.01	-	-
		30	0.5	303.60	155.87	40.01	89.37	-	-	-
		5	0.92	114.19	57.49	120.00	5.70	25.32	41.84	57.49
		10	0.92	288.69	195.07	120.00	39.80	103.44	158.37	195.07
		15	0.92	463.19	264.07	120.00	96.84	177.89	225.18	264.07
		20	0.92	637.69	309.47	120.00	149.84	223.77	270.02	309.47
		25	0.92	812.19	334.61	120.00	186.59	254.48	298.33	334.61
		30	0.92	986.69	349.63	120.00	213.06	274.66	315.34	349.63
		5	0.92	114.19	43.73	120.00	3.69	18.26	28.51	43.73
		10	0.92	288.69	97.08	120.00	17.48	46.60	73.98	97.08
		15	0.92	463.19	152.03	112.50	38.90	83.71	126.18	-
		20	0.92	637.69	113.56	45.01	64.10	-	-	-
		25	0.92	812.19	95.46	30.01	95.34	-	-	-
		30	0.92	986.69	92.10	26.26	-	-	-	-
		5	0.67	5.44	54.46	120.00	5.70	24.28	38.98	54.46
		10	0.67	13.75	129.56	120.00	29.82	64.68	101.48	129.56
		15	0.67	22.06	201.47	120.00	56.33	121.83	166.04	201.47
		20	0.67	30.37	261.82	120.00	88.88	176.19	222.06	261.82
		25	0.67	38.68	304.81	120.00	124.15	214.59	262.42	304.81
		30	0.67	46.99	337.85	120.00	156.62	244.37	293.72	337.85
		5	0.67	5.44	43.91	120.00	3.64	18.39	28.76	43.91
		10	0.67	13.75	89.18	120.00	16.08	42.21	67.35	89.18
		15	0.67	22.06	150.92	120.00	33.01	75.28	117.01	150.92
		20	0.67	30.37	174.17	85.42	54.33	129.32	-	-
		25	0.67	38.68	145.31	42.09	82.78	-	-	-
		30	0.67	46.99	126.36	30.85	116.76	-	-	-

¹⁰⁾ Momentum degree of fullness without contribution from channel dead weight

¹¹⁾ Size of the designated system's single load

Symbols and designation see Annex D3

Hilti installation channel MQ-41/3 and Hilti installation channel MQ-41/3 LL

Annex D8

Bending characteristics of the channel at elevated temperatures

Table D9: Calculation-based deformation at elevated temperatures for installation channel MQ-41

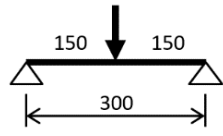
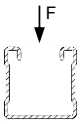
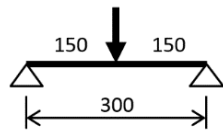
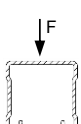
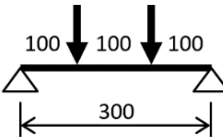
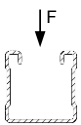
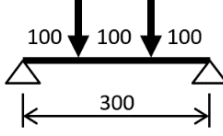
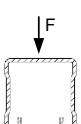
System [Dimensions in mm]	Load direction	σ_B	$V^{10)}$	$F^{11)}$	$\delta_{t_{max};B}$	$t_{max,B}$	δ_{30}	δ_{60}	δ_{90}	δ_{120}
		[N/mm ²]	-	[N]	[mm]	[min]	[mm]	[mm]	[mm]	[mm]
		5	0.5	175.10	5.70	120.00	5.70	5.70	5.70	5.70
		10	0.5	353.25	7.23	120.00	6.76	6.76	6.76	7.23
		15	0.5	531.40	17.95	93.33	8.09	9.99	16.44	58.20
		20	0.5	709.55	18.34	43.33	10.27	68.30	135.70	152.22
		25	0.5	887.70	19.05	31.67	14.27	151.91	152.09	152.22
		30	0.5	1065.84	18.91	28.34	143.70	151.91	-	-
		5	0.5	175.10	5.76	120.00	5.76	5.76	5.76	5.76
		10	0.5	353.25	8.26	120.00	6.91	6.91	7.28	8.26
		15	0.5	531.40	17.06	96.67	8.53	11.33	16.31	50.72
		20	0.5	709.55	17.49	40.00	11.36	52.81	152.09	152.22
		25	0.5	887.70	13.87	28.34	33.66	151.91	152.09	-
		30	0.5	1065.84	10.66	23.34	151.60	-	-	-
		5	0.67	131.33	5.94	120.00	5.94	5.94	5.94	5.94
		10	0.67	264.94	10.70	120.00	7.39	7.39	9.47	10.70
		15	0.67	398.55	24.36	120.00	9.45	14.49	20.63	24.36
		20	0.67	532.16	40.28	120.00	13.21	25.13	34.16	40.28
		25	0.67	665.77	42.94	78.33	20.20	36.53	-	-
		30	0.67	799.38	44.37	46.67	31.03	-	-	-
		5	0.67	131.33	6.03	120.00	6.03	6.03	6.03	6.03
		10	0.67	264.94	12.15	120.00	7.61	7.67	10.65	12.15
		15	0.67	398.55	39.57	120.00	10.06	17.35	26.67	39.57
		20	0.67	532.16	43.99	61.67	14.86	41.59	80.71	92.13
		25	0.67	665.77	35.10	31.67	26.62	81.08	-	-
		30	0.67	799.38	20.58	25.00	69.53	-	-	-

¹⁰⁾ Momentum degree of fullness without contribution from channel dead weight

¹¹⁾ Size of the designated system's single load

Symbols and designation see Annex D3

Hilti installation channel MQ-41

Annex D9

Bending characteristics of the channel at elevated temperatures

Table D10: Calculation-based deformation at elevated temperatures for installation channel MQ-41

System [Dimensions in mm]	Load direction	σ_B	$V^{10)}$	$F^{11)}$	$\delta_{t_{max},B}$	$t_{max,B}$	δ_{30}	δ_{60}	δ_{90}	δ_{120}
		[N/mm ²]	-	[N]	[mm]	[min]	[mm]	[mm]	[mm]	[mm]
		5	0.5	101.81	6.76	120.00	6.76	6.76	6.76	6.76
		10	0.5	208.70	20.45	120.00	9.67	13.50	18.21	20.45
		15	0.5	315.59	58.21	120.00	13.47	29.05	45.20	58.21
		20	0.5	422.48	85.13	88.33	20.06	68.34	135.71	213.28
		25	0.5	529.37	87.33	48.33	34.72	189.22	253.48	253.70
		30	0.5	636.26	35.07	26.67	143.66	253.18	-	-
		5	0.5	101.81	6.77	120.00	6.77	6.77	6.77	6.77
		10	0.5	208.70	20.72	120.00	9.72	13.79	18.52	20.72
		15	0.5	315.59	50.72	120.00	13.65	28.36	41.00	50.72
		20	0.5	422.48	53.95	61.67	20.52	52.81	198.93	253.70
		25	0.5	529.37	49.00	33.33	33.66	210.15	253.48	-
		30	0.5	636.26	48.33	28.34	157.90	-	-	-
		5	0.80	127.27	7.77	120.00	7.71	7.71	7.71	7.77
		10	0.80	260.88	31.70	120.00	12.15	20.71	27.92	31.70
		15	0.80	394.49	56.48	95.00	18.98	41.40	54.92	-
		20	0.80	528.10	58.44	45.00	32.96	-	-	-
		25	0.80	661.71	54.82	30.00	54.82	-	-	-
		30	0.80	795.32	19.57	21.67	-	-	-	-
		5	0.80	127.27	8.30	120.00	7.80	7.80	7.95	8.30
		10	0.80	260.88	34.66	120.00	12.39	22.27	30.63	34.66
		15	0.80	394.49	65.54	120.00	19.75	43.95	57.58	65.54
		20	0.80	528.10	92.13	120.00	33.23	64.35	80.71	92.13
		25	0.80	661.71	81.90	61.67	52.41	81.08	-	-
		30	0.80	795.32	78.01	33.33	69.53	-	-	-
		5	0.67	42.42	7.34	120.00	7.34	7.34	7.34	7.34
		10	0.67	86.96	28.41	120.00	11.14	18.21	25.05	28.41
		15	0.67	131.50	60.06	120.00	16.66	36.76	50.94	60.06
		20	0.67	176.03	93.99	120.00	26.88	58.98	78.24	93.99
		25	0.67	220.57	111.05	98.33	44.33	80.45	105.14	160.98
		30	0.67	265.11	109.68	70.00	66.66	100.60	199.35	222.25
		5	0.67	42.42	7.40	120.00	7.40	7.40	7.40	7.40
		10	0.67	86.96	29.50	120.00	11.32	19.00	26.11	29.50
		15	0.67	131.50	67.29	120.00	17.16	39.13	54.88	67.29
		20	0.67	176.03	89.02	83.33	28.17	65.55	126.64	178.15
		25	0.67	220.57	85.94	43.33	48.45	132.52	194.49	249.61
		30	0.67	265.11	71.34	28.34	111.71	190.73	253.48	253.70

¹⁰⁾ Momentum degree of fullness without contribution from channel dead weight

¹¹⁾ Size of the designated system's single load

Symbols and designation see Annex D3

Hilti installation channel MQ-41

Annex D10

Bending characteristics of the channel at elevated temperatures

Table D11: Calculation-based deformation at elevated temperatures for installation channel MQ-41

System [Dimensions in mm]	Load direction	σ_B	$V^{(10)}$	$F^{(11)}$	$\delta_{t_{max};B}$	$t_{max,B}$	δ_{30}	δ_{60}	δ_{90}	δ_{120}
		[N/mm ²]	-	[N]	[mm]	[min]	[mm]	[mm]	[mm]	[mm]
		5	0.5	69.25	8.35	120.00	8.35	8.35	8.35	8.35
		10	0.5	145.59	39.98	120.00	13.98	26.43	35.63	39.98
		15	0.5	221.94	102.55	120.00	21.48	53.98	80.75	102.55
		20	0.5	298.29	143.40	100.00	34.35	100.13	135.71	213.28
		25	0.5	374.64	132.95	53.33	61.57	189.22	292.59	355.17
		30	0.5	450.99	59.71	26.67	143.66	266.68	-	-
		5	0.5	69.25	8.38	120.00	8.38	8.38	8.38	8.38
		10	0.5	145.59	39.91	120.00	14.08	26.68	35.74	39.91
		15	0.5	221.94	96.36	120.00	21.69	53.02	74.88	96.36
		20	0.5	298.29	107.39	68.33	34.76	93.85	198.93	271.50
		25	0.5	374.64	94.81	35.00	59.43	210.15	315.51	-
		30	0.5	450.99	61.79	26.67	157.90	-	-	-
		5	0.86	121.18	15.41	120.00	10.30	13.05	14.75	15.41
		10	0.86	254.79	56.07	120.00	18.97	38.11	49.90	56.07
		15	0.86	388.40	69.64	66.67	32.51	66.21	-	-
		20	0.86	522.01	66.51	31.67	59.19	-	-	-
		25	0.86	655.62	23.60	21.67	-	-	-	-
		30	0.86	789.23	21.22	20.01	-	-	-	-
		5	0.86	121.18	16.28	120.00	10.39	13.75	15.65	16.28
		10	0.86	254.79	61.46	120.00	19.43	41.75	55.21	61.46
		15	0.86	388.40	94.11	120.00	33.40	69.74	85.75	94.11
		20	0.86	522.01	119.52	120.00	54.63	92.87	109.92	119.52
		25	0.86	655.62	114.89	68.33	77.02	109.79	-	-
		30	0.86	789.23	107.29	36.67	94.12	-	-	-
		5	0.67	20.20	12.36	120.00	9.50	10.50	11.84	12.36
		10	0.67	42.47	52.23	120.00	16.83	34.48	46.43	52.23
		15	0.67	64.73	92.70	120.00	27.35	62.43	81.48	92.70
		20	0.67	87.00	129.88	120.00	45.25	90.02	113.53	129.88
		25	0.67	109.27	160.98	120.00	70.01	113.99	140.47	160.98
		30	0.67	131.54	164.21	88.33	94.58	135.57	199.35	222.25
		5	0.67	20.20	12.61	120.00	9.55	10.75	12.10	12.61
		10	0.67	42.47	54.14	120.00	17.08	35.89	48.32	54.14
		15	0.67	64.73	100.02	120.00	28.10	66.50	87.00	100.02
		20	0.67	87.00	144.27	111.67	47.52	97.63	126.64	178.15
		25	0.67	109.27	141.23	68.33	75.76	132.52	194.49	249.61
		30	0.67	131.54	133.11	35.00	111.71	190.73	257.28	286.01

¹⁰⁾ Momentum degree of fullness without contribution from channel dead weight

¹¹⁾ Size of the designated system's single load

Symbols and designation see Annex D3

Hilti installation channel MQ-41

Annex D11

Bending characteristics of the channel at elevated temperatures

Table D12: Calculation-based deformation at elevated temperatures for installation channel MQ-41

System [Dimensions in mm]	Load direction	σ_B	$V^{(10)}$	$F^{(11)}$	$\delta_{t_{max},B}$	$t_{max,B}$	δ_{30}	δ_{60}	δ_{90}	δ_{120}
		[N/mm ²]	-	[N]	[mm]	[min]	[mm]	[mm]	[mm]	[mm]
		5	0.5	50.25	13.20	120.00	10.55	11.42	12.58	13.20
		10	0.5	109.63	64.29	120.00	19.83	43.24	57.56	64.29
		15	0.5	169.01	149.37	120.00	32.05	82.42	120.06	149.37
		20	0.5	228.40	213.28	120.00	52.32	143.39	187.38	213.28
		25	0.5	287.78	226.29	86.67	93.04	189.22	292.59	362.32
		30	0.5	347.16	193.92	43.33	143.66	266.68	-	-
		5	0.5	50.25	13.38	120.00	10.57	11.57	12.77	13.38
		10	0.5	109.63	63.70	120.00	19.89	43.33	57.32	63.70
		15	0.5	169.01	128.95	120.00	32.21	80.63	108.46	128.95
		20	0.5	228.40	162.26	76.67	52.56	126.72	198.93	271.50
		25	0.5	287.78	144.45	38.33	86.37	210.15	315.51	-
		30	0.5	347.16	88.93	26.67	157.90	-	-	-
		5	0.89	113.06	24.94	120.00	13.63	20.83	23.72	24.94
		10	0.89	246.67	76.78	120.00	27.38	56.87	70.06	76.78
		15	0.89	380.28	83.00	50.00	51.06	-	-	-
		20	0.89	513.89	71.39	28.34	-	-	-	-
		25	0.89	647.50	21.73	20.01	-	-	-	-
		30	0.89	781.12	16.95	18.34	-	-	-	-
		5	0.89	113.06	26.09	120.00	13.75	22.27	25.11	26.09
		10	0.89	246.67	89.31	120.00	28.57	63.78	81.25	89.31
		15	0.89	380.28	125.73	120.00	49.75	95.51	115.27	125.73
		20	0.89	513.89	151.51	120.00	77.23	121.28	140.78	151.51
		25	0.89	647.50	151.86	76.67	101.28	140.26	-	-
		30	0.89	781.12	142.60	41.67	120.16	-	-	-
		5	0.67	11.31	21.06	120.00	12.49	17.80	20.17	21.06
		10	0.67	24.67	79.51	120.00	24.48	54.43	71.34	79.51
		15	0.67	38.03	124.55	120.00	41.12	89.01	111.86	124.55
		20	0.67	51.39	163.69	120.00	66.37	120.43	146.80	163.69
		25	0.67	64.75	195.28	120.00	95.48	145.85	175.02	195.28
		30	0.67	78.11	222.25	120.00	121.12	168.00	199.35	222.25
		5	0.67	11.31	20.97	120.00	12.46	17.87	20.13	20.97
		10	0.67	24.67	82.30	120.00	24.72	56.54	74.16	82.30
		15	0.67	38.03	131.58	120.00	42.10	94.61	118.46	131.58
		20	0.67	51.39	178.15	120.00	69.37	129.47	157.98	178.15
		25	0.67	64.75	215.60	113.33	102.08	159.04	194.49	249.61
		30	0.67	78.11	211.13	75.00	131.96	190.73	257.28	286.01

¹⁰⁾ Momentum degree of fullness without contribution from channel dead weight

¹¹⁾ Size of the designated system's single load

Symbols and designation see Annex D3

Hilti installation channel MQ-41

Annex D12

Bending characteristics of the channel at elevated temperatures

Table D13: Calculation-based deformation at elevated temperatures for installation channel MQ-41

System [Dimensions in mm]	Load direction	σ_B	$V^{(10)}$	$F^{(11)}$	$\delta_{t_{max};B}$	$t_{max,B}$	δ_{30}	δ_{60}	δ_{90}	δ_{120}
		[N/mm ²]	-	[N]	[mm]	[min]	[mm]	[mm]	[mm]	[mm]
		5	0.5	37.42	20.43	120.00	13.44	17.70	19.51	20.43
		10	0.5	86.01	92.85	120.00	27.23	63.57	83.49	92.85
		15	0.5	134.59	200.96	120.00	45.10	114.41	163.86	200.96
		20	0.5	183.18	252.09	120.00	73.70	179.55	225.45	252.09
		25	0.5	231.77	294.87	91.67	130.32	243.51	292.59	362.32
		30	0.5	280.35	282.79	70.00	187.10	266.68	-	-
		5	0.5	37.42	20.31	120.00	13.39	17.61	19.41	20.31
		10	0.5	86.01	90.85	120.00	27.14	63.19	82.33	90.85
		15	0.5	134.59	157.21	120.00	44.95	109.47	140.60	157.21
		20	0.5	183.18	237.27	111.67	72.74	156.69	198.93	271.50
		25	0.5	231.77	234.67	70.00	111.64	210.15	315.51	-
		30	0.5	280.35	214.16	36.67	157.90	-	-	-
		5	0.91	102.91	36.43	120.00	17.59	30.10	34.42	36.43
		10	0.91	236.52	95.42	118.33	37.53	74.62	88.36	-
		15	0.91	370.13	97.08	43.33	69.20	-	-	-
		20	0.91	503.75	35.47	21.67	-	-	-	-
		25	0.91	637.36	32.65	20.01	-	-	-	-
		30	0.91	770.97	26.07	18.34	-	-	-	-
		5	0.91	102.91	37.29	120.00	17.81	32.10	35.90	37.29
		10	0.91	236.52	117.85	120.00	39.61	87.20	108.03	117.85
		15	0.91	370.13	159.74	120.00	67.98	122.83	147.09	159.74
		20	0.91	503.75	187.52	120.00	100.87	150.83	174.29	187.52
		25	0.91	637.36	191.04	83.33	126.77	172.16	-	-
		30	0.91	770.97	178.42	45.00	147.35	-	-	-
		5	0.67	6.86	32.65	120.00	16.43	27.43	31.25	32.65
		10	0.67	15.77	108.67	120.00	34.17	76.91	98.24	108.67
		15	0.67	24.68	157.86	120.00	57.62	116.27	143.11	157.86
		20	0.67	33.58	198.14	120.00	89.31	150.66	180.11	198.14
		25	0.67	42.49	231.53	120.00	121.17	178.48	210.58	231.53
		30	0.67	51.40	259.54	120.00	148.67	201.72	236.11	259.54
		5	0.67	6.86	31.80	120.00	16.21	27.05	30.54	31.80
		10	0.67	15.77	112.84	120.00	34.31	80.08	102.48	112.84
		15	0.67	24.68	166.29	120.00	58.90	123.92	151.68	166.29
		20	0.67	33.58	211.30	120.00	93.49	162.53	193.07	211.30
		25	0.67	42.49	249.61	120.00	129.49	193.67	227.32	249.61
		30	0.67	51.40	286.01	120.00	160.36	220.19	257.28	286.01

¹⁰⁾ Momentum degree of fullness without contribution from channel dead weight

¹¹⁾ Size of the designated system's single load

Symbols and designation see Annex D3

Hilti installation channel MQ-41

Annex D13

Bending characteristics of the channel at elevated temperatures

Table D14: Calculation-based deformation at elevated temperatures for installation channel MQ-41

System [Dimensions in mm]	Load direction	σ_B	$V^{(10)}$	$F^{(11)}$	$\delta_{t_{max};B}$	$t_{max;B}$	δ_{30}	δ_{60}	δ_{90}	δ_{120}
		[N/mm ²]	-	[N]	[mm]	[min]	[mm]	[mm]	[mm]	[mm]
		5	0.5	27.92	29.74	120.00	17.08	25.78	28.44	29.74
		10	0.5	69.03	124.98	120.00	36.24	87.10	112.80	124.98
		15	0.5	110.14	249.93	120.00	60.63	148.49	207.15	249.93
		20	0.5	151.25	295.69	120.00	98.02	217.63	264.92	295.69
		25	0.5	192.36	362.32	120.00	169.86	282.46	332.49	362.32
		30	0.5	233.47	344.97	88.33	223.15	315.90	-	-
		5	0.5	27.92	29.47	120.00	17.00	25.58	28.19	29.47
		10	0.5	69.03	122.42	120.00	36.15	86.68	111.39	122.42
		15	0.5	110.14	197.51	120.00	60.52	142.21	178.79	197.51
		20	0.5	151.25	271.50	120.00	96.70	195.73	240.34	271.50
		25	0.5	192.36	315.51	90.00	142.52	244.57	315.51	-
		30	0.5	233.47	300.95	53.33	189.40	-	-	-
		5	0.92	90.73	48.92	120.00	22.10	40.60	46.13	48.92
		10	0.92	224.34	111.70	113.33	49.76	91.37	105.57	-
		15	0.92	357.96	108.38	40.00	85.94	-	-	-
		20	0.92	491.57	27.10	20.01	-	-	-	-
		25	0.92	625.18	21.59	18.34	-	-	-	-
		30	0.92	758.79	20.81	16.67	-	-	-	-
		5	0.92	90.73	49.41	120.00	22.46	42.78	47.57	49.41
		10	0.92	224.34	147.09	120.00	52.23	111.42	135.43	147.09
		15	0.92	357.96	194.90	120.00	87.51	151.80	180.04	194.90
		20	0.92	491.57	225.98	120.00	125.19	181.72	210.20	225.98
		25	0.92	625.18	231.95	88.33	153.60	205.37	-	-
		30	0.92	758.79	213.08	46.67	175.76	-	-	-
		5	0.67	4.32	47.43	120.00	21.42	39.57	45.32	47.43
		10	0.67	10.68	138.64	120.00	45.85	100.90	126.06	138.64
		15	0.67	17.05	192.39	120.00	76.26	144.08	175.18	192.39
		20	0.67	23.41	233.69	120.00	113.26	180.67	213.76	233.69
		25	0.67	29.77	268.80	120.00	147.08	210.94	246.33	268.80
		30	0.67	36.13	298.60	120.00	176.42	236.24	273.93	298.60
		5	0.67	4.32	45.46	120.00	20.89	38.55	43.64	45.46
		10	0.67	10.68	145.14	120.00	45.91	105.80	132.55	145.14
		15	0.67	17.05	204.30	120.00	78.27	154.55	187.03	204.30
		20	0.67	23.41	250.89	120.00	119.47	196.79	231.06	250.89
		25	0.67	29.77	290.74	120.00	158.37	231.38	268.24	290.74
		30	0.67	36.13	324.72	120.00	191.82	260.32	299.60	324.72

¹⁰⁾ Momentum degree of fullness without contribution from channel dead weight

¹¹⁾ Size of the designated system's single load







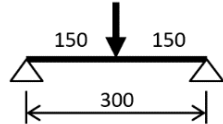

Symbols and designation see Annex D3

Hilti installation channel MQ-41

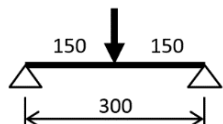
Annex D14

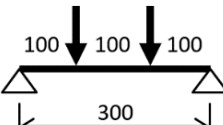
Bending characteristics of the channel at elevated temperatures

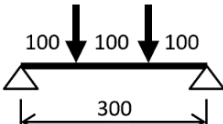
Table D15: Calculation-based deformation at elevated temperatures for installation channel MQ-41-L

System [Dimensions in mm]	Load direction	σ_B	$V^{(10)}$	$F^{(1)}$	$\delta_{t_{max},B}$	$t_{max,B}$	δ_{30}	δ_{60}	δ_{90}	δ_{120}
		[N/mm ²]	-	[N]	[mm]	[min]	[mm]	[mm]	[mm]	[mm]
		5	0.5	137.27	9.99	120.00	9.99	9.99	9.99	9.99
		10	0.5	276.84	11.75	120.00	11.75	11.75	11.75	11.75
		15	0.5	416.42	15.86	63.33	14.16	15.28	63.03	121.65
		20	0.5	555.99	22.39	33.33	18.20	69.87	152.09	152.22
		25	0.5	695.57	18.42	26.67	61.00	151.91	-	-
		30	0.5	835.14	18.09	23.34	-	-	-	-
		5	0.5	137.27	10.15	120.00	10.15	10.15	10.15	10.15
		10	0.5	276.84	12.01	120.00	12.01	12.01	12.01	12.01
		15	0.5	416.42	13.83	55.00	14.77	35.75	152.09	-
		20	0.5	555.99	16.79	28.34	34.83	-	-	-
		25	0.5	695.57	10.20	21.67	55.63	-	-	-
		30	0.5	835.14	8.80	20.01	-	-	-	-
		5	0.67	102.95	10.34	120.00	10.34	10.34	10.34	10.34
		10	0.67	207.63	13.62	120.00	12.86	12.86	12.86	13.62
		15	0.67	312.31	29.55	120.00	16.42	17.49	26.28	29.55
		20	0.67	416.99	38.66	85.00	22.31	28.51	-	-
		25	0.67	521.68	38.73	58.33	30.58	-	-	-
		30	0.67	626.36	43.80	33.33	40.58	-	-	-
		5	0.67	102.95	10.53	120.00	10.53	10.53	10.53	10.53
		10	0.67	207.63	16.24	120.00	13.31	13.31	14.69	16.24
		15	0.67	312.31	31.42	73.33	17.59	22.19	66.63	74.91
		20	0.67	416.99	36.22	40.00	25.58	69.87	-	-
		25	0.67	521.68	29.51	26.67	67.64	-	-	-
		30	0.67	626.36	15.59	21.67	-	-	-	-

¹⁰⁾ Momentum degree of fullness without contribution from channel dead weight

¹¹⁾ Size of the designated system's single load

Symbols and designation see Annex D3

Hilti installation channel MQ-41-L

Annex D15

Bending characteristics of the channel at elevated temperatures

Table D16: Calculation-based deformation at elevated temperatures for installation channel MQ-41-L

System [Dimensions in mm]	Load direction	σ_B	$V^{10)}$	$F^{11)}$	$\delta_{tmax;B}$	$t_{max;B}$	δ_{30}	δ_{60}	δ_{90}	δ_{120}
		[N/mm ²]	-	[N]	[mm]	[min]	[mm]	[mm]	[mm]	[mm]
		5	0.5	79.90	10.95	120.00	10.95	10.95	10.95	10.95
		10	0.5	163.65	26.35	120.00	15.87	15.95	24.25	26.35
		15	0.5	247.39	73.01	111.67	22.77	36.92	63.03	121.65
		20	0.5	331.14	71.90	61.67	35.02	69.87	201.48	220.73
		25	0.5	414.88	74.45	33.33	61.00	196.71	-	-
		30	0.5	498.63	18.72	21.67	-	-	-	-
		5	0.5	79.90	11.04	120.00	11.04	11.04	11.04	11.04
		10	0.5	163.65	26.71	120.00	16.04	16.40	24.60	26.71
		15	0.5	247.39	61.00	88.33	23.10	35.75	226.49	-
		20	0.5	331.14	62.72	53.33	34.83	-	-	-
		25	0.5	414.88	55.64	30.00	55.63	-	-	-
		30	0.5	498.63	52.94	25.00	-	-	-	-
		5	0.80	99.88	12.38	120.00	12.38	12.38	12.38	12.38
		10	0.80	204.56	43.96	93.33	20.52	27.36	42.80	-
		15	0.80	309.24	48.11	40.00	34.56	-	-	-
		20	0.80	413.92	39.52	25.00	-	-	-	-
		25	0.80	518.60	25.70	21.67	-	-	-	-
		30	0.80	623.28	17.19	20.01	-	-	-	-
		5	0.80	99.88	12.57	120.00	12.57	12.57	12.57	12.57
		10	0.80	204.56	43.79	120.00	20.93	27.66	40.11	43.79
		15	0.80	309.24	74.91	120.00	33.22	50.04	66.63	74.91
		20	0.80	413.92	71.07	61.67	50.28	69.87	-	-
		25	0.80	518.60	73.46	33.33	67.64	-	-	-
		30	0.80	623.28	32.67	21.67	-	-	-	-
		5	0.67	33.29	11.78	120.00	11.78	11.78	11.78	11.78
		10	0.67	68.19	35.63	120.00	18.46	21.99	32.61	35.63
		15	0.67	103.08	68.05	120.00	27.9	42.41	59.85	68.05
		20	0.67	137.97	97.11	108.33	42.42	63.00	86.84	132.76
		25	0.67	172.87	92.57	68.33	59.58	83.73	144.49	193.82
		30	0.67	207.76	92.59	43.33	77.67	135.12	199.59	221.04
		5	0.67	33.29	11.90	120.00	11.90	11.90	11.90	11.90
		10	0.67	68.19	37.75	120.00	18.89	23.36	34.73	37.75
		15	0.67	103.08	84.65	120.00	29.06	46.15	67.36	84.65
		20	0.67	137.97	85.76	71.67	45.24	73.06	177.08	242.63
		25	0.67	172.87	87.88	43.33	67.22	173.43	-	-
		30	0.67	207.76	26.73	21.67	-	-	-	-

¹⁰⁾ Momentum degree of fullness without contribution from channel dead weight

¹¹⁾ Size of the designated system's single load

Symbols and designation see Annex D3

Hilti installation channel MQ-41-L

Annex D16

Bending characteristics of the channel at elevated temperatures

Table D17: Calculation-based deformation at elevated temperatures for installation channel MQ-41-L

System [Dimensions in mm]	Load direction	σ_B [N/mm ²]	$V^{(10)}$ -	$F^{(11)}$ [N]	$\delta_{tmax;B}$ [mm]	$t_{max,B}$ [min]	δ_{30} [mm]	δ_{60} [mm]	δ_{90} [mm]	δ_{120} [mm]
		5	0.5	54.44	12.36	120.00	12.36	12.36	12.36	12.36
		10	0.5	114.26	51.65	120.00	21.98	31.32	47.25	51.65
		15	0.5	174.07	121.65	120.00	35.56	67.76	104.96	121.65
		20	0.5	233.89	141.35	83.33	58.66	111.80	201.48	220.73
		25	0.5	293.71	133.40	50.00	99.30	196.71	-	-
		30	0.5	353.53	30.57	21.67	-	-	-	-
		5	0.5	54.44	12.48	120.00	12.48	12.48	12.48	12.48
		10	0.5	114.26	50.68	120.00	22.27	31.66	46.74	50.68
		15	0.5	174.07	101.13	86.67	35.87	64.12	226.49	-
		20	0.5	233.89	98.67	51.67	56.99	-	-	-
		25	0.5	293.71	93.66	30.00	93.64	-	-	-
		30	0.5	353.53	68.20	23.34	-	-	-	-
		5	0.86	95.27	17.01	120.00	15.30	15.30	16.35	17.01
		10	0.86	199.95	53.87	65.00	31.09	50.12	-	-
		15	0.86	304.63	52.31	28.34	-	-	-	-
		20	0.86	409.31	25.86	21.67	-	-	-	-
		25	0.86	513.99	19.34	20.01	-	-	-	-
		30	0.86	618.67	15.07	18.34	-	-	-	-
		5	0.86	95.27	16.90	120.00	15.55	15.55	16.35	16.90
		10	0.86	199.95	71.55	120.00	31.94	49.35	66.24	71.55
		15	0.86	304.63	102.82	120.00	52.49	75.56	94.61	102.82
		20	0.86	409.31	99.17	63.33	74.46	96.68	-	-
		25	0.86	513.99	99.97	35.00	92.12	-	-	-
		30	0.86	618.67	53.21	21.67	-	-	-	-
		5	0.67	15.88	14.08	120.00	14.08	14.08	14.08	14.08
		10	0.67	33.32	61.97	120.00	26.90	40.45	57.00	61.97
		15	0.67	50.77	99.67	120.00	43.72	68.48	90.07	99.67
		20	0.67	68.22	132.76	120.00	65.24	93.02	118.25	132.76
		25	0.67	85.66	151.80	101.67	86.33	114.31	144.49	193.82
		30	0.67	103.11	145.11	68.33	105.62	135.12	199.59	221.04
		5	0.67	15.88	14.18	120.00	14.18	14.18	14.18	14.18
		10	0.67	33.32	66.15	120.00	27.65	43.13	61.06	66.15
		15	0.67	50.77	112.02	120.00	45.99	74.75	99.34	112.02
		20	0.67	68.22	139.09	88.33	70.40	104.22	177.08	242.63
		25	0.67	85.66	135.37	58.33	95.91	173.43	-	-
		30	0.67	103.11	44.21	21.67	-	-	-	-

¹⁰⁾ Momentum degree of fullness without contribution from channel dead weight

¹¹⁾ Size of the designated system's single load

Symbols and designation see Annex D3

Hilti installation channel MQ-41-L

Annex D17

Bending characteristics of the channel at elevated temperatures

Table D18: Calculation-based deformation at elevated temperatures for installation channel MQ-41-L

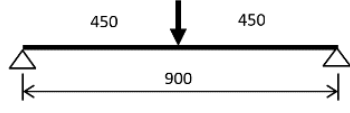
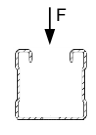
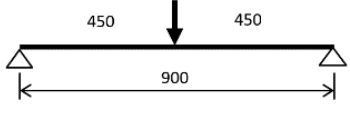
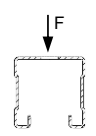
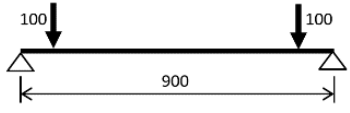
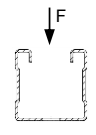
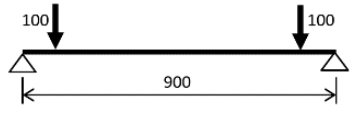
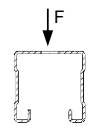
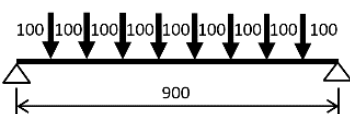
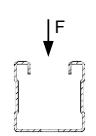
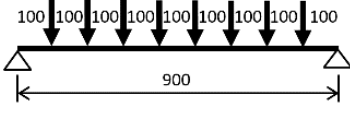
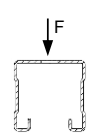
System [Dimensions in mm]	Load direction	σ_B	$V^{10)}$	$F^{11)}$	$\delta_{tmax;B}$	$t_{max;B}$	δ_{30}	δ_{60}	δ_{90}	δ_{120}
		[N/mm ²]	-	[N]	[mm]	[min]	[mm]	[mm]	[mm]	[mm]
		5	0.5	39.61	14.39	120.00	14.39	14.39	14.39	14.39
		10	0.5	86.13	80.97	120.00	30.31	50.69	74.06	80.97
		15	0.5	132.66	171.66	120.00	51.70	101.41	150.76	171.66
		20	0.5	179.18	220.73	120.00	85.69	158.7	201.48	220.73
		25	0.5	225.71	224.25	76.67	139.47	196.71	-	-
		30	0.5	272.23	45.73	21.67	-	-	-	-
		5	0.5	39.61	14.56	120.00	14.56	14.56	14.56	14.56
		10	0.5	86.13	80.27	120.00	30.82	51.52	74.01	80.27
		15	0.5	132.66	140.18	85.00	52.73	96.30	226.49	-
		20	0.5	179.18	137.20	50.00	83.88	-	-	-
		25	0.5	225.71	116.09	28.34	-	-	-	-
		30	0.5	272.23	47.12	21.67	-	-	-	-
		5	0.89	89.12	32.32	120.00	19.05	21.75	30.48	32.32
		10	0.89	193.80	67.26	51.67	46.67	-	-	-
		15	0.89	298.48	21.82	21.67	-	-	-	-
		20	0.89	403.16	18.11	20.01	-	-	-	-
		25	0.89	507.84	15.24	18.34	-	-	-	-
		30	0.89	612.52	25.19	18.34	-	-	-	-
		5	0.89	89.12	26.31	120.00	19.31	21.16	25.47	26.31
		10	0.89	193.80	97.23	120.00	45.31	71.20	90.74	97.23
		15	0.89	298.48	132.36	120.00	72.27	100.77	123.03	132.36
		20	0.89	403.16	128.84	66.67	97.26	123.18	-	-
		25	0.89	507.84	126.62	36.67	116.29	-	-	-
		30	0.89	612.52	118.56	26.67	-	-	-	-
		5	0.67	8.91	20.54	120.00	17.40	17.40	19.78	20.54
		10	0.67	19.38	89.80	120.00	38.11	61.80	83.02	89.80
		15	0.67	29.85	131.42	120.00	62.44	94.92	120.43	131.42
		20	0.67	40.32	164.59	120.00	89.00	122.22	149.97	164.59
		25	0.67	50.78	193.82	120.00	112.32	145.10	175.88	193.82
		30	0.67	61.25	221.04	120.00	132.59	165.24	199.59	221.04
		5	0.67	8.91	20.85	120.00	17.44	17.44	20.10	20.85
		10	0.67	19.38	97.51	120.00	39.44	66.63	90.25	97.51
		15	0.67	29.85	147.48	120.00	66.73	104.99	133.86	147.48
		20	0.67	40.32	197.74	115.00	97.67	138.76	177.08	242.63
		25	0.67	50.78	188.91	70.00	126.55	173.43	-	-
		30	0.67	61.25	31.61	20.01	-	-	-	-

¹⁰⁾ Momentum degree of fullness without contribution from channel dead weight

¹¹⁾ Size of the designated system's single load

Symbols and designation see Annex D3

Hilti installation channel MQ-41-L

Annex D18

Bending characteristics of the channel at elevated temperatures

Table D19: Calculation-based deformation at elevated temperatures for installation channel MQ-41-L

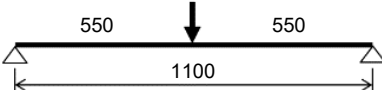
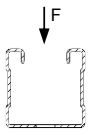
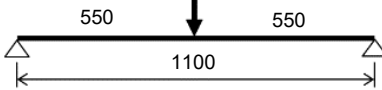
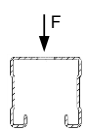
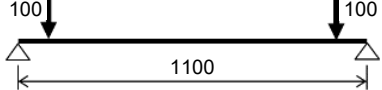
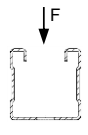
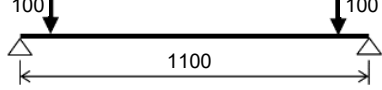
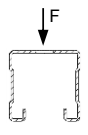
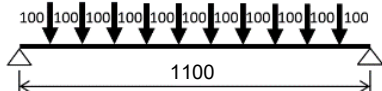
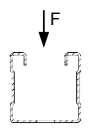
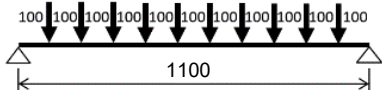
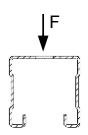
System [Dimensions in mm]	Load-direction	σ_B [N/mm ²]	$V^{(10)}$ -	$F^{(1)}$ [N]	$\delta_{t_{max};B}$ [mm]	$t_{max,B}$ [min]	δ_{30} [mm]	δ_{60} [mm]	δ_{90} [mm]	δ_{120} [mm]
		5	0.5	29.61	17.10	120.00	17.10	17.10	17.10	17.10
		10	0.5	67.68	115.26	120.00	40.78	73.38	104.69	115.26
		15	0.5	105.74	225.59	120.00	70.87	141.32	200.98	225.59
		20	0.5	143.81	284.53	120.00	118.42	210.19	262.44	284.53
		25	0.5	181.87	42.77	21.67	-	-	-	-
		30	0.5	219.94	29.22	20.01	-	-	-	-
		5	0.5	29.61	17.75	120.00	17.36	17.36	17.36	17.75
		10	0.5	67.68	114.21	120.00	41.76	75.23	105.17	114.21
		15	0.5	105.74	180.58	80.00	73.22	131.60	226.49	-
		20	0.5	143.81	174.67	45.00	114.31	-	-	-
		25	0.5	181.87	129.85	26.67	-	-	-	-
		30	0.5	219.94	30.80	20.01	-	-	-	-
		5	0.91	81.43	50.88	120.00	23.53	34.34	47.63	50.88
		10	0.91	186.11	82.29	45.00	64.82	-	-	-
		15	0.91	290.79	30.45	21.67	-	-	-	-
		20	0.91	395.47	25.78	20.01	-	-	-	-
		25	0.91	500.15	20.81	18.34	-	-	-	-
		30	0.91	604.84	17.28	16.67	-	-	-	-
		5	0.91	81.43	36.31	120.00	23.70	29.74	35.12	36.31
		10	0.91	186.11	123.00	120.00	60.30	93.24	115.30	123.00
		15	0.91	290.79	162.89	120.00	92.72	127.1	152.20	162.89
		20	0.91	395.47	159.48	68.33	120.22	151.51	-	-
		25	0.91	500.15	156.33	40.00	141.31	-	-	-
		30	0.91	604.84	150.71	28.34	-	-	-	-
		5	0.67	5.43	32.93	120.00	21.91	25.88	31.77	32.93
		10	0.67	12.41	118.11	120.00	51.85	84.58	109.55	118.11
		15	0.67	19.39	164.18	120.00	82.90	121.75	151.34	164.18
		20	0.67	26.36	197.93	120.00	113.14	151.16	182.27	197.93
		25	0.67	33.34	227.19	120.00	138.33	175.94	209.05	227.19
		30	0.67	40.32	253.24	120.00	159.81	197.23	232.73	253.24
		5	0.67	5.43	32.74	120.00	21.76	25.81	31.58	32.74
		10	0.67	12.41	129.81	120.00	53.93	92.10	120.39	129.81
		15	0.67	19.39	185.84	120.00	89.59	135.91	169.98	185.84
		20	0.67	26.36	242.63	120.00	125.82	174.11	215.99	242.63
		25	0.67	33.34	232.07	71.67	157.76	211.73	-	-
		30	0.67	40.32	44.07	20.01	-	-	-	-

¹⁰⁾ Momentum degree of fullness without contribution from channel dead weight

¹¹⁾ Size of the designated system's single load

Symbols and designation see Annex D3

Hilti installation channel MQ-41-L

Annex D19

Bending characteristics of the channel at elevated temperatures

Table D20: Calculation-based deformation at elevated temperatures for installation channel MQ-41-L

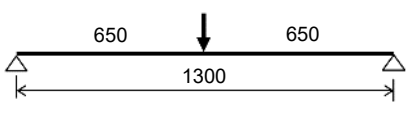
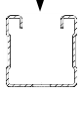
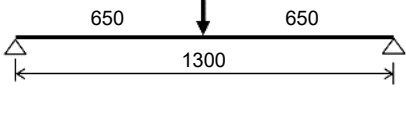
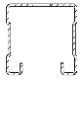
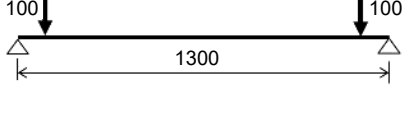
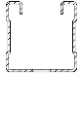
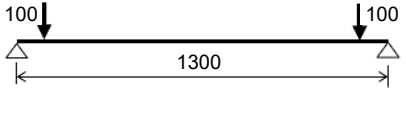
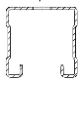
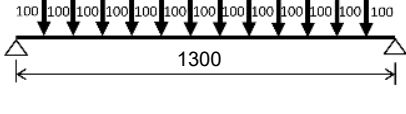
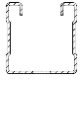
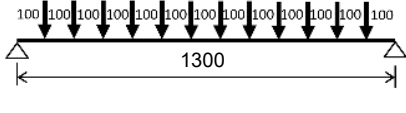
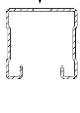
System [Dimensions in mm]	Load-direction	σ_B	$V^{10)}$	$F^{11)}$	$\delta_{tmax;B}$	$t_{max;B}$	δ_{30}	δ_{60}	δ_{90}	δ_{120}
		[N/mm ²]	-	[N]	[mm]	[min]	[mm]	[mm]	[mm]	[mm]
		5	0.5	22.22	24.40	120.00	20.62	20.62	23.18	24.40
		10	0.5	54.43	155.81	120.00	53.44	98.96	138.88	155.81
		15	0.5	86.64	280.67	120.00	92.97	183.12	251.92	280.67
		20	0.5	118.85	351.34	120.00	156.53	262.70	326.19	351.34
		25	0.5	151.06	56.74	21.67	-	-	-	-
		30	0.5	183.27	86.73	21.67	-	-	-	-
		5	0.5	22.22	25.01	120.00	20.68	20.68	23.77	25.01
		10	0.5	54.43	145.27	120.00	54.01	99.39	134.74	145.27
		15	0.5	86.64	239.64	100.00	93.97	162.04	226.49	-
		20	0.5	118.85	227.48	55.00	140.92	-	-	-
		25	0.5	151.06	57.97	21.67	-	-	-	-
		30	0.5	183.27	85.95	21.67	-	-	-	-
		5	0.92	72.21	64.86	120.00	28.97	48.13	61.09	64.86
		10	0.92	176.89	20.07	21.67	-	-	-	-
		15	0.92	281.57	18.16	20.01	-	-	-	-
		20	0.92	386.25	17.42	18.34	-	-	-	-
		25	0.92	490.93	16.95	16.67	-	-	-	-
		30	0.92	595.61	23.07	16.67	-	-	-	-
		5	0.92	72.21	46.99	120.00	28.62	38.89	45.39	46.99
		10	0.92	176.89	150.29	120.00	76.60	116.00	141.07	150.29
		15	0.92	281.57	195.60	120.00	114.30	154.58	183.13	195.60
		20	0.92	386.25	194.74	71.67	144.30	182.05	-	-
		25	0.92	490.93	186.81	41.67	167.60	-	-	-
		30	0.92	595.61	177.80	28.34	-	-	-	-
		5	0.67	3.44	49.33	120.00	27.93	38.58	47.61	49.33
		10	0.67	8.42	146.86	120.00	67.87	108.20	136.41	146.86
		15	0.67	13.41	197.59	120.00	104.63	149.12	182.54	197.59
		20	0.67	18.39	233.73	120.00	137.66	180.52	215.95	233.73
		25	0.67	23.38	263.37	120.00	170.28	213.03	243.60	263.37
		30	0.67	28.36	290.53	120.00	187.73	230.21	268.82	290.53
		5	0.67	3.44	46.77	120.00	27.02	36.96	45.19	46.77
		10	0.67	8.42	159.31	120.00	69.93	117.04	148.59	159.31
		15	0.67	13.41	218.58	120.00	112.04	164.69	202.29	218.58
		20	0.67	18.39	266.02	120.00	151.36	204.02	244.90	266.02
		25	0.67	23.38	268.40	73.33	187.15	246.92	-	-
		30	0.67	28.36	111.20	21.67	-	-	-	-

¹⁰⁾ Momentum degree of fullness without contribution from channel dead weight

¹¹⁾ Size of the designated system's single load







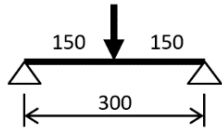

Symbols and designation see Annex D3

Hilti installation channel MQ-41-L

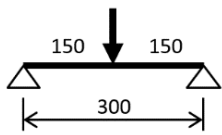
Annex D20

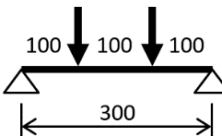
Bending characteristics of the channel at elevated temperatures

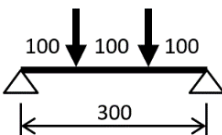
Table D21: Calculation-based deformation at elevated temperatures for installation channel MQ-21.5

System [Dimensions in mm]	Load direction	σ_B	$V^{10)}$	$F^{11)}$	$\delta_{t_{max};B}$	$t_{max,B}$	δ_{30}	δ_{60}	δ_{90}	δ_{120}
		[N/mm ²]	-	[N]	[mm]	[min]	[mm]	[mm]	[mm]	[mm]
		5	0.5	50.93	35.90	120.00	0.78	16.18	35.66	35.90
		10	0.5	103.51	41.97	120.00	2.41	20.30	41.48	41.97
		15	0.5	156.08	50.47	120.00	4.17	25.12	48.98	50.47
		20	0.5	208.66	63.64	120.00	6.62	31.73	59.30	63.64
		25	0.5	261.24	74.39	120.00	9.74	38.50	68.40	74.39
		30	0.5	313.82	83.86	120.00	13.10	44.68	76.57	83.86
		5	0.5	50.93	36.31	120.00	0.93	16.52	36.05	36.31
		10	0.5	103.51	43.42	120.00	2.77	21.19	42.80	43.42
		15	0.5	156.08	54.41	120.00	4.88	27.04	52.11	54.41
		20	0.5	208.66	70.06	120.00	7.75	34.64	64.27	70.06
		25	0.5	261.24	82.33	113.33	11.45	42.65	75.48	120.75
		30	0.5	313.82	81.67	86.67	16.13	50.45	124.59	137.97
		5	0.67	38.2	36.89	120.00	1.17	17.05	36.62	36.89
		10	0.67	77.63	45.83	120.00	3.31	22.57	44.97	45.83
		15	0.67	117.06	58.77	120.00	5.82	29.52	55.58	58.77
		20	0.67	156.5	71.53	120.00	9.62	37.44	66.21	71.53
		25	0.67	195.93	81.04	120.00	13.74	44.38	74.82	81.04
		30	0.67	235.36	89.52	120.00	19.59	50.50	82.16	89.52
		5	0.67	38.2	37.36	120.00	1.35	17.44	37.07	37.36
		10	0.67	77.63	47.56	120.00	3.75	23.70	46.61	47.56
		15	0.67	117.06	62.66	120.00	6.71	31.95	59.10	62.66
		20	0.67	156.5	77.13	120.00	11.11	41.12	71.29	77.13
		25	0.67	195.93	87.84	120.00	15.97	49.17	80.99	87.84
		30	0.67	235.36	96.75	120.00	23.04	56.32	89.43	96.75

¹⁰⁾ Momentum degree of fullness without contribution from channel dead weight

¹¹⁾ Size of the designated system's single load

Symbols and designation see Annex D3

Hilti installation channel MQ-21.5

Annex D21

Bending characteristics of the channel at elevated temperatures

Table D22: Calculation-based deformation at elevated temperatures for installation channel MQ-21.5

System [Dimensions in mm]	Load direction	σ_B	$V^{(10)}$	$F^{(11)}$	$\delta_{t_{max},B}$	$t_{max,B}$	δ_{30}	δ_{60}	δ_{90}	δ_{120}
		[N/mm ²]	-	[N]	[mm]	[min]	[mm]	[mm]	[mm]	[mm]
		5	0.5	28.80	38.56	120	2.27	18.42	38.12	38.56
		10	0.5	60.35	55.26	120	6.78	29.72	54.09	55.26
		15	0.5	91.89	75.41	120	11.65	42.14	71.81	75.41
		20	0.5	123.44	96.70	120	18.46	55.66	89.49	96.70
		25	0.5	154.99	113.39	120	26.10	67.52	103.94	113.39
		30	0.5	186.53	128.30	120	34.30	77.91	116.97	128.3
		5	0.5	28.80	38.97	120	2.42	18.77	38.51	38.97
		10	0.5	60.35	56.87	120	7.15	30.70	55.57	56.87
		15	0.5	91.89	79.20	120	12.45	44.18	74.89	79.20
		20	0.5	123.44	102.39	120	19.77	58.6	93.99	102.39
		25	0.5	154.99	120.75	120	27.99	71.25	109.85	120.75
		30	0.5	186.53	137.97	120	37.11	82.73	124.59	137.97
		5	0.80	36.00	42.70	120	3.89	22.04	42.14	42.70
		10	0.80	75.43	67.72	120	10.62	38.23	65.44	67.72
		15	0.80	114.86	86.05	120	18.48	52.16	81.68	86.05
		20	0.80	154.30	101.46	120	28.53	64.07	95.19	101.46
		25	0.80	193.73	113.54	120	36.97	73.50	106.03	113.54
		30	0.80	233.16	123.53	120	44.64	81.41	115.08	123.53
		5	0.80	36.00	42.99	120	4.01	22.29	42.41	42.99
		10	0.80	75.43	68.61	120	10.95	39.02	66.35	68.61
		15	0.80	114.86	86.95	120	19.09	53.23	82.73	86.95
		20	0.80	154.30	101.46	120	29.44	65.14	95.76	101.46
		25	0.80	193.73	112.58	120	38.16	74.56	106.11	112.58
		30	0.80	233.16	121.50	120	45.82	82.33	114.61	121.50
		5	0.67	12.00	41.09	120	3.29	20.62	40.56	41.09
		10	0.67	25.14	62.83	120	9.02	34.66	60.92	62.83
		15	0.67	38.29	82.20	120	15.38	47.97	77.85	82.20
		20	0.67	51.43	99.29	120	24.04	60.29	92.53	99.29
		25	0.67	64.58	112.50	120	32.26	70.41	104.25	112.50
		30	0.67	77.72	123.34	120	40.24	79.04	114.13	123.34
		5	0.67	12.00	41.45	120	3.43	20.93	40.92	41.45
		10	0.67	25.14	65.08	120	9.53	36.28	63.16	65.08
		15	0.67	38.29	86.83	120	16.61	51.22	82.04	86.83
		20	0.67	51.43	105.54	120	26.14	64.66	98.14	105.54
		25	0.67	64.58	120.13	120	35.15	75.80	111.17	120.13
		30	0.67	77.72	132.38	120	44.49	85.43	122.39	132.38

¹⁰⁾ Momentum degree of fullness without contribution from channel dead weight

¹¹⁾ Size of the designated system's single load

Symbols and designation see Annex D3

Hilti installation channel MQ-21.5

Annex D22

Bending characteristics of the channel at elevated temperatures

Table D23: Calculation-based deformation at elevated temperatures for installation channel MQ-21.5

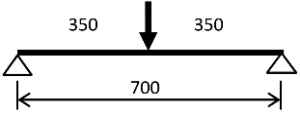
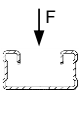
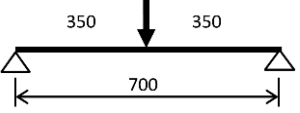
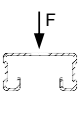
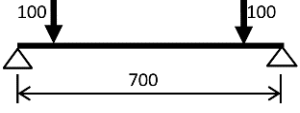
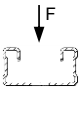
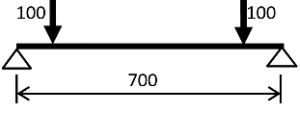
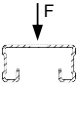
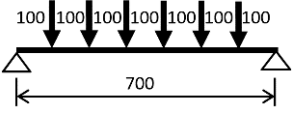
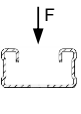
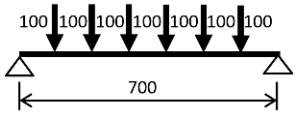
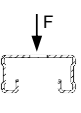
System [Dimensions in mm]	Load direction	σ_B	$V^{(10)}$	$F^{(11)}$	$\delta_{t_{max},B}$	$t_{max,B}$	δ_{30}	δ_{60}	δ_{90}	δ_{120}
		[N/mm ²]	-	[N]	[mm]	[min]	[mm]	[mm]	[mm]	[mm]
		5	0.5	18.69	42.87	120	4.66	22.06	42.11	42.87
		10	0.5	41.22	74.36	120	13.52	43.69	72.19	74.36
		15	0.5	63.75	104.04	120	23.00	63.98	98.56	104.04
		20	0.5	86.29	130.51	120	35.11	82.48	121.10	130.51
		25	0.5	108.82	153.08	120	47.32	98.46	140.66	153.08
		30	0.5	131.35	174.34	120	59.20	112.91	159.25	174.34
		5	0.5	18.69	43.40	120	4.84	22.51	42.62	43.40
		10	0.5	41.22	76.38	120	14.02	44.91	74.00	76.38
		15	0.5	63.75	108.46	120	23.97	66.31	102.11	108.46
		20	0.5	86.29	137.93	120	36.79	86.23	126.89	137.93
		25	0.5	108.82	162.90	120	49.70	103.6	148.57	162.9
		30	0.5	131.35	187.15	120	62.72	119.45	169.73	187.15
		5	0.86	32.70	50.60	120	7.76	28.86	49.62	50.60
		10	0.86	72.14	89.24	120	20.84	55.64	85.67	89.24
		15	0.86	111.57	111.23	120	33.73	72.83	105.44	111.23
		20	0.86	151.00	127.15	120	47.68	86.66	120.00	127.15
		25	0.86	190.44	140.99	120	58.93	98.17	132.62	140.99
		30	0.86	229.87	153.09	120	68.00	107.86	143.64	153.09
		5	0.86	32.70	50.88	120	7.91	29.12	49.88	50.88
		10	0.86	72.14	89.61	120	21.25	56.31	86.14	89.61
		15	0.86	111.57	111.33	120	34.31	73.48	105.72	111.33
		20	0.86	151.00	126.48	120	48.23	86.82	119.71	126.48
		25	0.86	190.44	138.61	120	59.41	97.81	131.17	138.61
		30	0.86	229.87	148.70	120	68.43	106.94	140.90	148.70
		5	0.67	5.45	48.50	120	6.85	26.86	47.57	48.50
		10	0.67	12.02	83.79	120	17.68	50.71	80.55	83.79
		15	0.67	18.59	107.65	120	28.74	68.63	101.88	107.65
		20	0.67	25.17	126.88	120	41.79	83.83	118.85	126.88
		25	0.67	31.74	143.21	120	53.33	96.53	133.38	143.21
		30	0.67	38.31	156.98	120	63.07	107.34	145.85	156.98
		5	0.67	5.45	48.87	120	6.96	27.19	47.94	48.87
		10	0.67	12.02	87.69	120	18.60	53.55	84.37	87.69
		15	0.67	18.59	114.39	120	31.05	73.73	108.10	114.39
		20	0.67	25.17	136.65	120	45.66	90.78	127.59	136.65
		25	0.67	31.74	155.27	120	58.34	105.08	144.28	155.27
		30	0.67	38.31	171.28	120	69.47	117.53	158.93	171.28

¹⁰⁾ Momentum degree of fullness without contribution from channel dead weight

¹¹⁾ Size of the designated system's single load











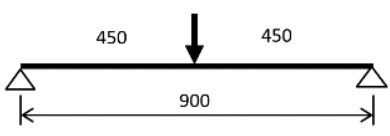

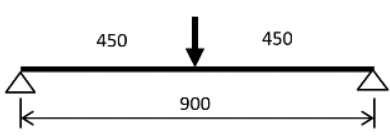
Symbols and designation see Annex D3

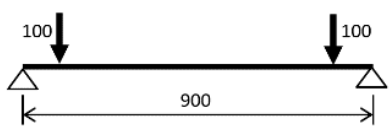
Hilti installation channel MQ-21.5

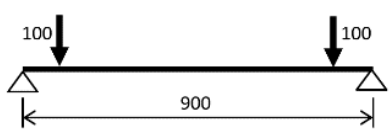
Annex D23

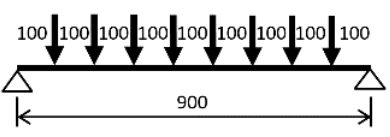
Bending characteristics of the channel at elevated temperatures

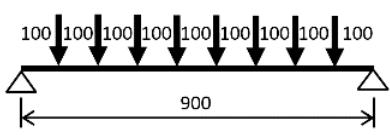
Table D24: Calculation-based deformation at elevated temperatures for installation channel MQ-21.5

System [Dimensions in mm]	Load direction	σ_B	$V^{(10)}$	$F^{(1)}$	$\delta_{t_{max};B}$	$t_{max,B}$	δ_{30}	δ_{60}	δ_{90}	δ_{120}
		[N/mm ²]	-	[N]	[mm]	[min]	[mm]	[mm]	[mm]	[mm]
		5	0.5	12.58	49.30	120	8.15	27.51	48.11	49.30
		10	0.5	30.11	97.00	120	22.72	61.15	93.67	97.00
		15	0.5	47.63	133.93	120	37.51	87.74	126.71	133.93
		20	0.5	65.16	166.00	120	54.52	110.89	154.42	166.00
		25	0.5	82.68	195.66	120	70.96	131.59	180.33	195.66
		30	0.5	100.21	224.81	120	85.93	151.20	206.06	224.81
		5	0.5	12.58	50.15	120	8.43	28.22	48.92	50.15
		10	0.5	30.11	100.38	120	23.50	63.05	96.58	100.38
		15	0.5	47.63	140.68	120	39.17	91.52	132.14	140.68
		20	0.5	65.16	176.76	120	57.49	116.62	162.83	176.76
		25	0.5	82.68	210.43	120	74.93	139.19	191.89	210.43
		30	0.5	100.21	246.64	120	91.48	160.73	222.17	246.64
		5	0.89	28.31	59.71	120	12.57	36.75	58.19	59.71
		10	0.89	67.74	109.76	120	33.00	73.01	105.00	109.76
		15	0.89	107.17	136.23	120	49.91	93.70	128.83	136.23
		20	0.89	146.61	155.10	120	66.20	109.16	146.16	155.10
		25	0.89	186.04	170.24	120	79.48	122.17	160.26	170.24
		30	0.89	225.47	183.31	120	90.35	133.58	172.51	183.31
		5	0.89	28.31	60.01	120	12.81	37.04	58.47	60.01
		10	0.89	67.74	109.90	120	33.61	73.67	105.30	109.90
		15	0.89	107.17	135.71	120	50.61	94.18	128.64	135.71
		20	0.89	146.61	153.73	120	66.66	109.25	145.32	153.73
		25	0.89	186.04	167.79	120	79.68	121.48	158.60	167.79
		30	0.89	225.47	179.25	120	90.29	132.01	169.69	179.25
		5	0.67	2.83	60.12	120	12.26	36.47	58.61	60.12
		10	0.67	6.77	106.43	120	29.17	68.93	101.71	106.43
		15	0.67	10.72	134.39	120	44.68	90.24	126.82	134.39
		20	0.67	14.66	155.11	120	60.88	107.38	145.56	155.11
		25	0.67	18.60	173.28	120	74.92	122.17	161.93	173.28
		30	0.67	22.55	189.33	120	86.68	134.97	176.48	189.33
		5	0.67	2.83	60.06	120	12.17	36.48	58.56	60.06
		10	0.67	6.77	112.27	120	30.64	73.32	107.41	112.27
		15	0.67	10.72	143.63	120	48.42	97.53	135.54	143.63
		20	0.67	14.66	168.45	120	66.87	117.58	157.76	168.45
		25	0.67	18.60	190.50	120	82.58	134.83	177.65	190.50
		30	0.67	22.55	210.11	120	95.88	150.19	195.66	210.11

¹⁰⁾ Momentum degree of fullness without contribution from channel dead weight

¹¹⁾ Size of the designated system's single load

Symbols and designation see Annex D3

Hilti installation channel MQ-21.5

Annex D24

Bending characteristics of the channel at elevated temperatures

Table D25: Calculation-based deformation at elevated temperatures for installation channel MQ-21.5

System [Dimensions in mm]	Load direction	σ_B	$V^{(10)}$	$F^{(11)}$	$\delta_{t_{max},B}$	$t_{max,B}$	δ_{30}	δ_{60}	δ_{90}	δ_{120}
		[N/mm ²]	-	[N]	[mm]	[min]	[mm]	[mm]	[mm]	[mm]
		5	0.5	8.30	58.35	120	12.96	35.24	56.58	58.35
		10	0.5	22.64	121.75	120	34.22	80.87	117.12	121.75
		15	0.5	36.97	165.83	120	54.34	113.17	156.63	165.83
		20	0.5	51.31	203.81	120	75.93	141.19	189.97	203.81
		25	0.5	65.65	241.63	120	96.43	167.46	223.46	241.63
		30	0.5	79.99	279.41	120	114.70	193.19	257.28	279.41
		5	0.5	8.30	59.5	120	13.32	36.14	57.68	59.50
		10	0.5	22.64	126.67	120	35.42	83.71	121.31	126.67
		15	0.5	36.97	173.94	120	56.99	118.18	163.33	173.94
		20	0.5	51.31	216.43	120	80.25	148.38	199.96	216.43
		25	0.5	65.65	259.67	120	101.84	176.81	237.55	259.67
		30	0.5	79.99	306.71	120	121.67	204.71	276.92	306.71
		5	0.91	22.82	69.26	120	18.02	45.01	67.13	69.26
		10	0.91	62.25	130.23	120	46.19	90.30	124.29	130.23
		15	0.91	101.68	161.70	120	66.83	114.64	152.57	161.7
		20	0.91	141.11	184.01	120	84.63	132.70	173.07	184.01
		25	0.91	180.55	201.82	120	99.75	147.39	189.68	201.82
		30	0.91	219.98	216.89	120	112.34	160.17	203.86	216.89
		5	0.91	22.82	68.61	120	17.85	44.48	66.48	68.61
		10	0.91	62.25	130.13	120	46.22	90.65	124.46	130.13
		15	0.91	101.68	160.84	120	67.02	114.88	152.17	160.84
		20	0.91	141.11	182.13	120	84.68	132.58	171.88	182.13
		25	0.91	180.55	198.81	120	99.68	146.72	187.62	198.81
		30	0.91	219.98	212.34	120	111.95	158.70	200.66	212.34
		5	0.67	1.52	76.47	120	19.98	49.77	74.18	76.47
		10	0.67	4.15	129.94	120	43.13	88.32	123.64	129.94
		15	0.67	6.78	161.32	120	62.26	112.41	151.87	161.32
		20	0.67	9.41	184.3	120	80.57	131.16	172.82	184.30
		25	0.67	12.04	203.64	120	96.48	147.46	190.54	203.64
		30	0.67	14.67	221.15	120	110.01	161.97	206.58	221.15
		5	0.67	1.52	75.34	120	19.33	49.06	73.09	75.34
		10	0.67	4.15	137.72	120	45.18	94.29	131.24	137.72
		15	0.67	6.78	173.66	120	67.46	122.15	163.62	173.66
		20	0.67	9.41	201.15	120	88.83	144.74	188.65	201.15
		25	0.67	12.04	225.91	120	107.07	164.77	211.23	225.91
		30	0.67	14.67	248.49	120	122.64	182.8	232.05	248.49

¹⁰⁾ Momentum degree of fullness without contribution from channel dead weight

¹¹⁾ Size of the designated system's single load

Symbols and designation see Annex D3

Hilti installation channel MQ-21.5

Annex D25

Bending characteristics of the channel at elevated temperatures

Table D26: Calculation-based deformation at elevated temperatures for installation channel MQ-21.5

System [Dimensions in mm]	Load direction	σ_B	$V^{10)}$	$F^{11)}$	$\delta_{t_{max},B}$	$t_{max,B}$	δ_{30}	δ_{60}	δ_{90}	δ_{120}
		[N/mm ²]	-	[N]	[mm]	[min]	[mm]	[mm]	[mm]	[mm]
		5	0.5	4.99	70.37	120	19.34	45.57	67.88	70.37
		10	0.5	17.12	148.28	120	47.84	102.40	142.18	148.28
		15	0.5	29.26	199.68	120	73.17	140.21	188.29	199.68
		20	0.5	41.39	244.11	120	98.98	173.42	227.91	244.11
		25	0.5	53.52	290.84	120	123.4	206.14	269.93	290.84
		30	0.5	65.66	337.33	120	145.42	238.51	312.15	337.33
		5	0.5	4.99	69.03	120	18.76	44.41	66.57	69.03
		10	0.5	17.12	148.92	120	47.55	102.68	142.83	148.92
		15	0.5	29.26	201.38	120	73.31	141.42	190.02	201.38
		20	0.5	41.39	245.28	120	99.88	175.08	229.31	245.28
		25	0.5	53.52	292.46	120	124.89	208.20	271.64	292.46
		30	0.5	65.66	338.82	120	147.19	240.38	313.45	338.82
		5	0.92	16.22	78.87	120	23.79	53.24	76.05	78.87
		10	0.92	55.66	151.53	120	59.88	107.99	144.35	151.53
		15	0.92	95.09	188.56	120	84.35	136.35	177.57	188.56
		20	0.92	134.52	214.56	120	103.59	157.21	201.46	214.56
		25	0.92	173.96	235.27	120	120.49	174.14	220.79	235.27
		30	0.92	213.39	252.73	120	134.83	188.67	237.23	252.73
		5	0.92	16.22	78.02	120	23.41	52.52	75.22	78.02
		10	0.92	55.66	152.1	120	59.93	108.82	145.22	152.10
		15	0.92	95.09	188.14	120	84.74	136.95	177.70	188.14
		20	0.92	134.52	212.89	120	103.82	157.33	200.59	212.89
		25	0.92	173.96	232.30	120	120.54	173.71	218.88	232.30
		30	0.92	213.39	248.10	120	134.54	187.49	234.07	248.10
		5	0.67	0.77	96.8	120	30.36	66.32	93.51	96.80
		10	0.67	2.65	154.08	120	59.03	108.42	146.12	154.08
		15	0.67	4.53	188.24	120	80.96	134.78	176.91	188.24
		20	0.67	6.41	213.68	120	100.64	155.24	200.14	213.68
		25	0.67	8.28	234.66	120	117.97	172.76	219.49	234.66
		30	0.67	10.16	253.24	120	132.93	188.58	236.72	253.24
		5	0.67	0.77	91.15	120	27.59	62.56	88.13	91.15
		10	0.67	2.65	160.32	120	59.87	113.66	152.69	160.32
		15	0.67	4.53	200.42	120	84.98	144.67	188.89	200.42
		20	0.67	6.41	230.68	120	108.25	169.16	216.69	230.68
		25	0.67	8.28	256.84	120	128.54	191.19	241.02	256.84
		30	0.67	10.16	281.15	120	146.18	211.36	263.61	281.15

¹⁰⁾ Momentum degree of fullness without contribution from channel dead weight

¹¹⁾ Size of the designated system's single load

Symbols and designation see Annex D3

Hilti installation channel MQ-21.5

Annex D26

Bending characteristics of the channel at elevated temperatures

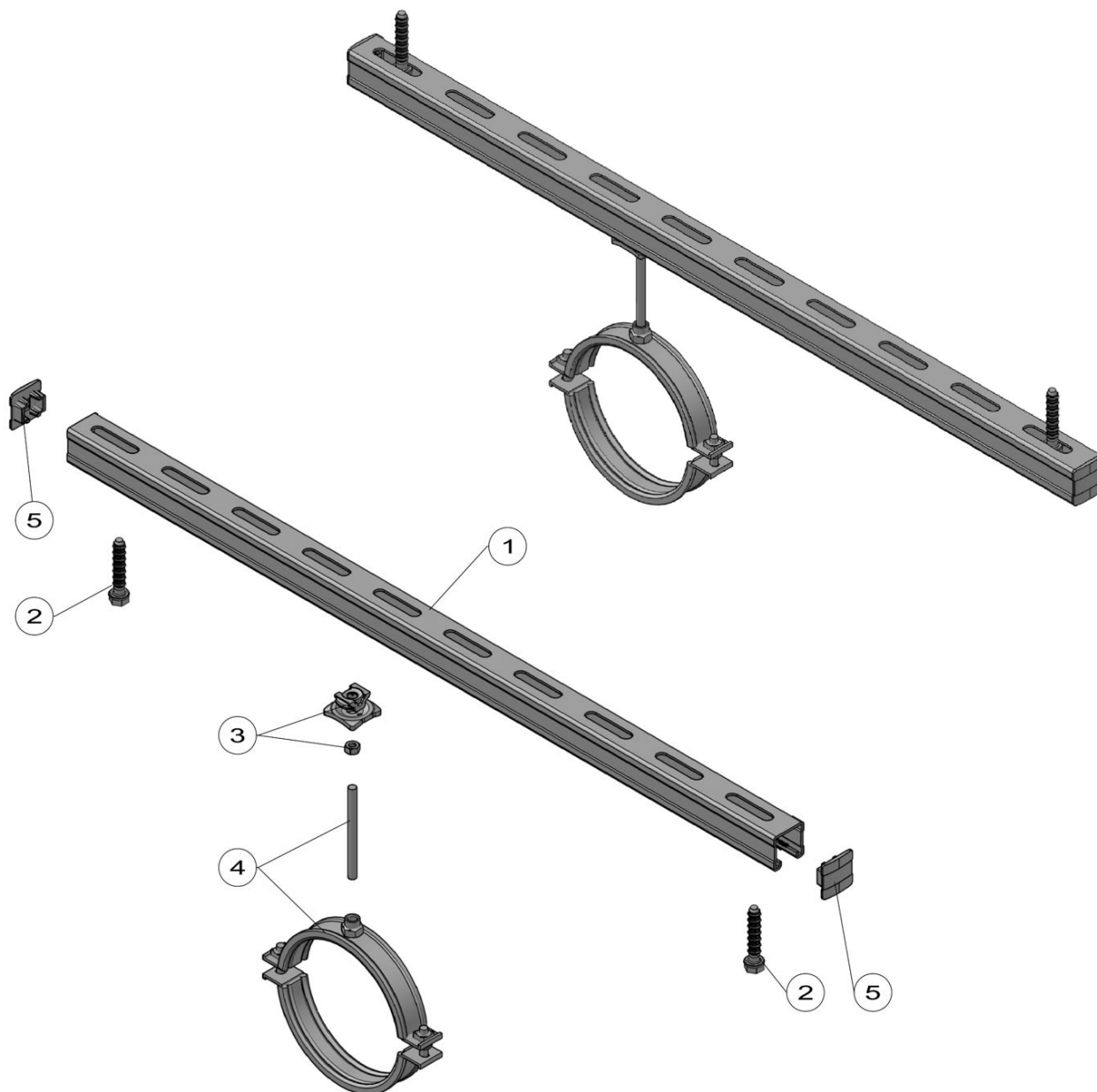

Legend

- 1 MQ-41/3 or MQ-41/3 LL
- 2 Fastener to the substructure
- 3 MQA-B with hexagonal nut
- 4 Pipe ring with threaded rod¹²⁾
- 5 MQZ-E41 end cap

¹²⁾ Number, type and variable pipe ring assignments

Annex

- A1 not an integral part of this ETA
- not an integral part of this ETA
- not an integral part of this ETA
- not an integral part of this ETA

Hilti installation channel MQ-41/3 and Hilti installation channel MQ-41/3 LL

Headrail installation: Fixation in the back of the channel for use at ambient temperature applications

Annex E1
(informative)

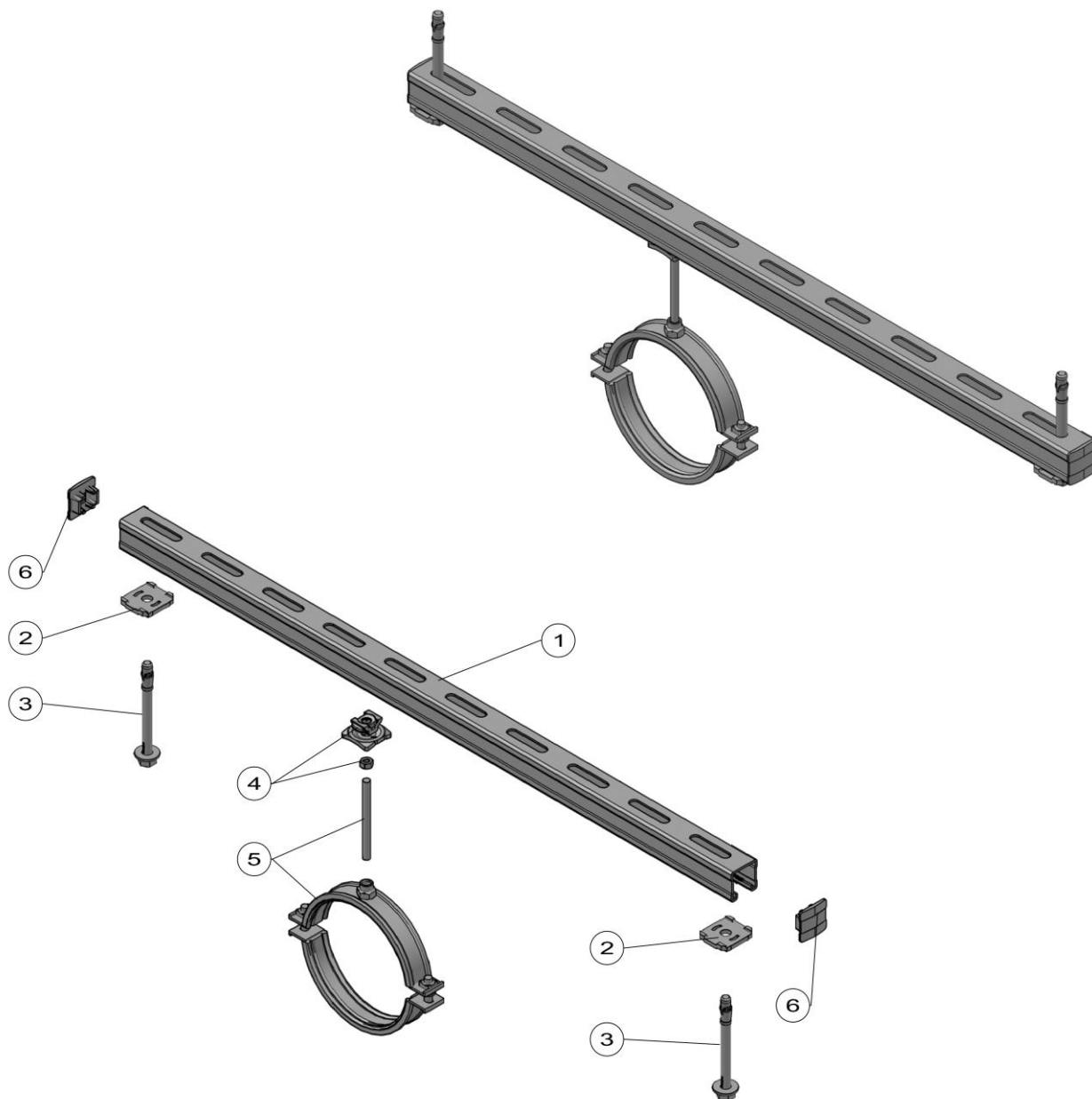

Legend

- 1 MQ-41/3 or MQ-41/3 LL
- 2 MQZ-L drilled plate
- 3 Fastener to the substructure
- 4 MQA-B with hexagonal nut
- 5 Pipe ring with threaded rod¹²⁾
- 6 MQZ-E41 end cap

Annex

- A1 not an integral part of this ETA
- not an integral part of this ETA
- not an integral part of this ETA
- not an integral part of this ETA
- not an integral part of this ETA

¹²⁾ Number, type and variable pipe ring assignments

Hilti installation channel MQ-41/3 and Hilti installation channel MQ-41/3 LL

Headrail installation: Fixation of the channel with MQZ-L drilled plates for use at ambient and elevated temperature applications

Annex E2
(informative)

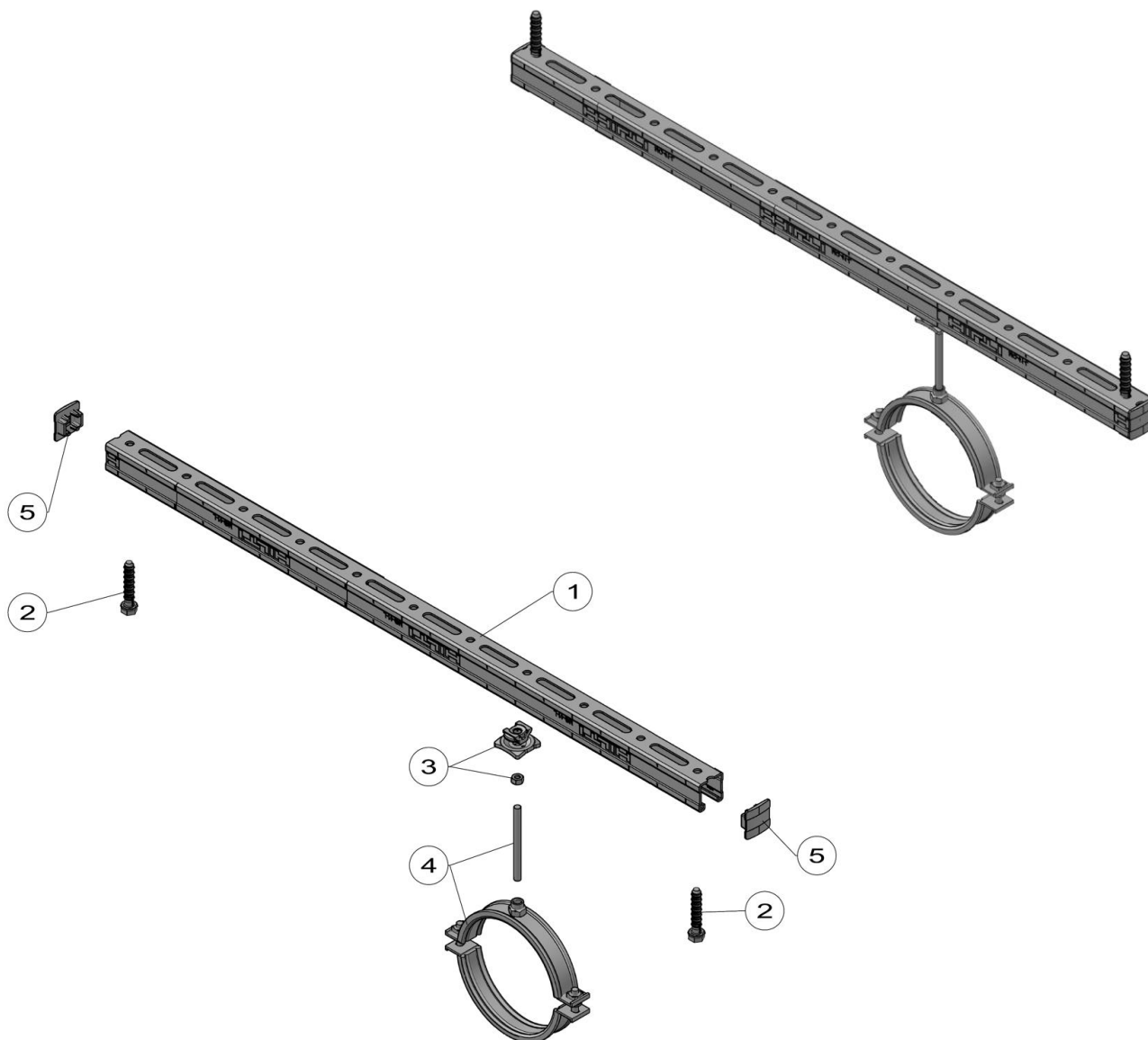

Legend

- 1 MQ-41, MQ-41-L or MQ-21.5
- 2 Fastener to the substructure
- 3 MQA-B with hexagonal nut
- 5 Pipe ring with threaded rod¹²⁾
- 6 MQZ-E41 or MQZ-E21 end cap

¹²⁾ Number, type and variable pipe ring assignments

Annex

- A2 not an integral part of this ETA
- not an integral part of this ETA
- not an integral part of this ETA
- not an integral part of this ETA

Hilti installation channel MQ-21.5, Hilti installation channel MQ-41 and
Hilti installation channel MQ-41-L

Headrail installation: Fixation in the back of the channel for use at ambient and elevated
temperature applications

Annex E3
(informative)

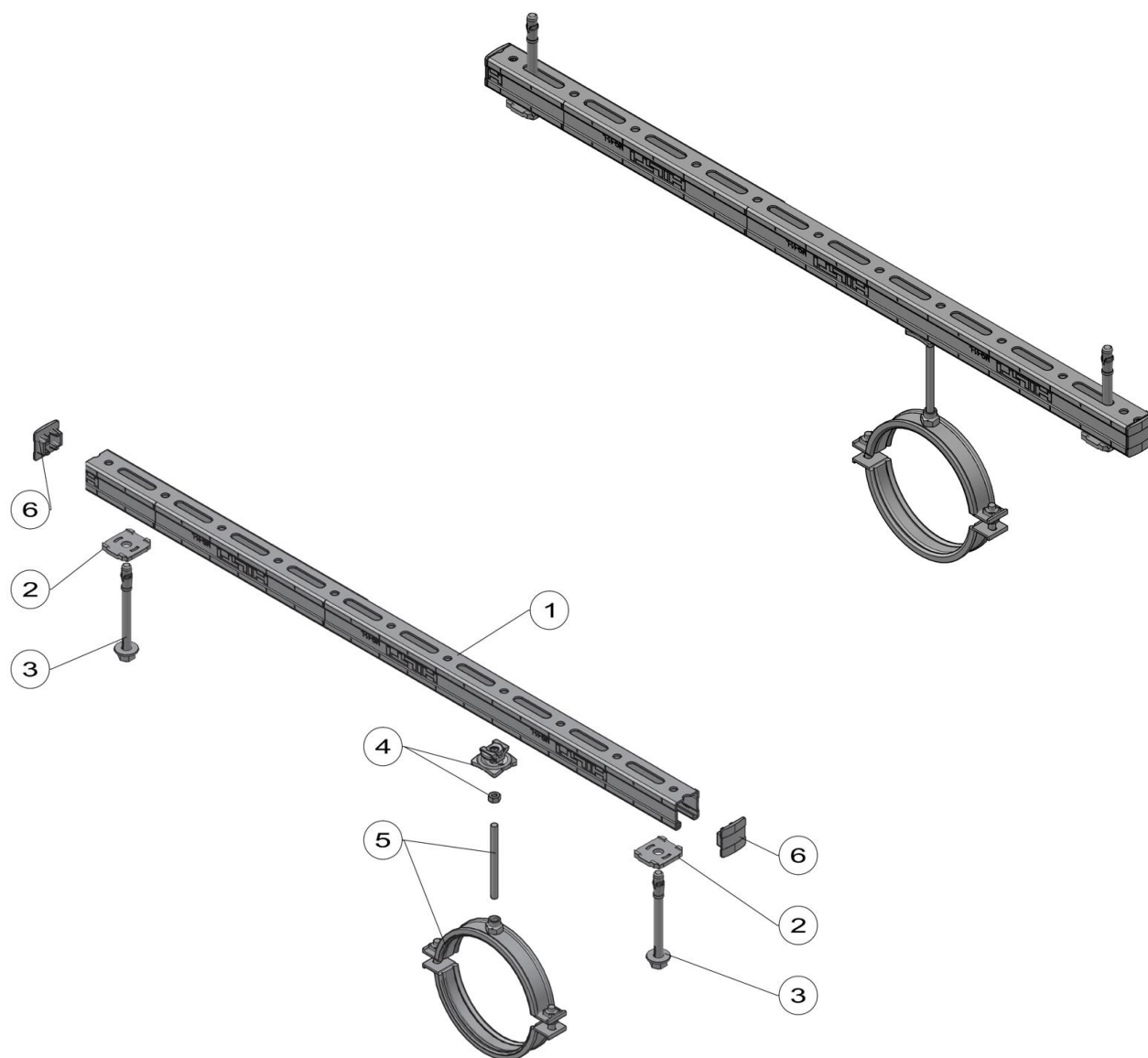

Legend

- 1 MQ-41, MQ-41-L or MQ-21.5
- 2 MQZ-L drilled plate
- 3 Fastener to the substructure
- 4 MQA-B with hexagonal nut
- 5 Pipe ring with threaded rod¹²⁾
- 6 MQZ-E41 or MQZ-E21 end cap

¹²⁾ Number, type and variable pipe ring assignments

Annex

- A2
- not an integral part of this ETA
- not an integral part of this ETA
- not an integral part of this ETA
- not an integral part of this ETA

Hilti installation channel MQ-21.5, Hilti installation channel MQ-41 and
Hilti installation channel MQ-41-L

Headrail installation: Fixation of the channel with MQZ-L drilled plates for use at
ambient and elevated temperature applications

Annex E4
(informative)

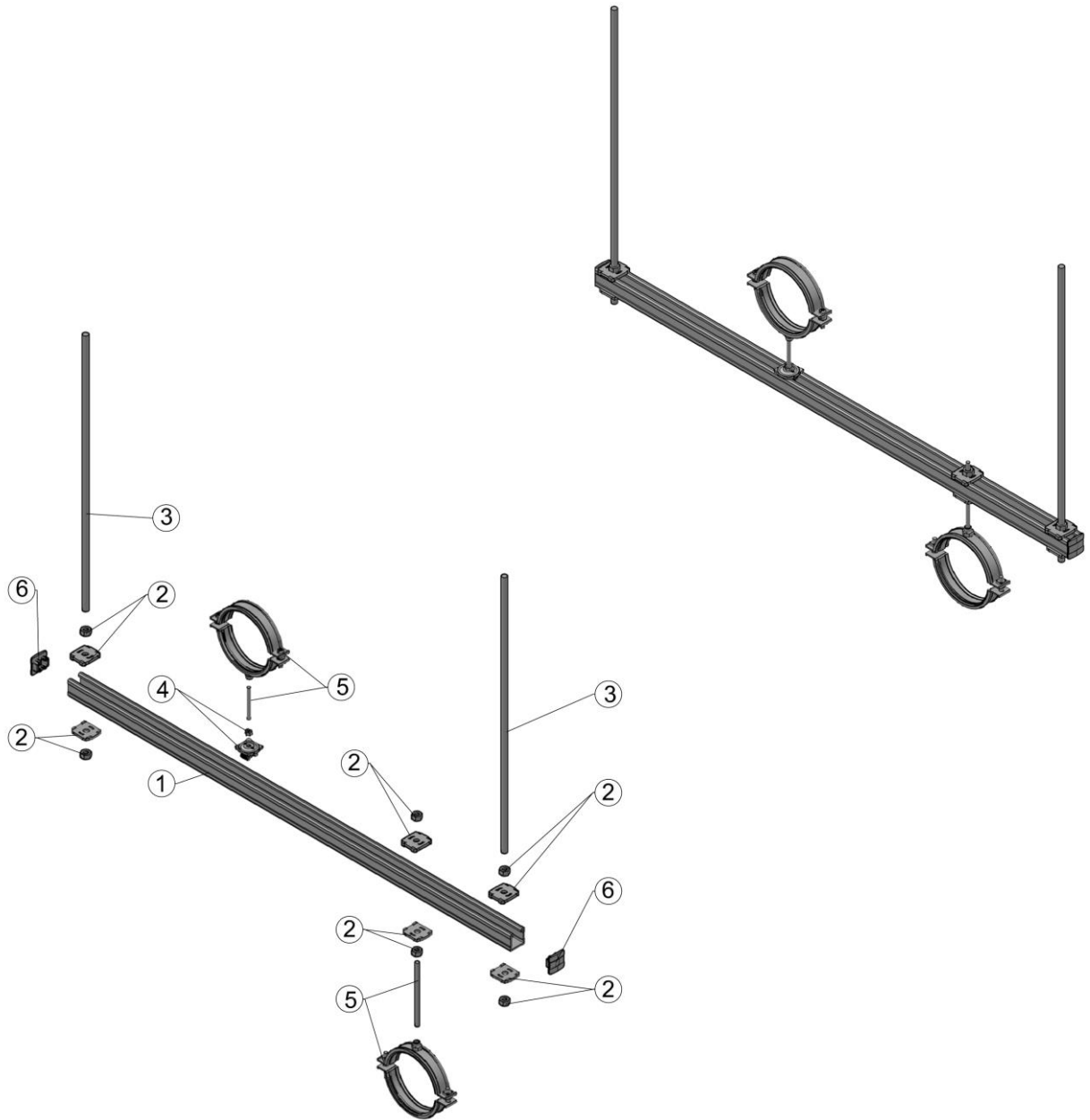

Legend

- 1 MQ-41/3, MQ-41/3 LL, MQ-41, MQ-41-L or MQ-21.5
- 2 MQZ-L with hexagonal nut
- 3 Threaded rod
- 4 MQA-B with hexagonal nut
- 5 Pipe ring with threaded rod¹²⁾
- 6 MQZ-E41 or MQZ-E21 end cap

¹²⁾ Number, type and variable pipe ring assignments

Annex

- A1, A2
- not an integral part of this ETA
- not an integral part of this ETA
- not an integral part of this ETA
- not an integral part of this ETA

Hilti installation channel MQ-41/3, Hilti installation channel MQ-41/3 LL,
Hilti installation channel MQ-21.5, Hilti installation channel MQ-41 and
Hilti installation channel MQ-41-L

Trapeze rod installation with channel opening at the top

Annex E5
(informative)

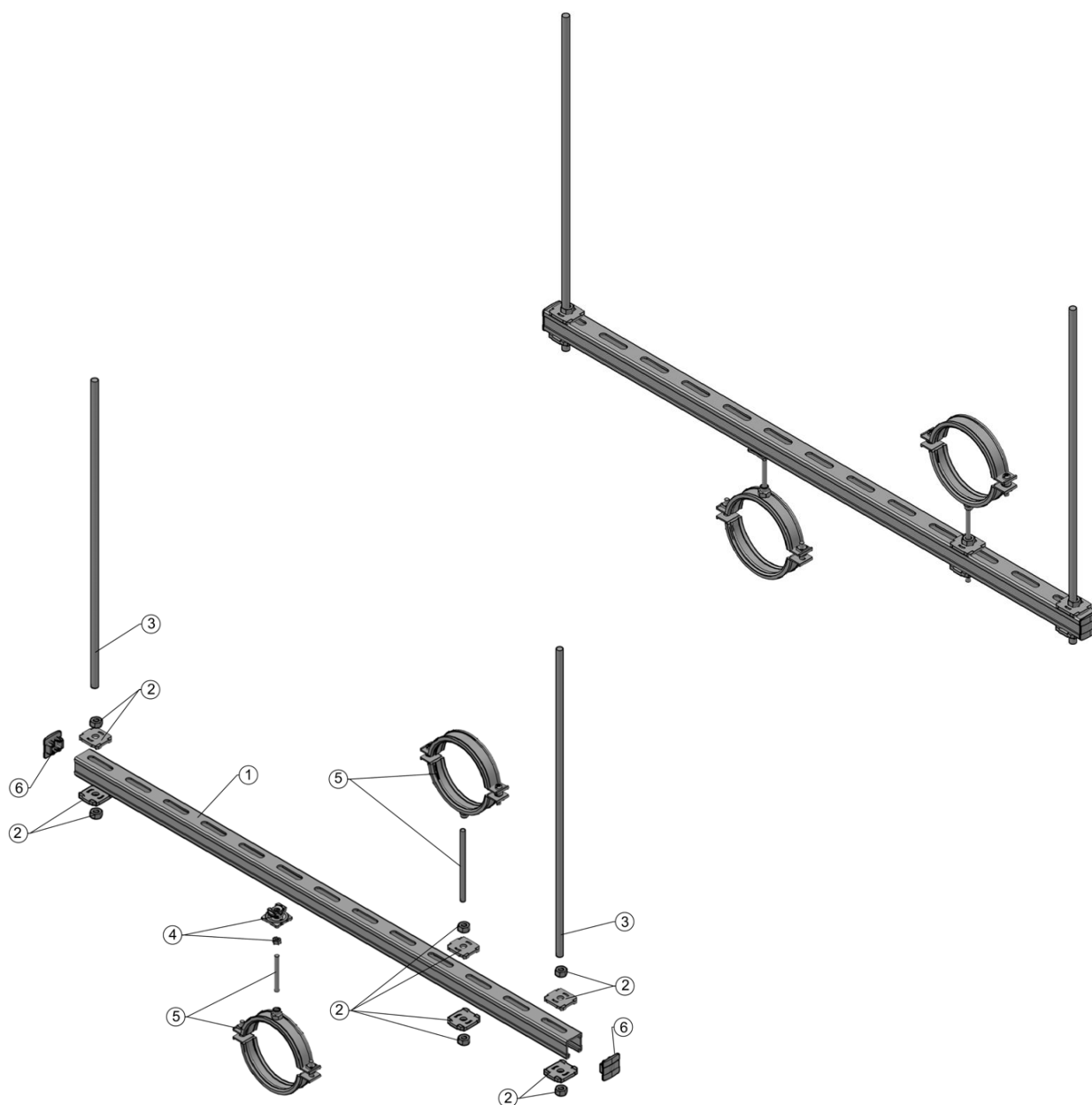

Legend

- 1 MQ-41/3, MQ-41/3 LL or MQ-41, MQ-41-L, MQ-21.5
- 2 MQZ-L with hexagonal nut
- 3 Threaded rod
- 4 MQA-B with hexagonal nut
- 5 Pipe ring with threaded rod¹²⁾
- 6 MQZ-E41 or MQZ-E21 end cap

¹²⁾ Number, type and variable pipe ring assignments

Annex

- A1, A2 not an integral part of this ETA
- not an integral part of this ETA
- not an integral part of this ETA
- not an integral part of this ETA

Hilti installation channel MQ-41/3, Hilti installation channel MQ-41/3 LL,
Hilti installation channel MQ-21.5, Hilti installation channel MQ-41 and
Hilti installation channel MQ-41-L

Trapeze rod installation with channel opening underneath

Annex E6
(informative)

English translation prepared by DIBt

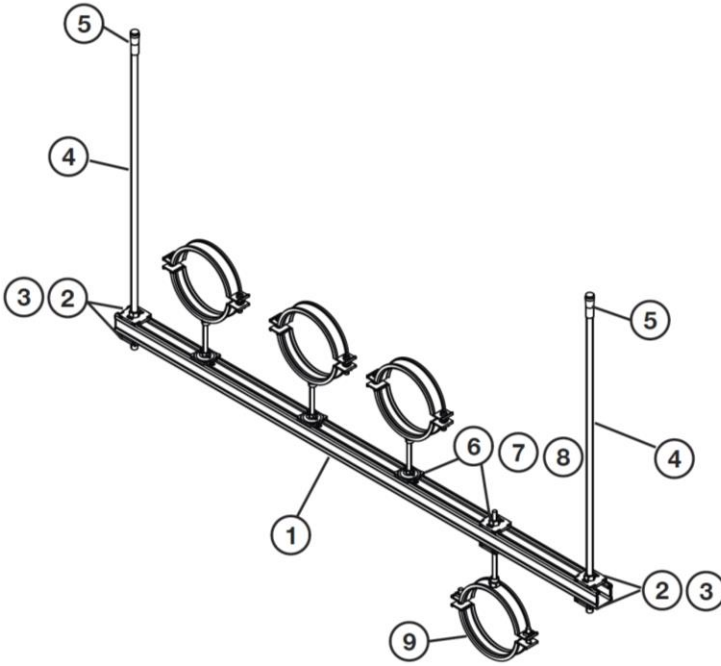

Bill of material / Stückliste				
Part of typical/ Applikationselement	Ref.	Opt.	Item no. / Artikel Nr.	Description / Bezeichnung
Channel / Schiene	1		2184772	MQ-21.5 3m channel*
	1		369596	MQ-41/3 3m channel*
	1		369591	MQ-41 3m channel*
	1		2141965	MQ-41-L 3m channel*
	1		2148102	MQ-41/3-LL 3m channel*
Structure / Aufbau	2	A	2199455	MQZ-L11 drilled plate
	2	B	2199456	MQZ-L13 drilled plate
Fixation / Befestigung	3	A	216466	M10 hexagon nut
	3	B	216467	M12 hexagon nut
	4	A	339795	AM10x1000 4.8 threaded rod**
	4	B	339797	AM12x1000 4.8 threaded rod**
	5	A	376967	HKD M10x40 drop-in anchor
	B	378544	HKD M12x50 drop-in anchor	
Pipe Fixation / Rohrfixierung	6	A	2199452	MQA-M10-B piper saddle
	6	B	2199455	MQZ-L11 drilled plate
	7		216466	M10 hexagon nut
	8		339795	AM10x1000 4.8 threaded rod**
	6	A	2199453	MQA-M12-B piper saddle
	6	B	2199456	MQZ-L13 drilled plate
	7		216467	M12 hexagon nut
	8		339797	AM12x1000 4.8 threaded rod**
M16	6		2199454	MQA-M16-B piper saddle
	7		216468	M16 hexagon nut
	8		216422	AM16x1000 4.8 threaded rod**
Pipe Ring / Rohrschelle	M10/ M12/ M16		20843 - 20898	MP-MI (from 3/8" to 244.5C, with M10, 12, 16)

* other length of the channels also possible / * andere Schienenlängen auch möglich
** Threaded rod available in 1, 2 & 3 meters / Gewindestange erhältlich in 1, 2 & 3 Meter

Assembly Instructions / Montagehinweise

1
Please use the Threaded rod & Anchors either in closed long holes or closed round holes in the channel
Verwendung von Gewindestangen und Dübeln nur durch geschlossene Langlöcher bzw. Rundlöcher der Schiene

2 / 3 / 4

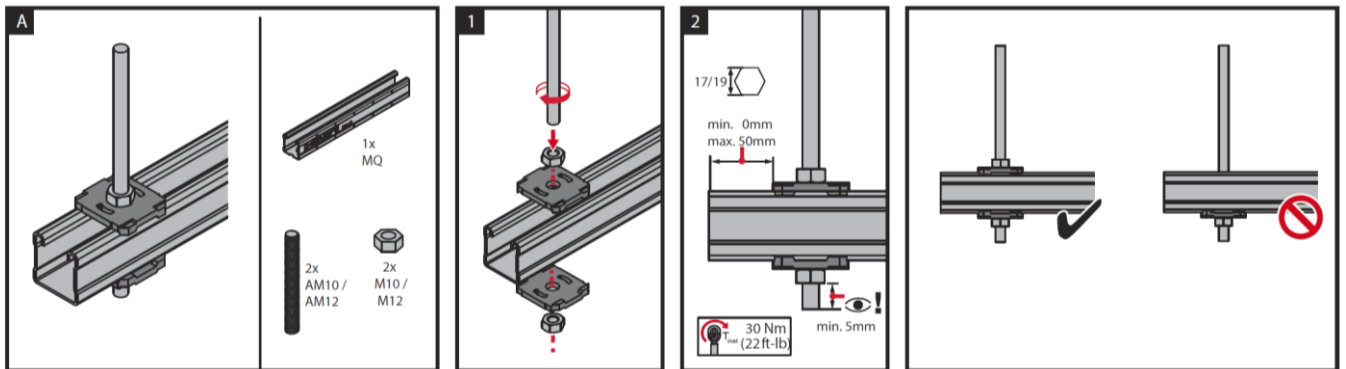

Hilti installation channel MQ-41/3, Hilti installation channel MQ-41/3 LL,
Hilti installation channel MQ-21.5, Hilti installation channel MQ-41 and
Hilti installation channel MQ-41-L

General installation instructions
Trapeze rod with Hilti MQ-41/3, MQ-41/3 LL, MQ-41, MQ-41-L and MQ-21.5

Annex E7
(informative)

English translation prepared by DIBt

6 / 7 / 8

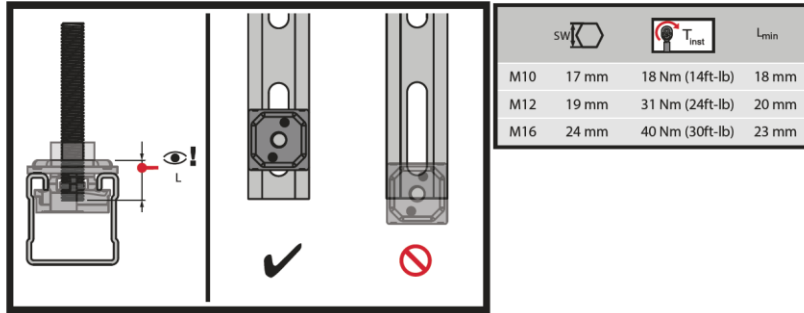
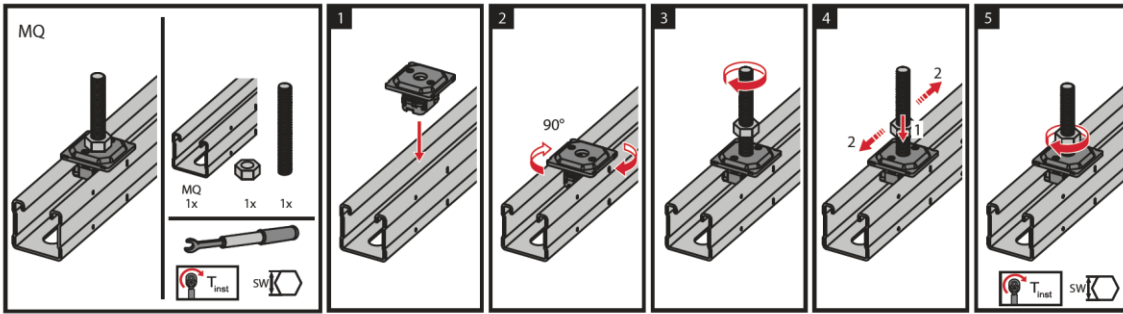

or / oder

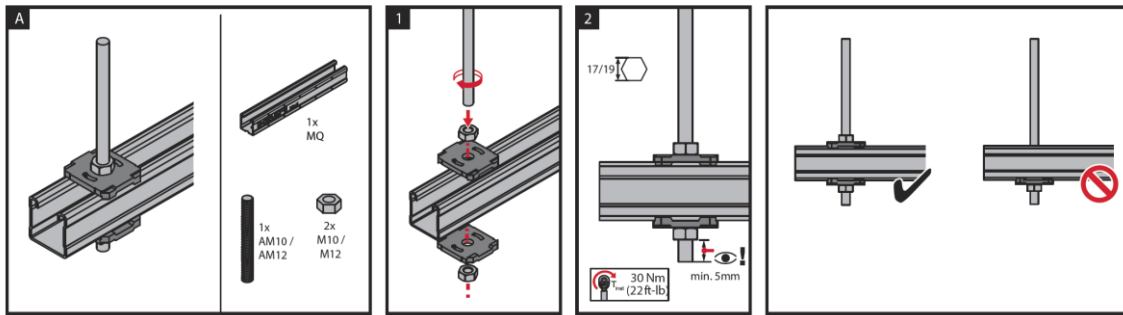

9

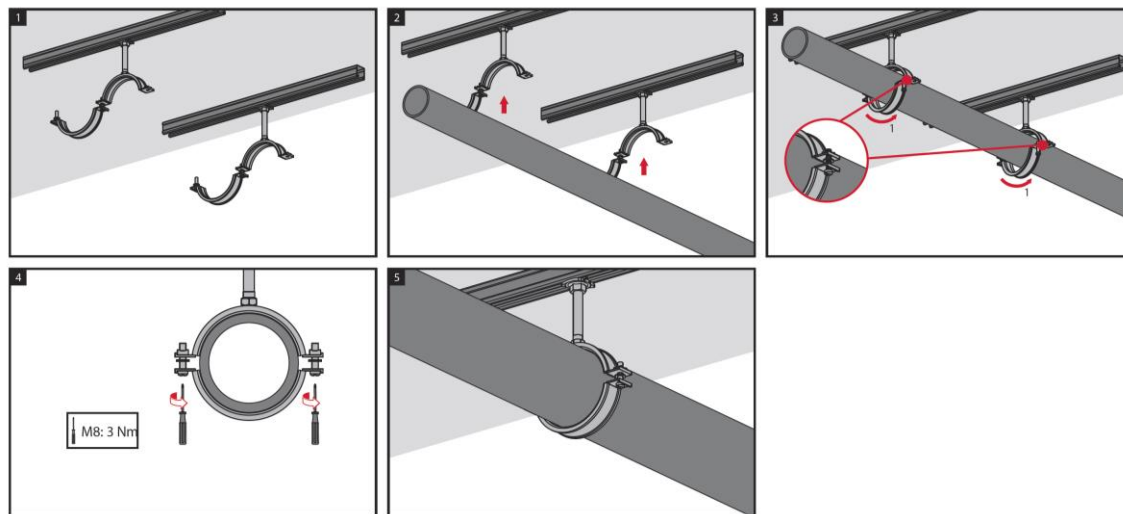

Hilti installation channel MQ-41/3, Hilti installation channel MQ-41/3 LL, Hilti installation channel MQ-21.5, Hilti installation channel MQ-41 and Hilti installation channel MQ-41-L

General installation instructions
Trapeze rod with Hilti MQ-41/3, MQ-41/3 LL, MQ-41, MQ-41-L and MQ-21.5

Annex E8
(informative)

English translation prepared by DIBt

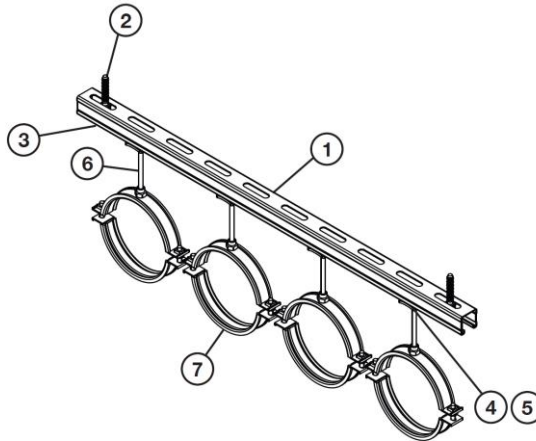

Bill of material for MQ-41/3, MQ-41/3 LL, MQ-41, MQ-41-L:

Bill of material for MQ-21.5:

Bill of material / Stückliste					Bill of material / Stückliste								
Part of typical/ Applikationselement		Ref.	Opt.	Item no. / Artikel Nr.	Description / Bezeichnung	Part of typical/ Applikationselement		Ref.	Opt.	Item no. / Artikel Nr.	Description / Bezeichnung		
Structure / Aufbau	Channel / Schiene	1		369596	MQ-41/3 3m channel*	Structure / Aufbau	Channel / Schiene	1		2184772	MQ-21.5 3m channel*		
		1		2048102	MQ-41/3 LL 3m channel*								
		1		2141965	MQ-41-L 3m channel*								
		1		369591	MQ-41 3m channel*								
Structure / Aufbau	Fixation / Befestigung	2	A	2105715	HST3 M10x130 70/50 + MQZ-L11	Structure / Aufbau	Fixation / Befestigung	2	A	2079797	HST3 M10x110 50/30 + MQZ-L11		
		2	B	2079798	HUS3-H 8x100 50/40/30 + MQZ-L11			2	B	2105714	HUS3-H 8x85 35/25/15 + MQZ-L11		
		3	A	2199455	MQZ-L11 drilled plate			3	A	2199455	MQZ-L11 drilled plate		
Pipe Fixation / Rohrfixierung	M10	4		2199452	MQA-M10-B piping saddle	Pipe Fixation / Rohrfixierung	M10	4		2199452	MQA-M10-B piping saddle		
		5		216466	M10 hexagon nut			5		216466	M10 hexagon nut		
		6		339795	AM10x1000 4.8 threaded rod**			6		339795	AM10x1000 4.8 threaded rod**		
	M12	4		2199453	MQA-M12-B piping saddle		M12	4		2199453	MQA-M12-B piping saddle		
		5		216467	M12 hexagon nut			5		216467	M12 hexagon nut		
		6		339797	AM12x1000 4.8 threaded rod**			6		339797	AM12x1000 4.8 threaded rod**		
	M16	4		2199454	MQA-M16-B piping saddle		M16	4		2199454	MQA-M16-B piping saddle		
		5		216468	M16 hexagon nut			5		216468	M16 hexagon nut		
		6		216422	AM16x1000 4.8 threaded rod**			6		216422	AM16x1000 4.8 threaded rod**		
	Pipe Ring / Rohrschelle	M10/ M12/ M16	7		20843 - 20898		MP-MI (from 3/8" to 244.5C", with M10, 12, 16)	Pipe Ring / Rohrschelle	M10/ M12/ M16	7	A	20843 - 20898	MP-MI (from 3/8" to 244.5C", with M10, 12, 16)

* other lengths of the channels also possible / * andere Schienenlängen auch möglich

** Threaded rod available in 1,2 & 3 meters / ** Gewindestange erhältlich in 1,2 & 3 Meter

MQ-41/3 and MQ-41/3 LL channels can be also mounted on the base material without using MQZ-L11 drilled plates for use at ambient temperatures with the following fasteners through the longhole:
HUS3-H 10x60 5/- (2079911), HST2 M12x105/10 (2107848) or HST3 M12x105 30/10 (2105718).

MQ-21.5, MQ-41 and MQ-41-L channels can be also mounted on the base material without using MQZ-L11 drilled plates for use at ambient and elevated temperatures with the following fasteners through the roundhole:
HUS3-H 8x55 5/- (2079794), HST2 M10x90 /10 (2107847) or HST3 M10x90 30/10 (2105712).

The anchoring of the channels to the base material and the base material itself must be suitable to withstand the resistance values of the channels as well as of the installation systems and that they have a fireproof certificate.

Hilti installation channel MQ-41/3, Hilti installation channel MQ-41/3 LL,
Hilti installation channel MQ-21.5, Hilti installation channel MQ-41 and
Hilti installation channel MQ-41-L

General installation instructions
Headrail with Hilti MQ-41/3, MQ-41/3 LL, MQ-41, MQ-41-L and MQ-21.5

Annex E9
(informative)

English translation prepared by DIBt

Assembly Instructions / Montagehinweise

1

Please use the Threaded rod & Anchors either in closed long holes or closed round holes in the channel
Verwendung von Gewindestangen & Dübeln nur durch geschlossene Langlöcher bzw. Rundlöcher der Schiene

3

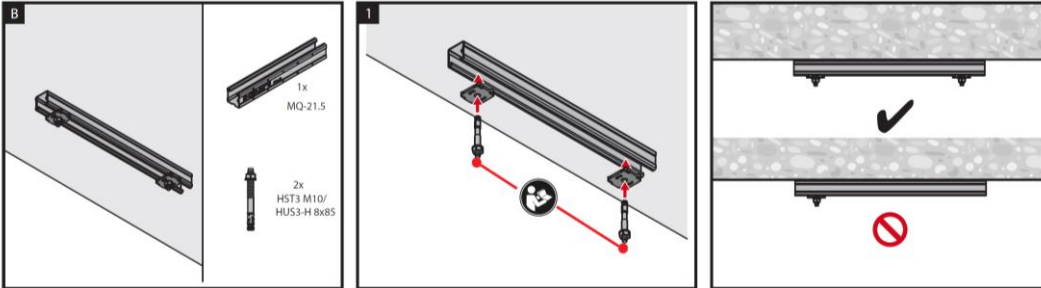

4 / 5 / 6

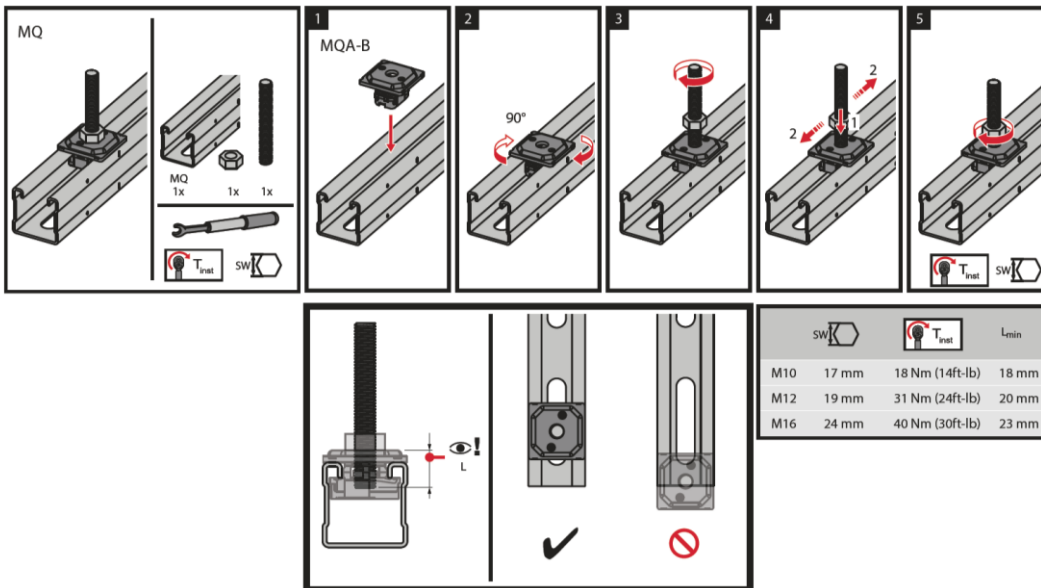

7

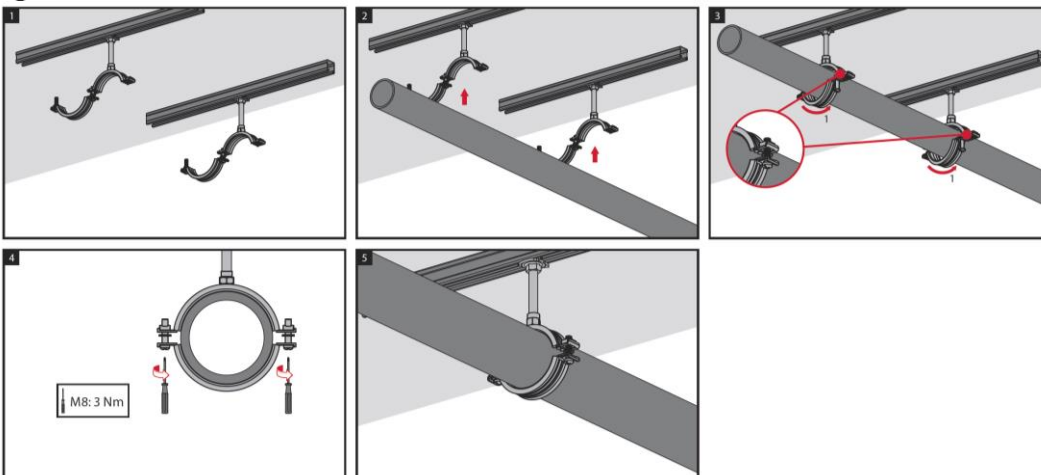

Hilti installation channel MQ-41/3, Hilti installation channel MQ-41/3 LL,
Hilti installation channel MQ-21.5, Hilti installation channel MQ-41 and
Hilti installation channel MQ-41-L

General installation instructions
Headrail with Hilti MQ-41/3, MQ-41/3 LL, MQ-41, MQ-41-L and MQ-21.5

Annex E10
(informative)

Approval body for construction products
and types of construction

Bautechnisches Prüfamt

An institution established by the Federal and
Laender Governments



European Technical Assessment

ETA-18/0130
of 1 June 2018

English translation prepared by DIBt - Original version in German language

General Part

Technical Assessment Body issuing the
European Technical Assessment:

Deutsches Institut für Bautechnik

Trade name of the construction product

Hilti heavy-duty pipe rings MP-MI M10/M12 and
Hilti heavy-duty pipe rings MP-MI M16

Product family
to which the construction product belongs

Products related to installation systems supporting
technical equipment for building services such as pipes,
conduits, ducts and cables

Manufacturer

Hilti AG
Feldkircherstraße 100
9494 Schaan
FÜRSTENTUM LIECHTENSTEIN

Manufacturing plant

L 1000446

This European Technical Assessment
contains

23 pages including 19 annexes which form an integral
part of this assessment

This European Technical Assessment is
issued in accordance with Regulation (EU)
No 305/2011, on the basis of

EAD 280016-00-0602

**European Technical Assessment
ETA-18/0130**

Page 2 of 23 | 1 June 2018

English translation prepared by DIBt

The European Technical Assessment is issued by the Technical Assessment Body in its official language. Translations of this European Technical Assessment in other languages shall fully correspond to the original issued document and shall be identified as such.

Communication of this European Technical Assessment, including transmission by electronic means, shall be in full. However, partial reproduction may only be made with the written consent of the issuing Technical Assessment Body. Any partial reproduction shall be identified as such.

This European Technical Assessment may be withdrawn by the issuing Technical Assessment Body, in particular pursuant to information by the Commission in accordance with Article 25(3) of Regulation (EU) No 305/2011.

Specific Part

1 Technical description of the product

Objects of this European Technical Assessment are Hilti heavy-duty pipe rings MP-MI M10/M12 and Hilti heavy-duty pipe rings MP-MI M16. The MP-MI M10/M12 and MP-MI M16 pipe clamps consist of two profiled steel strips, which are designed to be able to surround a pipe circularly. The clamping strips are connected together by steel screws and are pressed onto the outside of the pipe to be fastened by tightening the screws. The flanges of the upper clamping strips of MP-MI 3/8" G through MP-MI 2" G are incorporated with a thread to tighten the screw plugs. To tighten the screw plugs of MP-MI 68/72 G through MP-MI 244.5 C, nuts M8 are welded to the flanges of the upper clamping strips. Each pipe clamp has a designated clamping range. The top clamping strip features a welded connection head with M10/M12 combi-thread or M16 connection thread version. The clamping strips are fitted with an EDPM profile on the inside to aid structure-borne sound insulation, to balance unevenness and to prevent contact corrosion.

Annex A describes the dimensions and materials of the Hilti heavy-duty pipe rings MP-MI M10/M12 and MP-MI M16. The requirements for performance assessment are given in Annex B.

2 Specification of the intended use in accordance with the applicable European Assessment Document (EAD)

The performance given in Section 3 can only be assumed if the Hilti heavy-duty pipe rings MP-MI M10/M12 and MP-MI M16 are used in compliance with the specifications and under boundary conditions set out in Annexes A to D. The test and assessment methods on which this European Technical Assessment is based lead to an assumption of a working life of the Hilti heavy-duty pipe rings MP-MI M10/M12 and MP-MI M16 of at least 50 years in final use under ambient temperatures in indoor areas. The indications given on the working life cannot be interpreted as a guarantee given by the producer, but are to be regarded only as a means for choosing the right products in relation to the expected economically reasonable working life of the works.

In accordance with the European Assessment Document EAD 280016-00-0602, the product is intended to be used in

- a) installations for the support of sprinkler kits;
- b) installations for the support of other building service elements such as pipes, conduits, ducts and cables.

3 Performance of the product and references to the methods used for its assessment

3.1 Safety in case of fire (BWR 2)

Essential characteristic	Performance
Reaction to fire: Steel parts	Class A1
Reaction to fire: Plastic parts	not relevant for fire growth in accordance with TR021 and therefore do not need to be classified

3.2 Safety and accessibility in use (BWR 4)

Essential characteristic	Performance
Dimensions and materials of Hilti heavy-duty pipe rings MP-MI M10/M12 and MP-MI M16	see Annex A
Characteristics of Hilti heavy-duty pipe rings MP-MI M10/M12 and MP-MI M16 at ambient temperature	see Annex C
Resistance and deformations of Hilti heavy-duty pipe rings MP-MI M10/M12 and MP-MI M16 at elevated temperature	see Annex D

4 Assessment and verification of constancy of performance (AVCP) system applied, with reference to its legal base

In accordance with the European Assessment Document EAD 280016-00-0602, the following legal bases apply:

- In case of intended use a) specified in Section 2:
Decision of the commission N° 1996/577/EC:
System 1 applies for the assessment and verification of constancy of performance (AVCP).
- In case of intended use b) specified in Section 2:
Decision of the commission N° 1999/472/EC:
System 3 applies for the assessment and verification of constancy of performance (AVCP).

5 Technical details necessary for the implementation of the AVCP system, as provided for in the applicable EAD

The technical details necessary for the implementation of the system for the assessment and verification of constancy of performance are laid down in the control plan (confidential part of this European Technical Assessment) deposited at Deutsches Institut für Bautechnik.

Issued in Berlin on 1 June 2018 by Deutsches Institut für Bautechnik

BD Dipl.-Ing. Andreas Kummerow
Head of Department

beglaubigt:
Häßler

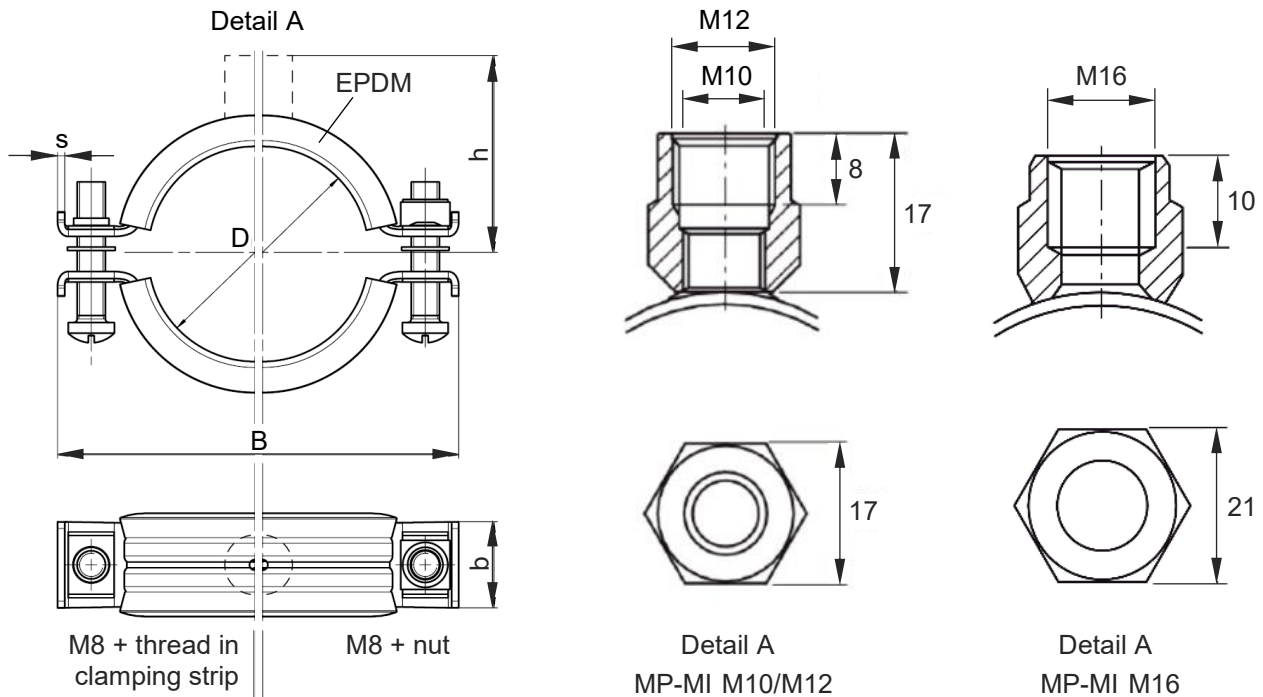

Dimensions in mm

Figure A1: Geometry und dimensions of heavy-duty pipe rings MP-MI

Table A1: Materials of heavy-duty pipe rings MP-MI

Components of pipe rings	Materials
Clamping strip	DD11 in accordance with EN 10111 ¹⁾
Connection head	C10C+U+C in accordance with EN 10263-2, zinc coated
Screw plugs	MP-MI 3/8" G - MP-MI 78/84 G: Strength class 4.8 in accordance with EN ISO 898-1, zinc coated MP-MI 3" G - MP-MI 244.5 C: Strength class 8.8 in accordance with EN ISO 898-1, zinc coated
Nut of screw plug	MP-MI 68/72 G - MP-MI 244.5 C: Square weld nut in accordance with DIN 928-M8-St, zinc coated
Plastic inlays	EPDM

¹⁾ with $235 \text{ N/mm}^2 \leq R_{eL} \leq 340 \text{ N/mm}^2$, Method of deoxidation: fully killed

Hilti heavy-duty pipe rings MP-MI M10/M12 and Hilti heavy-duty pipe rings MP-MI M16

Product description
Dimensions and materials

Annex A1

Table A2.1: Dimensions of heavy-duty pipe rings MP-MI M10/M12

Item number	Designation	D [mm]	B [mm]	b x s [mm]	h [mm]	Closing mechanism
20843	MP-MI 3/8" G	15-19	64	24 x 2.0	33	M8 + thread in clamping strip
20845	MP-MI 1/2" G	20-25	69	24 x 2.0	36	
20847	MP-MI 3/4" G	25-30	75	24 x 2.0	39	
20849	MP-MI 1" G	32-38	83	24 x 2.0	42	
20851	MP-MI 1 1/4" G	40-45	92	24 x 2.0	47	
20853	MP-MI 1 1/2" G	48-54	101	24 x 2.0	50	
20855	MP-MI 54/57 G	54-57	107	24 x 2.0	53	
20857	MP-MI 2" G	57-64	111	24 x 2.0	55	
20860	MP-MI 68/72 G	68-72	123	24 x 2.0	60	M8 + nut
20862	MP-MI 2 1/2" G	70-77	130	24 x 2.0	64	
20865	MP-MI 78/84 G	80-84	139	24 x 2.0	68	
20866	MP-MI 3" G	82-90	144	24 x 2.0	71	
20869	MP-MI 101.6 G	97-103	163	30 x 2.5	78	
20871	MP-MI 4" G	108-114	174	30 x 2.5	84	
20874	MP-MI 117 G	114-119	179	30 x 2.5	86	
20876	MP-MI 125 G	122-127	187	30 x 2.5	90	
20879	MP-MI 133 G	132-137	198	30 x 2.5	95	
20882	MP-MI 5" G	137-142	203	30 x 2.5	98	
20885	MP-MI 159 G	156-162	223	30 x 2.5	107	
20887	MP-MI 6" G	162-168	229	30 x 2.5	110	

Table A2.2: Dimensions of heavy-duty pipe rings MP-MI M16

Item number	Designation	D [mm]	B [mm]	b x s [mm]	h [mm]	Closing mechanism
20872	MP-MI 4" C	108-114	174	30 x 2.5	84	M8 + nut
20880	MP-MI 133 C	132-137	198	30 x 2.5	96	
229087	MP-MI 159 C	156-162	223	30 x 2.5	107	
20888	MP-MI 6" C	162-168	229	30 x 2.5	111	
20890	MP-MI 177.8 C	175-180	244	30 x 3.0	117	
20892	MP-MI 193.7 C	190-200	263	30 x 3.0	127	
20894	MP-MI 212 C	210-219	283	30 x 3.0	136	
20896	MP-MI 219.1 C	217-224	288	30 x 3.0	139	
20898	MP-MI 244.5 C	242-250	314	30 x 3.0	152	

Hilti heavy-duty pipe rings MP-MI M10/M12 and Hilti heavy-duty pipe rings MP-MI M16

Product description
Dimensions

Annex A2

- Hilti heavy-duty pipe rings MP-MI M10/M12 und MP-MI M16 are used to transfer the loads of building services components such as ducts and equipment for sprinkler, water, heating, cooling, ventilation, electrical and other installations. The Hilti heavy-duty pipe rings MP-MI M10/M12 und MP-MI M16 are suitable for undertaking this load-bearing function under the conditions described in Section 2 of this European Technical Assessment.
- The resistance and deformation at ambient and elevated temperatures applies for static and centric actions.
- The resistance and deformation at elevated temperatures are referring to the boundary conditions of the standard temperature / time curve (STTC) in accordance with EN 1363-1.
- The screw plugs for the heavy-duty pipe rings must be tightened consistently with a torque of 3 Nm.
- The performance data for the MP-MI heavy-duty pipe ring results in conjunction with the threaded rods as per Table B1.
- Prior to installation, it must be ensured that the pipe to be inserted, the anchoring of the threaded rods to the base material and the base material itself are suitable to withstand the resistance values of the MP-MI heavy-duty pipe rings and that they have a fireproof certificate.
- The heavy-duty pipe rings must be installed by appropriately qualified personnel and under the supervision of the site manager.

Table B1: Threaded rods for use with heavy-duty pipe rings MP-MI

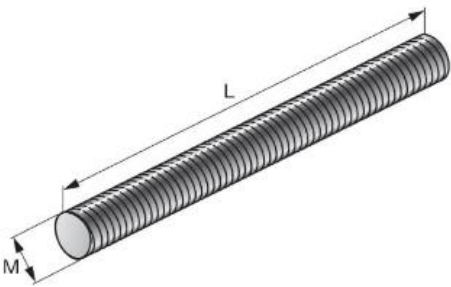
Illustration	Item number	Designation	M thread	L [mm]	Material
	216418	AM10x3000 4.8	M10	3000	Strength class 4.8 in accordance with DIN 976-1, zinc coated
	339796	AM10x2000 4.8	M10	2000	
	339795	AM10x1000 4.8	M10	1000	
	216421	AM12x3000 4.8	M12	3000	
	216420	AM12x2000 4.8	M12	2000	
	339797	AM12x1000 4.8	M12	1000	
	216424	AM16x3000 4.8	M16	3000	
	216423	AM16x2000 4.8	M16	2000	
	216422	AM16x1000 4.8	M16	1000	

Hilti heavy-duty pipe rings MP-MI M10/M12 and Hilti heavy-duty pipe rings MP-MI M16

Requirements for performance assessment

Annex B

Table C1: Characteristic tensile strength at ambient temperature

Item number	Designation	Characteristic tensile strength	Partial safety coefficient ²⁾
		F_{Rk} [kN]	γ_M
20843	MP-MI 3/8" G	8.38	3.33
20845	MP-MI 1/2" G		
20847	MP-MI 3/4" G		
20849	MP-MI 1" G		
20851	MP-MI 1 1/4" G		
20853	MP-MI 1 1/2" G		
20855	MP-MI 54/57 G		
20857	MP-MI 2" G		
20860	MP-MI 68/72 G	11.24	4.46
20862	MP-MI 2 1/2" G		
20865	MP-MI 78/84 G		
20866	MP-MI 3" G	10.07	3.99
20869	MP-MI 101.6 G	12.55	3.73
20871	MP-MI 4" G		
20874	MP-MI 117 G		
20876	MP-MI 125 G		
20879	MP-MI 133 G		
20882	MP-MI 5" G		
20885	MP-MI 159 G		
20887	MP-MI 6" G		
20872	MP-MI 4" C	13.92	4.14
20880	MP-MI 133 C		
229087	MP-MI 159 C		
20888	MP-MI 6" C		
20890	MP-MI 177.8 C	11.62	1.85
20892	MP-MI 193.7 C		
20894	MP-MI 212 C		
20896	MP-MI 219.1 C		
20898	MP-MI 244.5 C		

²⁾ provided that no other national regulations apply

Hilti heavy-duty pipe rings MP-MI M10/M12 and Hilti heavy-duty pipe rings MP-MI M16

Characteristic tensile strength at ambient temperature

Annex C1

Table C2: Service loads and deformations at ambient temperature

Item number	Designation	Service load F_{SLS} [kN]	Associated deformation [mm]
20843	MP-MI 3/8" G	2.67	1.5
20845	MP-MI 1/2" G		
20847	MP-MI 3/4" G		
20849	MP-MI 1" G		
20851	MP-MI 1 1/4" G		
20853	MP-MI 1 1/2" G		
20855	MP-MI 54/57 G		
20857	MP-MI 2" G		
20860	MP-MI 68/72 G	2.16	1.5
20862	MP-MI 2 1/2" G		
20865	MP-MI 78/84 G		
20866	MP-MI 3" G	2.22	1.8
20869	MP-MI 101.6 G	2.43	3.4
20871	MP-MI 4" G		
20874	MP-MI 117 G		
20876	MP-MI 125 G		
20879	MP-MI 133 G		
20882	MP-MI 5" G		
20885	MP-MI 159 G		
20887	MP-MI 6" G		
20872	MP-MI 4" C	2.40	3.4
20880	MP-MI 133 C		
229087	MP-MI 159 C		
20888	MP-MI 6" C		
20890	MP-MI 177.8 C	4.56	5.0
20892	MP-MI 193.7 C		
20894	MP-MI 212 C		
20896	MP-MI 219.1 C		
20898	MP-MI 244.5 C		

Hilti heavy-duty pipe rings MP-MI M10/M12 and Hilti heavy-duty pipe rings MP-MI M16

Service loads and deformations at ambient temperature

Annex C2

English translation prepared by DIBt

Table D1: Resistance of $F_{Rk,t}$ of heavy-duty pipe rings MP-MI 3/8" G - MP-MI 2" G at elevated temperatures after $t = 30, 60, 90$ and 120 minutes

Item number	Designation	Parameter of regression curve $F_{Rk}(t) = c_3 (c_1 + c_2/t)$	$F_{Rk,t}$ [N]			
			$F_{Rk,30}$	$F_{Rk,60}$	$F_{Rk,90}$	$F_{Rk,120}$
20843	MP-MI 3/8" G	$c_1 = 375.852$ $c_2 = 24736.410$ $c_3 = 0.60663$ $18 \text{ min} \leq t \leq 143 \text{ min}$	728	478	395	353
20845	MP-MI 1/2" G					
20847	MP-MI 3/4" G					
20849	MP-MI 1" G					
20851	MP-MI 1 1/4" G					
20853	MP-MI 1 1/2" G					
20855	MP-MI 54/57 G					
20857	MP-MI 2" G					

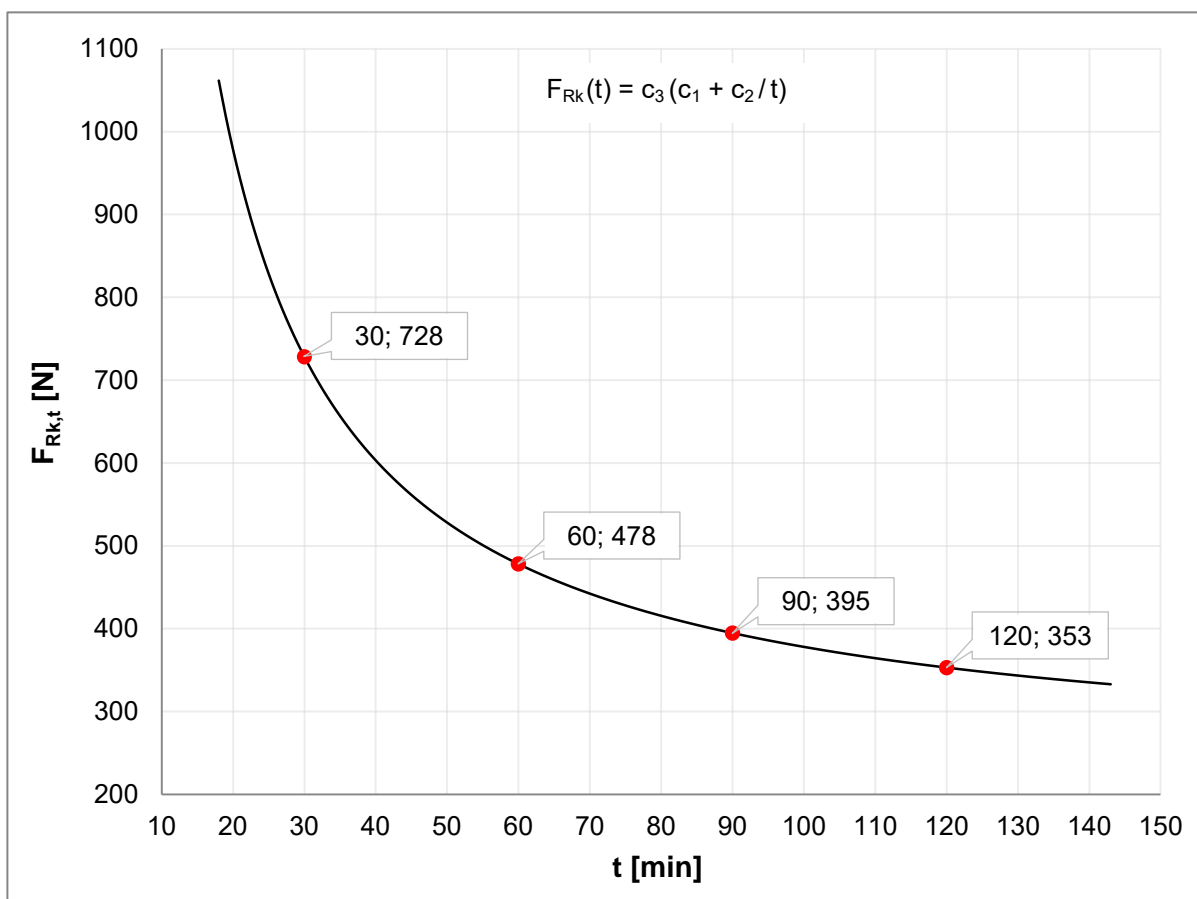

Figure D1: Regression curve according to Table D1

Hilti heavy-duty pipe rings MP-MI M10/M12 and Hilti heavy-duty pipe rings MP-MI M16

Resistance at elevated temperatures of heavy-duty pipe rings
MP-MI 3/8" G - MP-MI 2" G

Annex D1

Table D2: Load displacement function and deformations of heavy-duty pipe rings MP-MI 3/8" G - MP-MI 2" G under elevated temperatures

Item number	Designation	Parameter of regression curve $F_{Rk,30}(\delta) = a_3 (a_1 * \delta^{a_2})$	$F_{Rk,30}(\delta)$ [N]				$\delta_{max,t}$ [mm]		
			$F_{Rk,30}(20)$	$F_{Rk,30}(30)$	$F_{Rk,30}(40)$	$F_{Rk,30}(50)$	$\delta_{max,60}$	$\delta_{max,90}$	$\delta_{max,120}$
20843	MP-MI 3/8" G	$a_1 = 7.0564$ $a_2 = 1.2896$ $a_3 = 0.65031$ $14 \text{ mm} \leq \delta \leq 61 \text{ mm}$	219	369	534	712	72	72	88
20845	MP-MI 1/2" G								
20847	MP-MI 3/4" G								
20849	MP-MI 1" G								
20851	MP-MI 1 1/4" G								
20853	MP-MI 1 1/2" G								
20855	MP-MI 54/57 G								
20857	MP-MI 2" G								

Symbols and designation

- δ Deformation
- $\delta_{max,t}$ Maximum deformation after an exposure time $\leq t$ minutes to elevated temperatures
- $F_{Rk,30}(\delta)$ Load displacement function for an exposure time $t = 30$ minutes to elevated temperatures

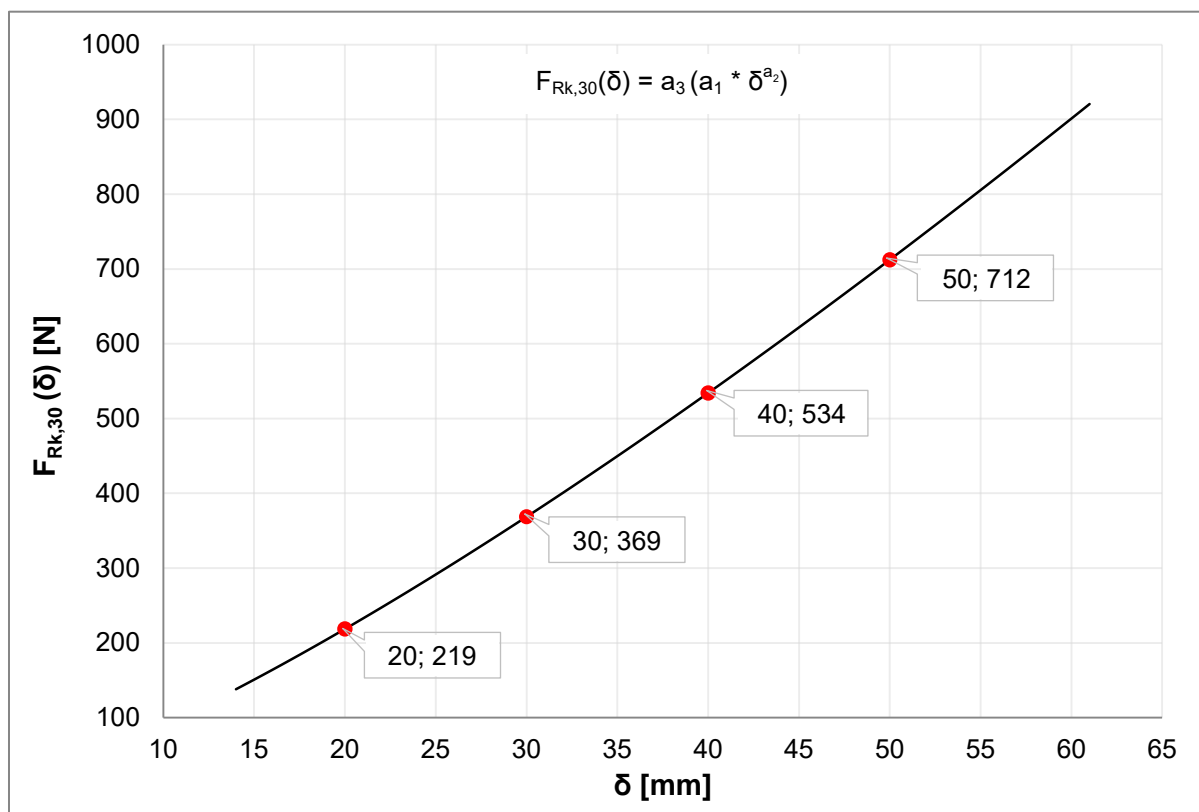

Figure D2: Regression curve according to Table D2

Hilti heavy-duty pipe rings MP-MI M10/M12 and Hilti heavy-duty pipe rings MP-MI M16

Load displacement function and deformations at elevated temperatures of heavy-duty pipe rings MP-MI 3/8" G - MP-MI 2" G

Annex D2

English translation prepared by DIBt

Table D3: Resistance $F_{Rk,t}$ of heavy-duty pipe rings MP-MI 68/72 G - MP-MI 78/84 G at elevated temperatures after $t = 30, 60, 90$ and 120 minutes

Item number	Designation	Parameter of regression curve $F_{Rk}(t) = c_3 (c_1 + c_2/t)$	$F_{Rk,t}$ [N]			
			$F_{Rk,30}$	$F_{Rk,60}$	$F_{Rk,90}$	$F_{Rk,120}$
20860	MP-MI 68/72 G	$c_1 = 343.934$ $c_2 = 29526.426$ $c_3 = 0.675613$ $23 \text{ min} \leq t \leq 142 \text{ min}$	897	565	454	399
20862	MP-MI 2 1/2" G					
20865	MP-MI 78/84 G					

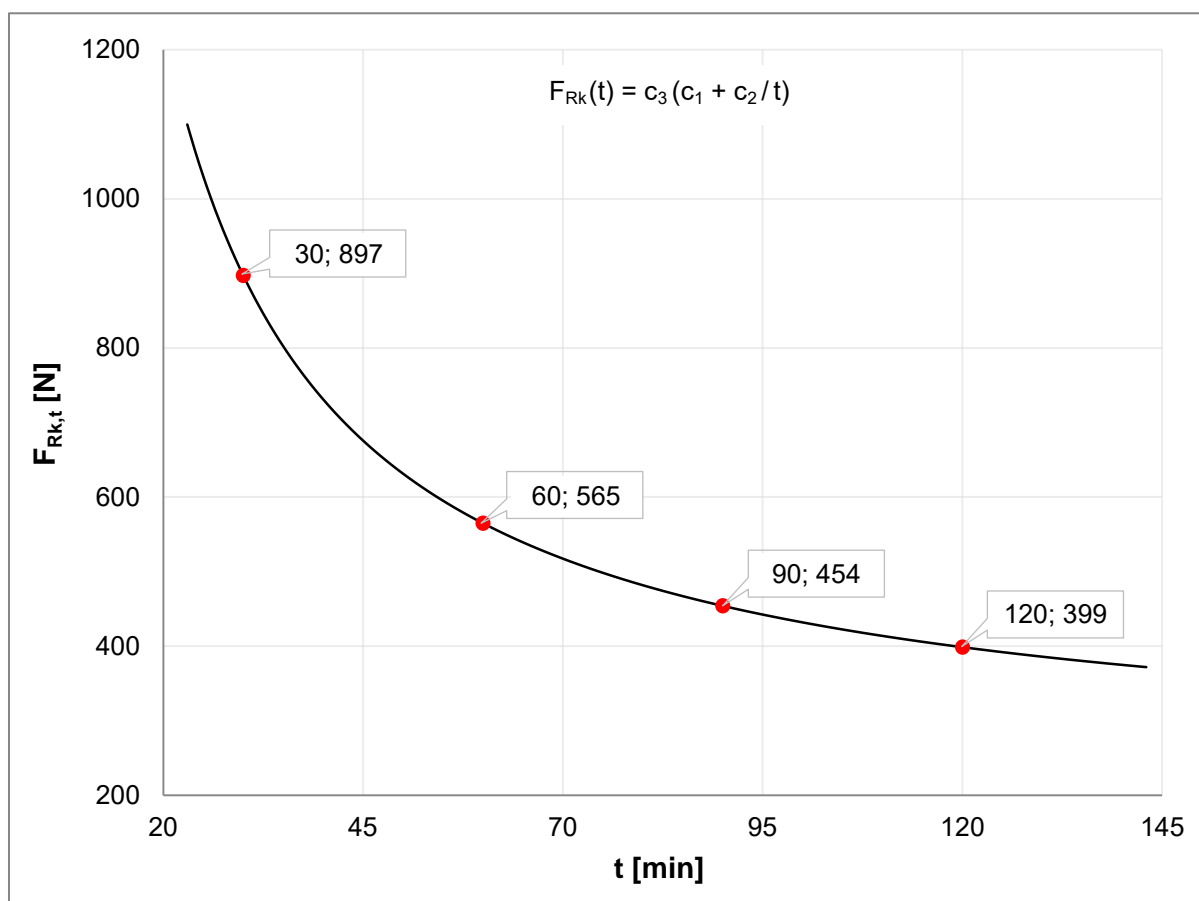

Figure D3: Regression curve according to Table D3

Hilti heavy-duty pipe rings MP-MI M10/M12 and Hilti heavy-duty pipe rings MP-MI M16

Resistance at elevated temperatures of heavy-duty pipe rings
MP-MI 68/72 G - MP-MI 78/84 G

Annex D3

English translation prepared by DIBt

Table D4: Load displacement function and deformations of heavy-duty pipe rings MP-MI 68/72 G - MP-MI 78/84 G under elevated temperatures

Item number	Designation	Parameter of regression curve $F_{Rk,30}(\delta) = a_3 (a_1 * \delta^{a_2})$	$F_{Rk,30}(\delta)$ [N]				$\delta_{max,t}$ [mm]		
			$F_{Rk,30}(20)$	$F_{Rk,30}(30)$	$F_{Rk,30}(40)$	$F_{Rk,30}(50)$	$\delta_{max,60}$	$\delta_{max,90}$	$\delta_{max,120}$
20860	MP-MI 68/72 G	$a_1 = 20.860$ $a_2 = 0.9443$ $a_3 = 0.6584$ $20 \text{ mm} \leq \delta \leq 61 \text{ mm}$	232	341	447	552	88	88	88
20862	MP-MI 2 1/2" G								
20865	MP-MI 78/84 G								

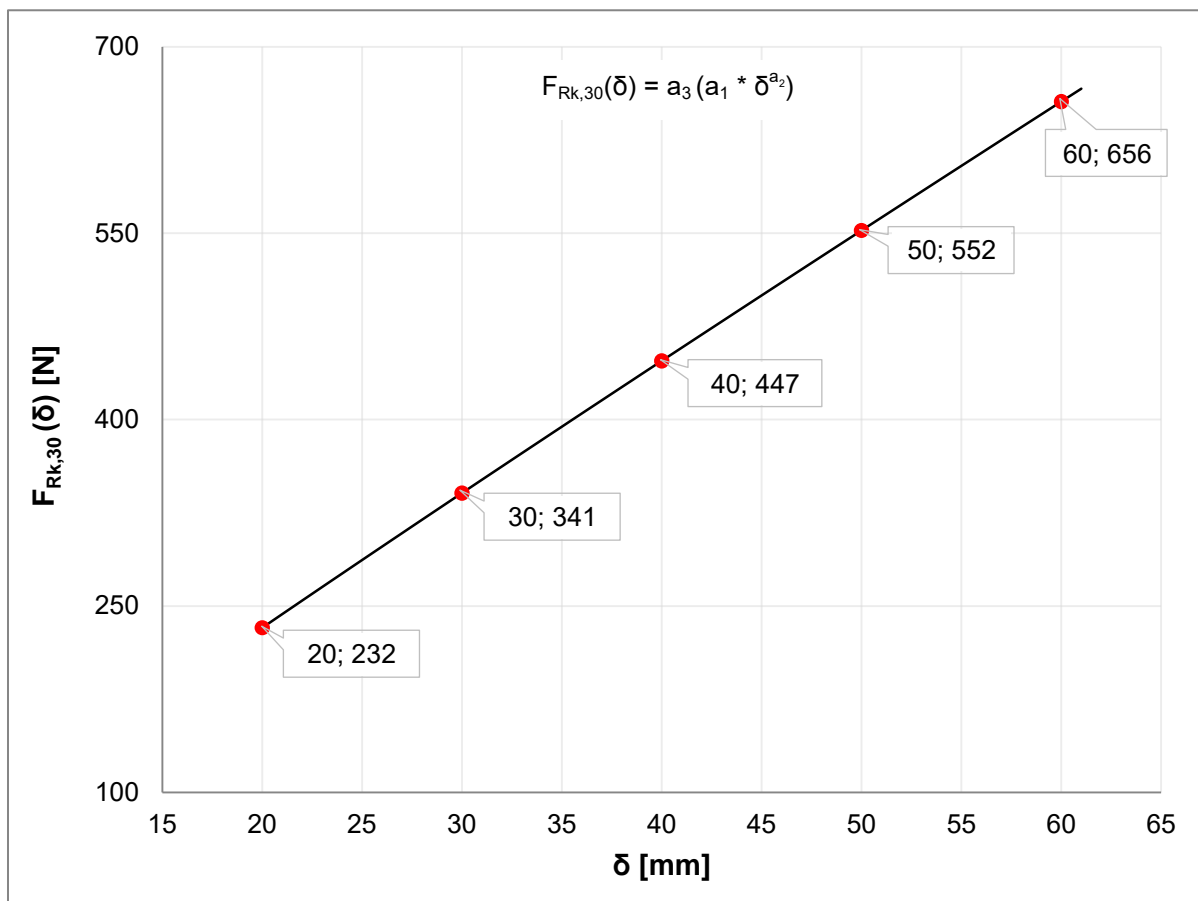

Figure D4: Regression curve according to Table D4

Symbols and designation see Annex D2

Hilti heavy-duty pipe rings MP-MI M10/M12 and Hilti heavy-duty pipe rings MP-MI M16

Load displacement function and deformations at elevated temperatures of heavy-duty pipe rings MP-MI 68/72 G - MP-MI 78/84 G

Annex D4

English translation prepared by DIBt

Table D5: Resistance $F_{Rk,t}$ of heavy-duty pipe rings MP-MI 3" G at elevated temperatures after $t = 30, 60, 90$ and 120 minutes

Item number	Designation	Parameter of regression curve $F_{Rk}(t) = c_3 (c_1 + c_2/t)$	$F_{Rk,t}$ [N]			
			$F_{Rk,30}$	$F_{Rk,60}$	$F_{Rk,90}$	$F_{Rk,120}$
20866	MP-MI 3" G	$c_1 = 491.322$ $c_2 = 16847.386$ $c_3 = 0.7578$ $16 \text{ min} \leq t \leq 131 \text{ min}$	798	585	514	479

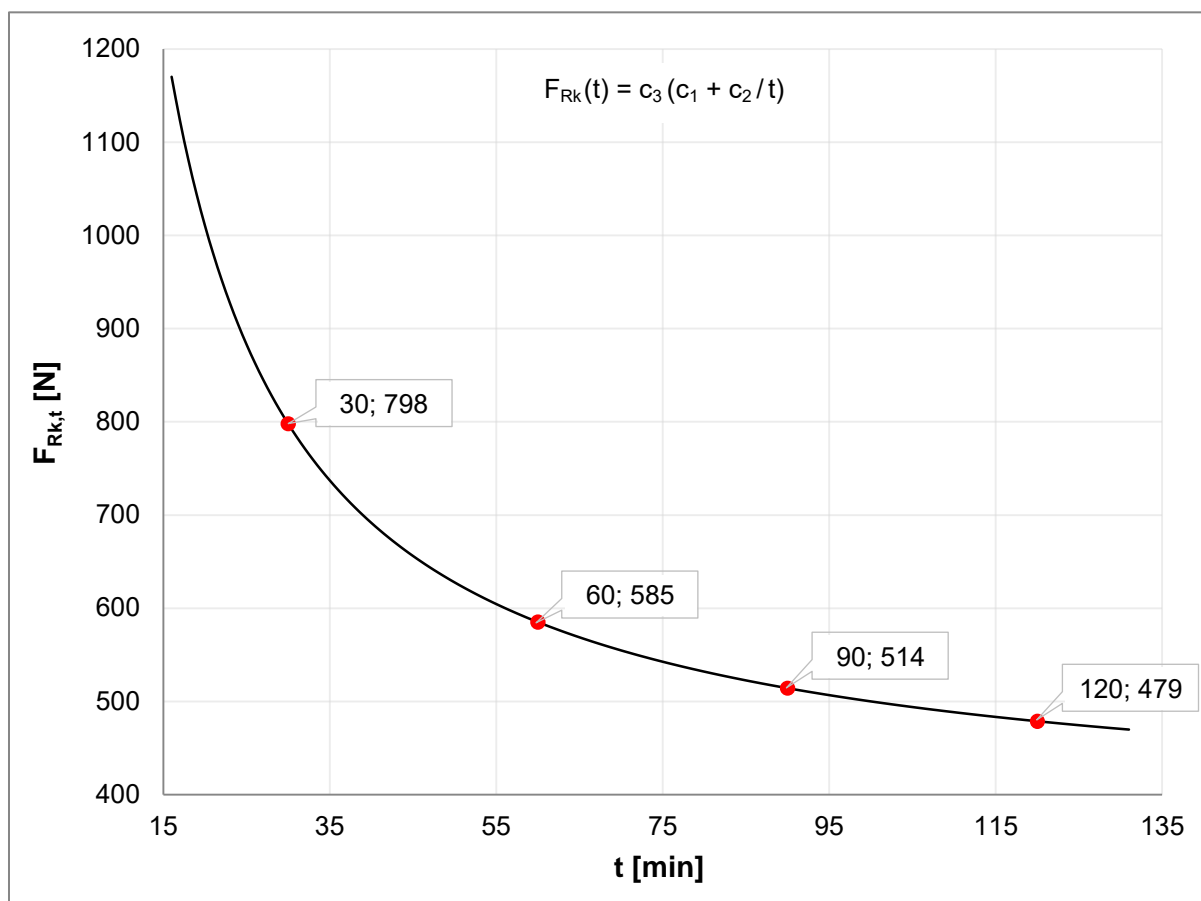

Figure D5: Regression curve according to Table D5

Hilti heavy-duty pipe rings MP-MI M10/M12 and Hilti heavy-duty pipe rings MP-MI M16

Resistance at elevated temperatures of heavy-duty pipe ring MP-MI 3" G

Annex D5

electronic copy of the eta by dibt: eta-18/0130

Table D6: Load displacement function and deformations of heavy-duty pipe rings MP-MI 3" G under elevated temperatures

Item number	Designation	Parameter of regression curve $F_{Rk,30}(\delta) = a_3 (a_1 * \delta^{a_2})$	$F_{Rk,30}(\delta)$ [N]			$\delta_{max,t}$ [mm]		
			$F_{Rk,30}(20)$	$F_{Rk,30}(30)$	$F_{Rk,30}(40)$	$\delta_{max,60}$	$\delta_{max,90}$	$\delta_{max,120}$
20866	MP-MI 3" G	$a_1 = 52.971$ $a_2 = 0.720$ $a_3 = 0.685$ $20 \text{ mm} \leq \delta \leq 46 \text{ mm}$	314	420	517	59	59	59

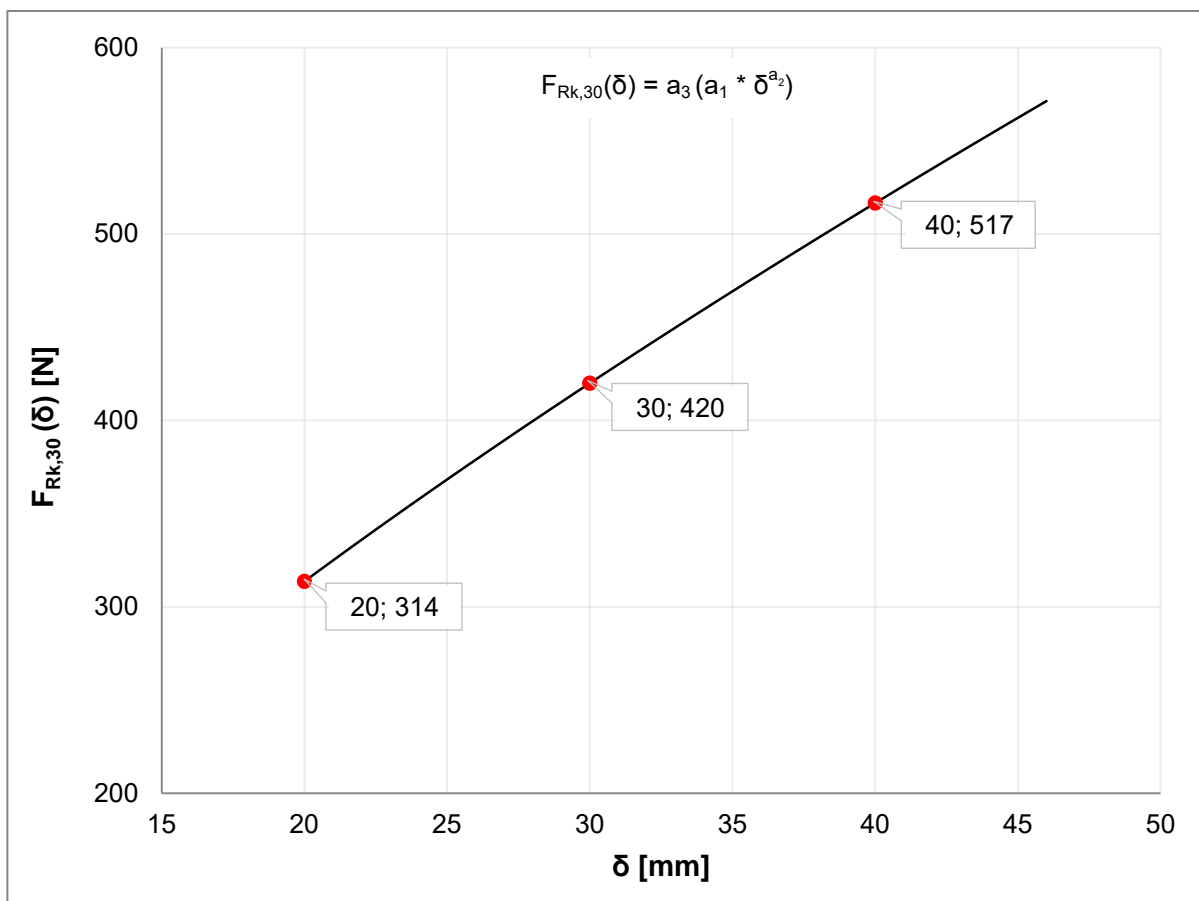

Figure D6: Regression curve according to Table D6

Symbols and designation see Annex D2

Hilti heavy-duty pipe rings MP-MI M10/M12 and Hilti heavy-duty pipe rings MP-MI M16

Load displacement function and deformations at elevated temperatures of heavy-duty pipe ring MP-MI 3" G

Annex D6

English translation prepared by DIBt

Table D7: Resistance $F_{Rk,t}$ of heavy-duty pipe rings MP-MI 101.6 G - MP-MI 6" G at elevated temperatures after $t = 30, 60, 90$ and 120 minutes

Item number	Designation	Parameter of regression curve $F_{Rk}(t) = c_3 (c_1 + c_2/t)$	$F_{Rk,t}$ [N]			
			$F_{Rk,30}$	$F_{Rk,60}$	$F_{Rk,90}$	$F_{Rk,120}$
20869	MP-MI 101.6 G	$c_1 = 489.067$ $c_2 = 31566.912$ $c_3 = 0.8356$ $23 \text{ min} \leq t \leq 147 \text{ min}$	1288	848	702	628
20871	MP-MI 4" G					
20874	MP-MI 117 G					
20876	MP-MI 125 G					
20879	MP-MI 133 G					
20882	MP-MI 5" G					
20885	MP-MI 159 G					
20887	MP-MI 6" G					

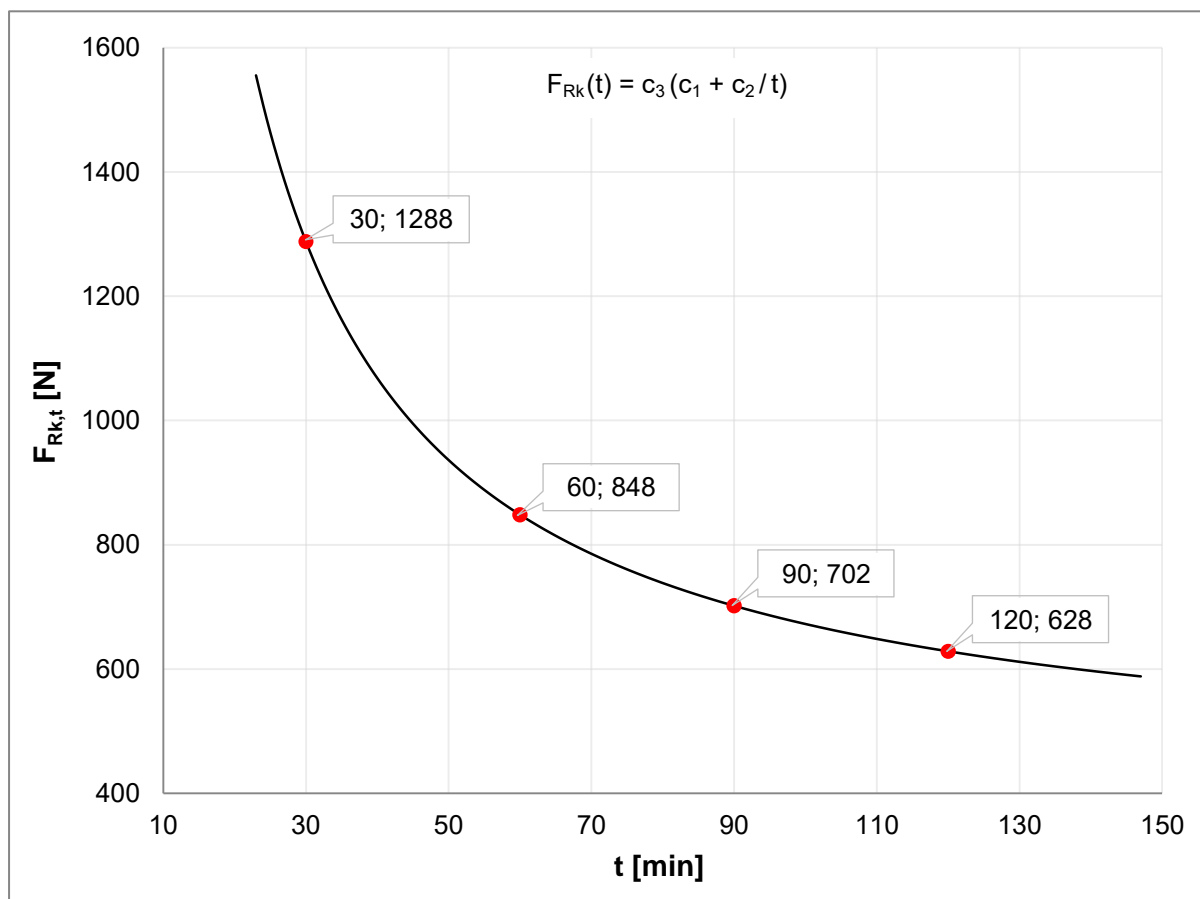

Figure D7: Regression curve according to Table D7

Hilti heavy-duty pipe rings MP-MI M10/M12 and Hilti heavy-duty pipe rings MP-MI M16

Resistance at elevated temperatures of heavy-duty pipe rings
MP-MI 101.6 G - MP-MI 6" G

Annex D7

English translation prepared by DIBt

Table D8: Load displacement function and deformations of heavy-duty pipe rings MP-MI 101.6 G - MP-MI 6" G under elevated temperatures

Item number	Designation	Parameter of regression curve $F_{Rk,30}(\delta) = a_3 (a_1 * \delta^{a_2})$	$F_{Rk,30}(\delta)$ [N]				$\delta_{max,t}$ [mm]		
			$F_{Rk,30}(30)$	$F_{Rk,30}(40)$	$F_{Rk,30}(50)$	$F_{Rk,30}(60)$	$\delta_{max,60}$	$\delta_{max,90}$	$\delta_{max,120}$
20869	MP-MI 101.6 G	$a_1 = 6.060$ $a_2 = 1.2842$ $a_3 = 0.7250$ $30 \text{ mm} \leq \delta \leq 64 \text{ mm}$	347	501	668	844	94	109	111
20871	MP-MI 4" G								
20874	MP-MI 117 G								
20876	MP-MI 125 G								
20879	MP-MI 133 G								
20882	MP-MI 5" G								
20885	MP-MI 159 G								
20887	MP-MI 6" G								

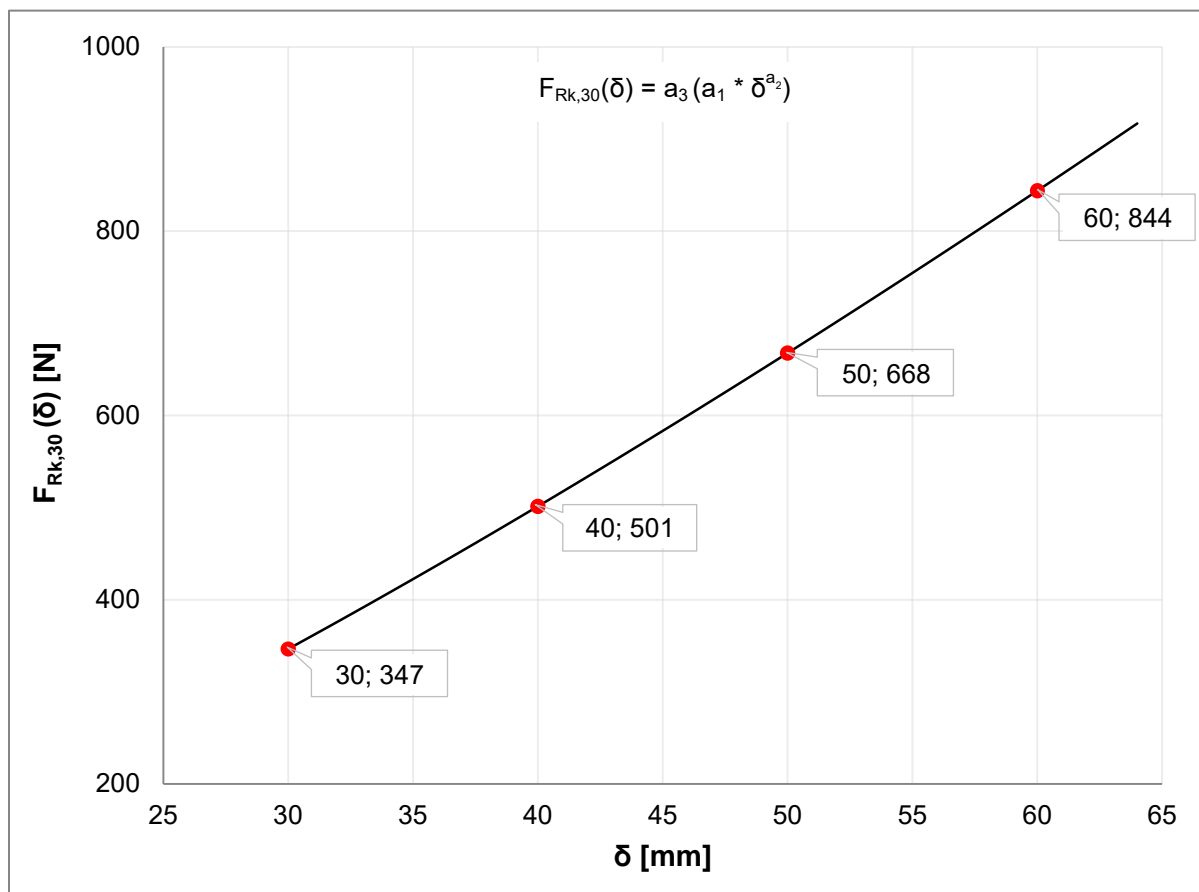

Figure D8: Regression curve according to Table D8

Symbols and designation see Annex D2

Hilti heavy-duty pipe rings MP-MI M10/M12 and Hilti heavy-duty pipe rings MP-MI M16

Load displacement function and deformations at elevated temperatures of heavy-duty pipe rings MP-MI 101.6 G - MP-MI 6" G

Annex D8

English translation prepared by DIBt

Table D9: Resistance $F_{Rk,t}$ of heavy-duty pipe rings MP-MI 4" C - MP-MI 6" C at elevated temperatures after $t = 30, 60, 90$ and 120 minutes

Item number	Designation	Parameter of regression curve $F_{Rk}(t) = c_3 (c_1 + c_2/t)$	$F_{Rk,t}$ [N]			
			$F_{Rk,30}$	$F_{Rk,60}$	$F_{Rk,90}$	$F_{Rk,120}$
20872	MP-MI 4" C	$c_1 = 503.452$ $c_2 = 29045.631$ $c_3 = 0.65549$ $23 \text{ min} \leq t \leq 131 \text{ min}$	965	647	542	489
20880	MP-MI 133 C					
229087	MP-MI 159 C					
20888	MP-MI 6" C					

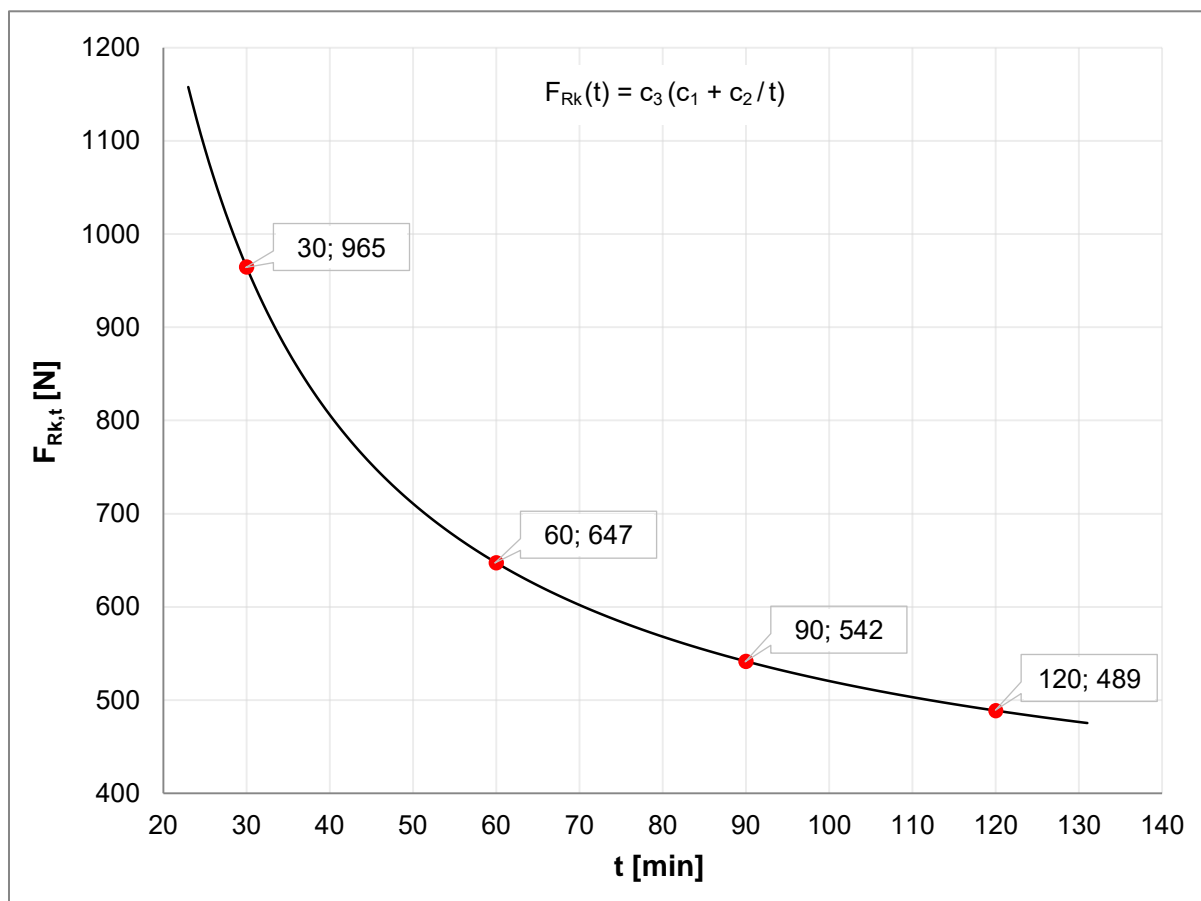

Figure D9: Regression curve according to Table D9

Hilti heavy-duty pipe rings MP-MI M10/M12 and Hilti heavy-duty pipe rings MP-MI M16

Resistance at elevated temperatures of heavy-duty pipe rings
MP-MI 4" C - MP-MI 6" C

Annex D9

electronic copy of the eta by dibt: eta-18/0130

Table D10: Load displacement function and deformations of heavy-duty pipe rings MP-MI 4" C - MP-MI 6" C under elevated temperatures

Item number	Designation	Parameter of regression curve $F_{Rk,30}(\delta) = a_3 (a_1 * \delta^{a_2})$	$F_{Rk,30}(\delta)$ [N]				$\delta_{max,t}$ [mm]		
			$F_{Rk,30}(30)$	$F_{Rk,30}(40)$	$F_{Rk,30}(50)$	$F_{Rk,30}(60)$	$\delta_{max,60}$	$\delta_{max,90}$	$\delta_{max,120}$
20872	MP-MI 4" C	$a_1 = 142.265$ $a_2 = 0.4671$ $a_3 = 0.5502$ $22 \text{ mm} \leq \delta \leq 62 \text{ mm}$	383	438	487	530	84	92	92
20880	MP-MI 133 C								
229087	MP-MI 159 C								
20888	MP-MI 6" C								

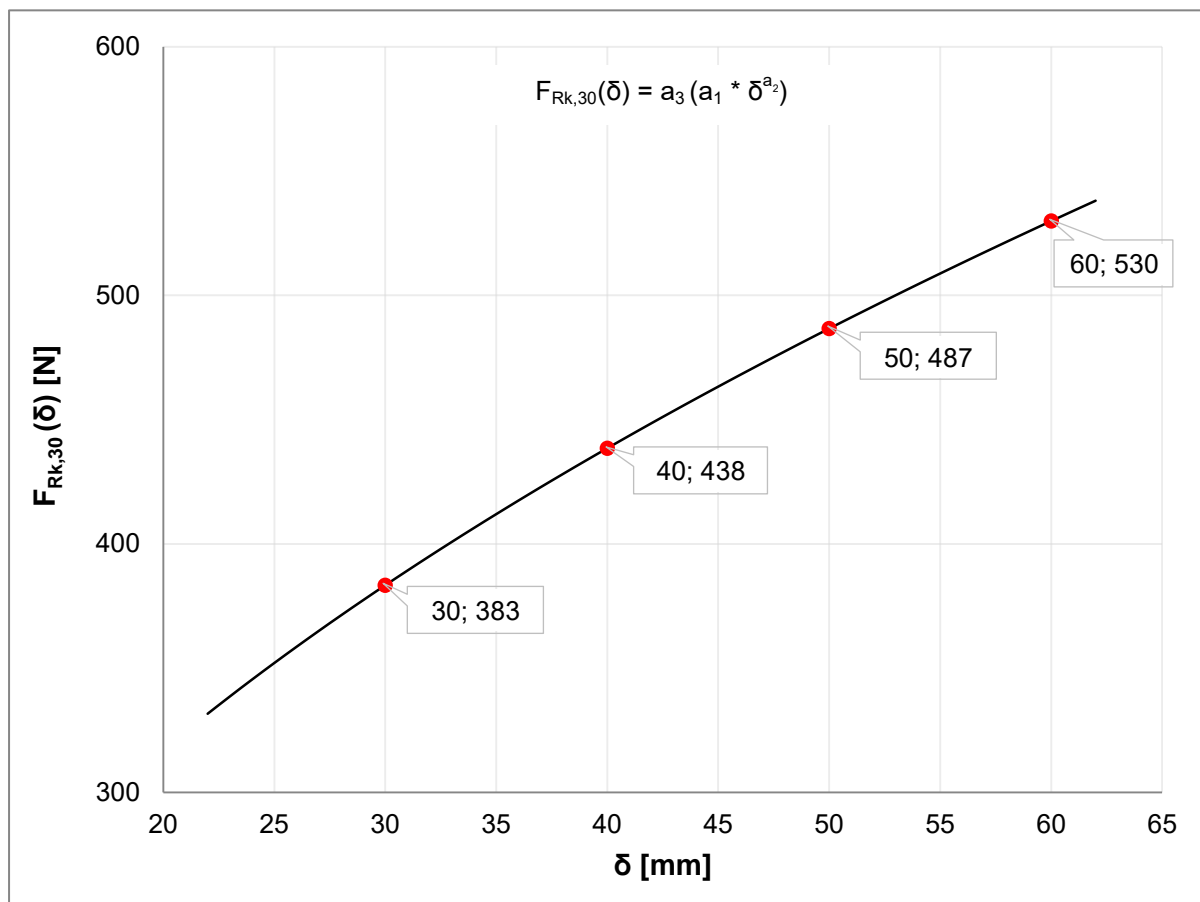

Figure D10: Regression curve according to Table D10

Symbols and designation see Annex D2

Hilti heavy-duty pipe rings MP-MI M10/M12 and Hilti heavy-duty pipe rings MP-MI M16

Load displacement function and deformations at elevated temperatures of heavy-duty pipe rings MP-MI 4" C - MP-MI 6" C

Annex D10

English translation prepared by DIBt

Table D11: Resistance $F_{Rk,t}$ of heavy-duty pipe rings MP-MI 177.8 C - MP-MI 244.5 C at elevated temperatures after $t = 30, 60, 90$ and 120 minutes

Item number	Designation	Parameter of regression curve $F_{Rk}(t) = c_3 (c_1 + c_2/t)$	$F_{Rk,t}$ [N]			
			$F_{Rk,30}$	$F_{Rk,60}$	$F_{Rk,90}$	$F_{Rk,120}$
20890	MP-MI 177.8 C	$c_1 = 457.914$ $c_2 = 58689.667$ $c_3 = 0.7436$ $26 \text{ min} \leq t \leq 150 \text{ min}$	1795	1068	825	704
20892	MP-MI 193.7 C					
20894	MP-MI 212 C					
20896	MP-MI 219.1 C					
20898	MP-MI 244.5 C					

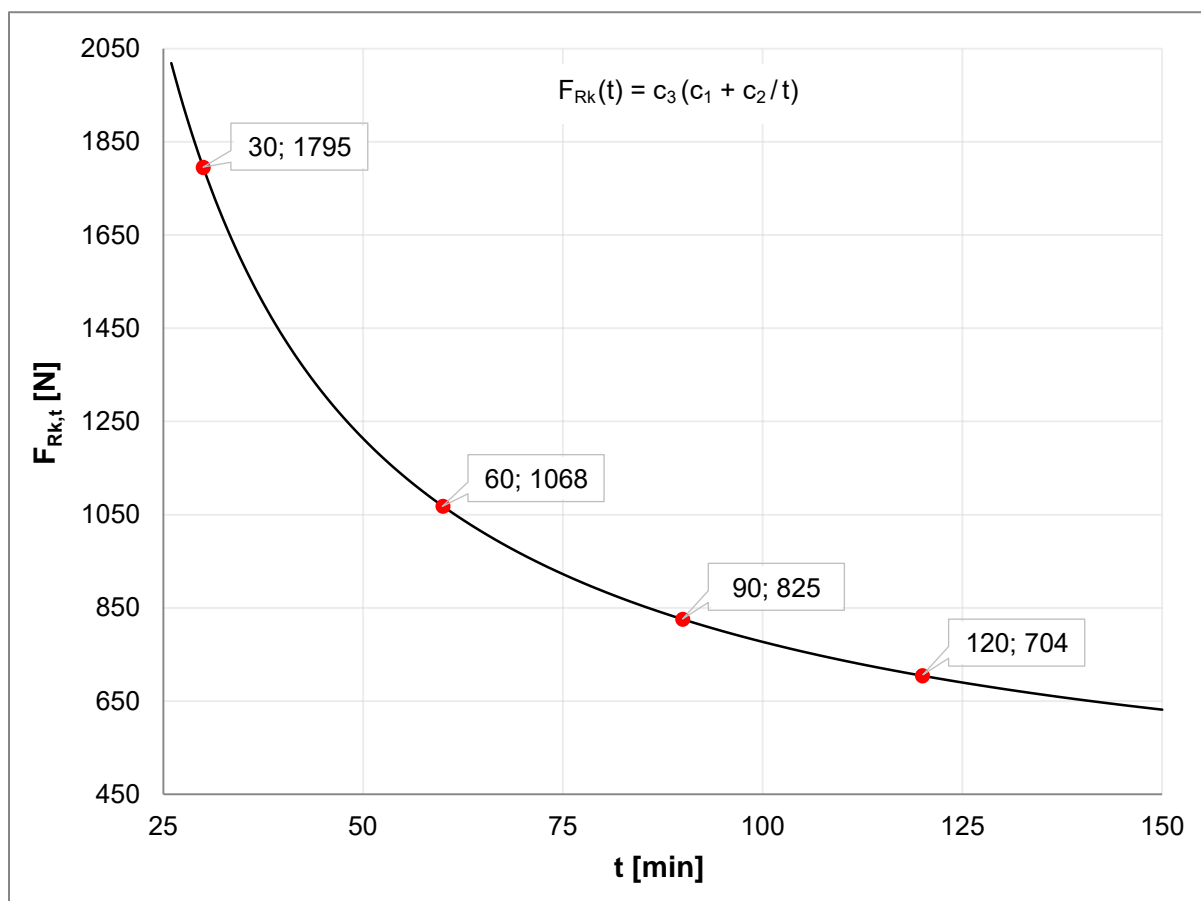

Figure D11: Regression curve according to Table D11

Hilti heavy-duty pipe rings MP-MI M10/M12 and Hilti heavy-duty pipe rings MP-MI M16

Resistance at elevated temperatures of heavy-duty pipe rings
MP-MI 177.8 C - MP-MI 244.5 C

Annex D11

Table D12: Load displacement function and deformations of heavy-duty pipe rings MP-MI 177.8 C - MP-MI 244.5 C under elevated temperatures

Item number	Designation	Parameter of regression curve $F_{Rk,30}(\delta) = a_3 (a_1 * \delta^{a_2})$	$F_{Rk,30}(\delta)$ [N]				$\delta_{max,t}$ [mm]		
			$F_{Rk,30}(20)$	$F_{Rk,30}(30)$	$F_{Rk,30}(40)$	$F_{Rk,30}(50)$	$\delta_{max,60}$	$\delta_{max,90}$	$\delta_{max,120}$
20890	MP-MI 177.8 C	$a_1 = 18.197$ $a_2 = 1.0675$ $a_3 = 0.70999$ $16 \text{ mm} \leq \delta \leq 67 \text{ mm}$	316	488	663	841	118	118	118
20892	MP-MI 193.7 C								
20894	MP-MI 212 C								
20896	MP-MI 219.1 C								
20898	MP-MI 244.5 C								

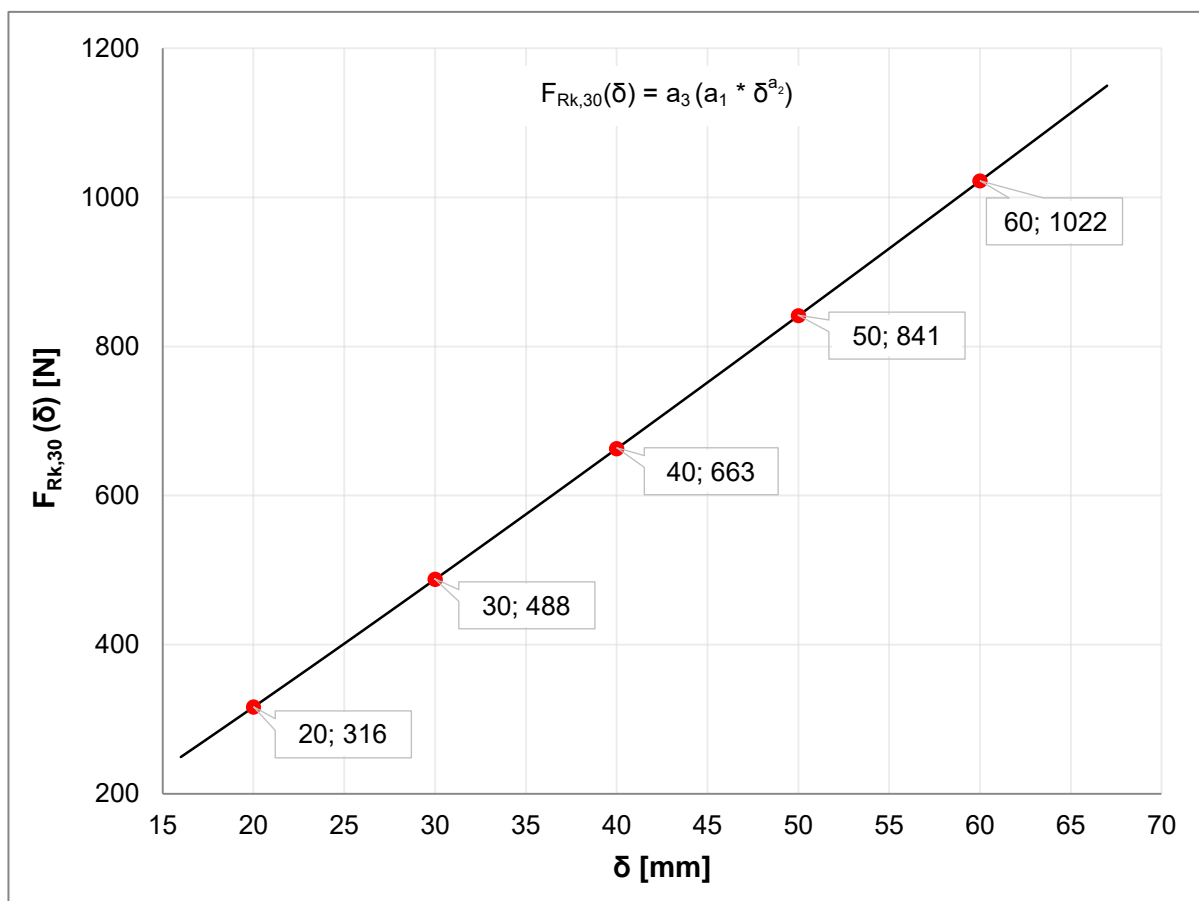

Figure D12: Regression curve according to Table D12

Symbols and designation see Annex D2

Hilti heavy-duty pipe rings MP-MI M10/M12 and Hilti heavy-duty pipe rings MP-MI M16

Load displacement function and deformations at elevated temperatures of heavy-duty pipe rings MP-MI 177.8 C - MP-MI 244.5 C

Annex D12

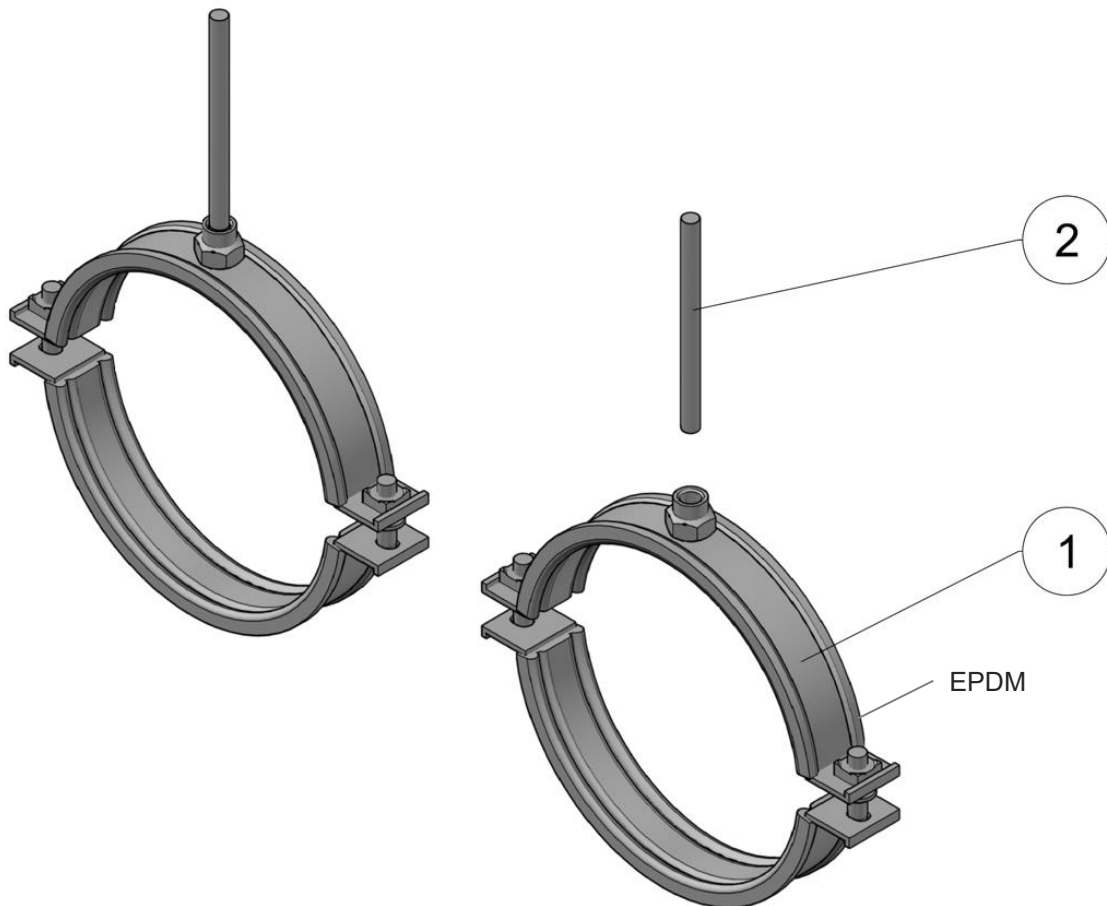

Legend

- 1 Heavy-duty pipe rings MP-MI
- 2 Threaded rods M10, M12 or M16 (not an integral part of this ETA)

Hilti heavy-duty pipe rings MP-MI M10/M12 and Hilti heavy-duty pipe rings MP-MI M16

Installation of heavy-duty pipe rings MP-MI with threaded rod
Exemplary representation of closing mechanism: M8 + nut

Annex E1
(informative)

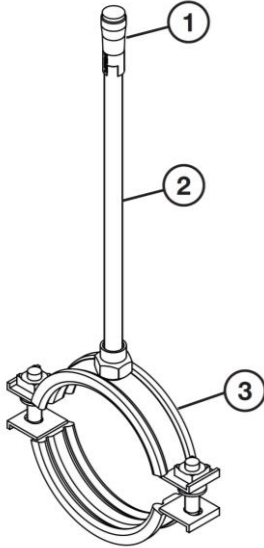

Bill of material / Stückliste					
Part of typical/ Applikationselement	Ref.	Opt.	Item no. / Artikel Nr.	Description / Bezeichnung	
Structure / Aufbau	Fixation / Befestigung	1	A	376967	HKD M10x40 drop-in anchor
		1	B	378544	HKD M12x50 drop-in anchor
		1	C	382941	HKD M16x65 drop-in anchor
		2	A	339795	AM10x1000 4.8 threaded rod*
		2	B	339797	AM12x1000 4.8 threaded rod*
		2	C	216422	AM16x1000 4.8 threaded rod*
Pipe Ring / Rohrschelle	M10/ M12/ M16	3	20843 - 20898	MP-MI (from 3/8" to 244.5C", with M10, 12, 16)	

* Threaded rod available in 1,2 & 3 meters / Gewindestange erhältlich in 1,2 & 3 Meter

Assembly Instructions / Montagehinweise

3

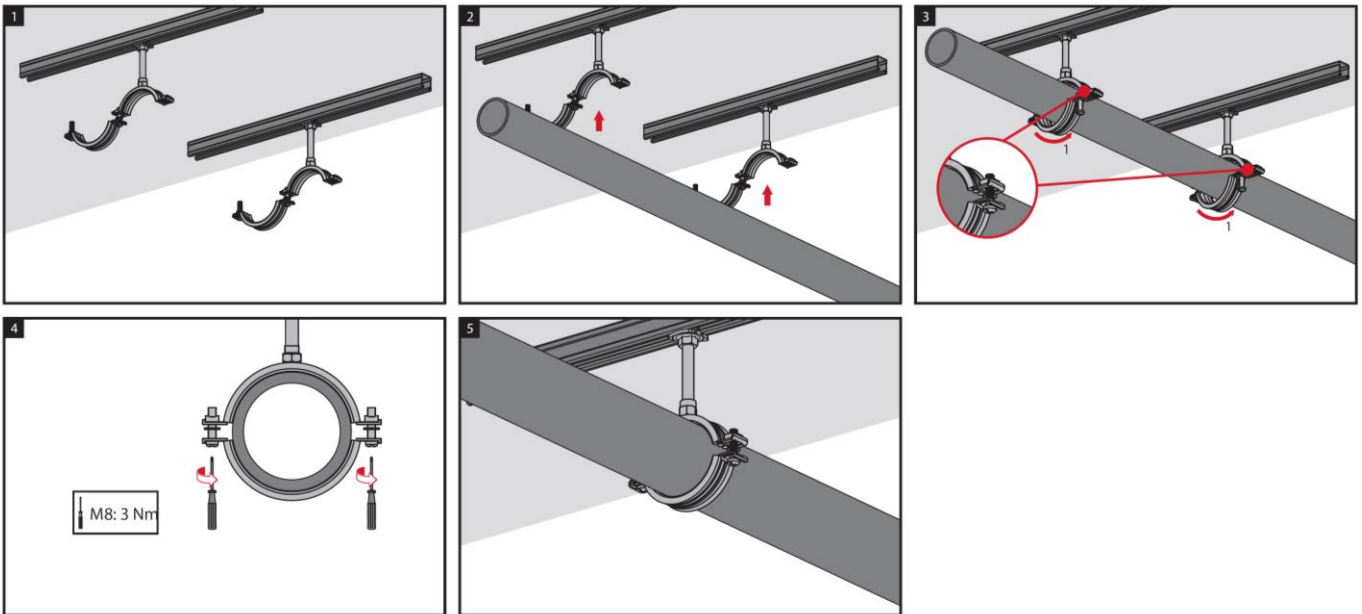

Hilti heavy-duty pipe rings MP-MI M10/M12 and Hilti heavy-duty pipe rings MP-MI M16

General assembly instructions

Annex E2
(informative)

Approval body for construction products
and types of construction

Bautechnisches Prüfamt

An institution established by the Federal and
Laender Governments



European Technical Assessment

ETA-18/0131
of 9 July 2018

English translation prepared by DIBt - Original version in German language

General Part

Technical Assessment Body issuing the
European Technical Assessment:

Deutsches Institut für Bautechnik

Trade name of the construction product

Hilti threaded rods AM10 x L 4.8, AM12 x L 4.8 and
AM16 x L 4.8

Product family
to which the construction product belongs

Products related to installation systems supporting
technical equipment for building services such as pipes,
conduits, ducts and cables

Manufacturer

Hilti AG
Feldkircherstraße 100
9494 Schaan
FÜRSTENTUM LIECHTENSTEIN

Manufacturing plant

L 1000405

This European Technical Assessment
contains

11 pages including 7 annexes which form an integral part
of this assessment

This European Technical Assessment is
issued in accordance with Regulation (EU)
No 305/2011, on the basis of

EAD 280016-00-0602

The European Technical Assessment is issued by the Technical Assessment Body in its official language. Translations of this European Technical Assessment in other languages shall fully correspond to the original issued document and shall be identified as such.

Communication of this European Technical Assessment, including transmission by electronic means, shall be in full. However, partial reproduction may only be made with the written consent of the issuing Technical Assessment Body. Any partial reproduction shall be identified as such.

This European Technical Assessment may be withdrawn by the issuing Technical Assessment Body, in particular pursuant to information by the Commission in accordance with Article 25(3) of Regulation (EU) No 305/2011.

Specific Part

1 Technical description of the product

Objects of this European Technical Assessment are the Hilti threaded rods AM10 x L 4.8, AM12 x L 4.8 and AM16 x L 4.8. The threaded rods are made of steel with the metric threads M10, M12 and M16. They are delivered in lengths of 1 m, 2 m and 3 m and are cut to length as required.

Annex A describes the dimensions and materials of the Hilti threaded rods AM10 x L 4.8, AM12 x L 4.8 and AM16 x L 4.8.

2 Specification of the intended use in accordance with the applicable European Assessment Document (EAD)

The performance given in Section 3 can only be assumed if the Hilti threaded rods AM10 x L 4.8, AM12 x L 4.8 and AM16 x L 4.8 are used in compliance with the specifications and under boundary conditions set out in Annex B. The test and assessment methods on which this European Technical Assessment is based lead to an assumption of a working life of the Hilti threaded rods AM10 x L 4.8, AM12 x L 4.8 and AM16 x L 4.8 of at least 50 years in final use under ambient temperatures in indoor areas. The indications given on the working life cannot be interpreted as a guarantee given by the producer, but are to be regarded only as a means for choosing the right products in relation to the expected economically reasonable working life of the works.

In accordance with the European Assessment Document EAD 280016-00-0602, the product is intended to be used in

- a) installations for the support of sprinkler kits;
- b) installations for the support of other building service elements such as pipes, conduits, ducts and cables.

3 Performance of the product and references to the methods used for its assessment

3.1 Safety in case of fire (BWR 2)

Essential characteristic	Performance
Reaction to fire	Class A1

3.2 Safety and accessibility in use (BWR 4)

Essential characteristic	Performance
Dimensions	see Annex A
Material	see Annex A
Resistance to combined bending and tension at elevated temperatures	see Annex C
Tension resistance at elevated temperatures	see Annex C
Compression resistance at elevated temperatures	see Annex C

4 Assessment and verification of constancy of performance (AVCP) system applied, with reference to its legal base

In accordance with the European Assessment Document EAD 280016-00-0602, the following legal bases apply:

- In case of intended use a) specified in Section 2:
Decision of the commission N° 1996/577/EC:
System 1 applies for the assessment and verification of constancy of performance (AVCP).
- In case of intended use b) specified in Section 2:
Decision of the commission N° 1999/472/EC:
System 3 applies for the assessment and verification of constancy of performance (AVCP).

5 Technical details necessary for the implementation of the AVCP system, as provided for in the applicable EAD

The technical details necessary for the implementation of the system for the assessment and verification of constancy of performance are laid down in the control plan (confidential part of this European Technical Assessment) deposited at Deutsches Institut für Bautechnik.

Issued in Berlin on 9 July 2018 by Deutsches Institut für Bautechnik

BD Dipl.-Ing. Andreas Kummerow
Head of Department

beglaubigt:
Häßler

Table A1: Dimensions and materials of threaded rods

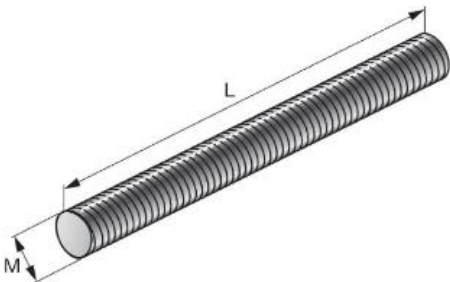
Illustration	Item number	Designation	M thread	L [mm]	Material
	339795	AM10x1000 4.8	M10	1000	Strength class 4.8 in accordance with DIN 976-1, zinc coated
	339796	AM10x2000 4.8	M10	2000	
	216418	AM10x3000 4.8	M10	3000	
	339797	AM12x1000 4.8	M12	1000	
	216420	AM12x2000 4.8	M12	2000	
	216421	AM12x3000 4.8	M12	3000	
	216422	AM16x1000 4.8	M16	1000	
	216423	AM16x2000 4.8	M16	2000	
	216424	AM16x3000 4.8	M16	3000	

Hilti threaded rods AM10 x L 4.8, AM12 x L 4.8 and AM16 x L 4.8

Product description
Dimensions and materials

Annex A

- Hilti threaded rods AM10 x L 4.8, AM12 x L 4.8 und AM16 x L 4.8 are used to transfer building services component loads such as ducts and equipment for sprinklers, water, heating, cooling, ventilation, electrical and other systems. Hilti threaded rods AM10 x L 4.8, AM12 x L 4.8 und AM16 x L 4.8 are performing this loadbearing function at elevated temperatures under the conditions described in Section 2 of this European Technical Assessment.
- Hilti threaded rods AM10 x L 4.8, AM12 x L 4.8 und AM16 x L 4.8 are deployed as thread connectors in installation systems. Typical examples for the application of threaded rods in installation systems are:
 - for suspending or mounting pipe clamps in conjunction with installation channels;
 - for suspending installation channels.
- If such systems are exposed to elevated temperatures, threaded rods are exposed to combined bending and tension stress as a result of a link polygon forming between the suspension points and the channel. The combined bending and tension resistance at elevated temperatures results with a cantilever arm length of threaded rod ≤ 150 mm. Installed horizontally in a furnace, the threaded rod is rigidly connected to a vertical channel and loaded at its outer end (see Figure B1).
- The resistance at elevated temperatures applies for static and centric actions.
- The time values in conjunction with the resistance values at elevated temperatures refer to the boundary conditions of the standard temperature / time curve (STTC) according to EN 1363-1.
- The anchoring used with the base material must be suitable and have a fireproof certificate.
- Prior to installation, it must be ensured that the supported component, the anchoring of the threaded rod to the base material and the base material itself are suitable to withstand the resistance values of the installation system and that they have a fireproof certificate.
- The threaded rods must be installed by appropriately qualified personnel and under the supervision of the site manager.

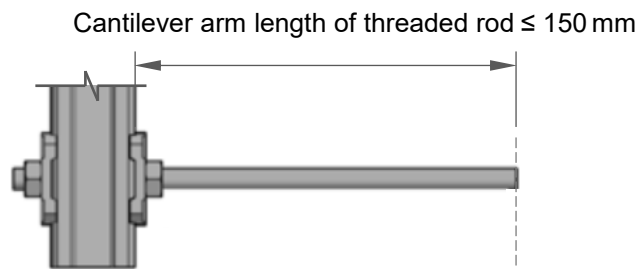

Figure B1: Installed threaded rod in conjunction with vertical channel

electronic copy of the eta by dibt: eta-18/0131

Hilti threaded rods AM10 x L 4.8, AM12 x L 4.8 and AM16 x L 4.8	Annex B
Requirements for performance assessment	

Table C1.1: Resistance to combined bending and tension load at elevated temperatures:
Parameter of regression curve $F_{Rk}(t) = c_3 (c_1 + c_2 / t)$ [N]

Designation	c_1 [-]	c_2 [-]	c_3 [-]	t_{min} [minutes]	t_{max} [minutes]
M10 threaded rods ¹⁾	260.907	29615.482	0.927769	30	146
M12 threaded rods	NPA ²⁾	NPA	NPA	NPA	NPA
M16 threaded rods	NPA	NPA	NPA	NPA	NPA

Table C1.2: Resistance $F_{Rk,t}$ to combined bending and tension load at elevated temperatures
after $t = 30, 60, 90$ and 120 minutes

Designation	$F_{Rk,30}$ [N]	$F_{Rk,60}$ [N]	$F_{Rk,90}$ [N]	$F_{Rk,120}$ [N]
M10 threaded rods ¹⁾	1158	700	547	471
M12 threaded rods	NPA ²⁾	NPA	NPA	NPA
M16 threaded rods	NPA	NPA	NPA	NPA

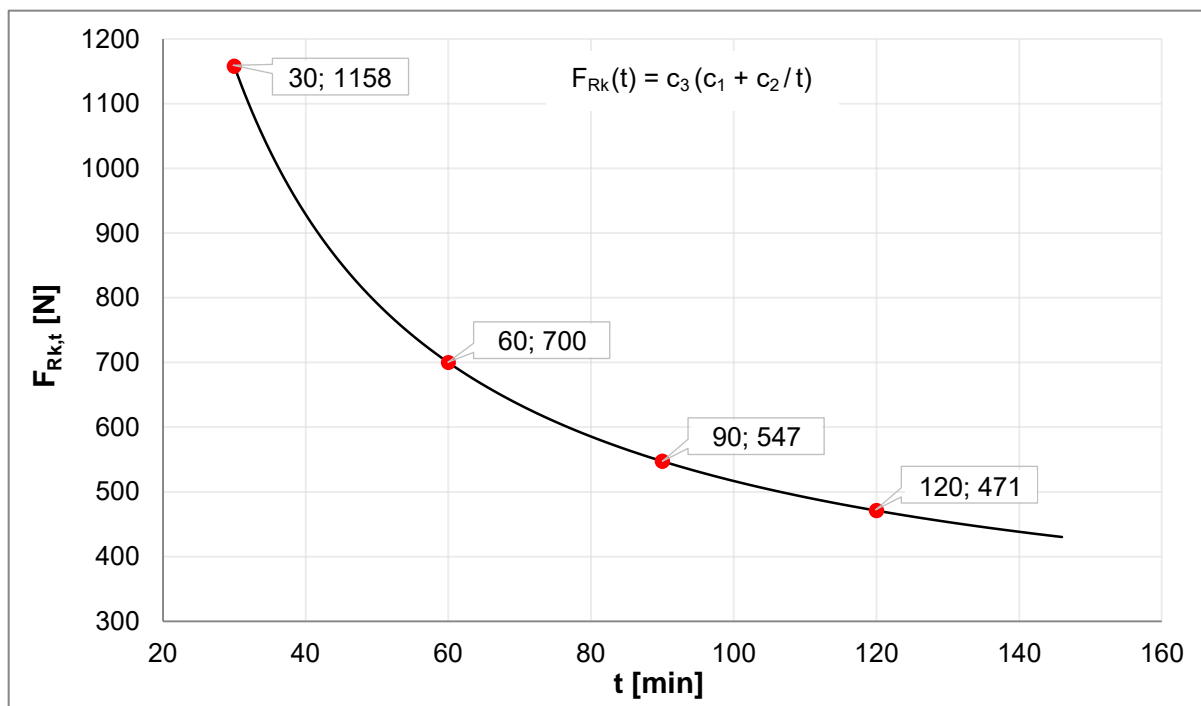

Figure C1: Resistance to combined bending and tension load for M10 threaded rods at elevated temperatures

- ¹⁾ Cantilever arm length of threaded rod ≤ 150 mm
- ²⁾ NPA: No performance assessed

Hilti threaded rods AM10 x L 4.8, AM12 x L 4.8 and AM16 x L 4.8

Resistance to combined bending and tension at elevated temperatures

Annex C1

Table C2.1: Calculation-based tension resistance $F_{Rk,t}$ at elevated temperatures after $t = 30, 60, 90$ and 120 minutes

Designation	$F_{Rk,30}$ [N]	$F_{Rk,60}$ [N]	$F_{Rk,90}$ [N]	$F_{Rk,120}$ [N]
M10 threaded rods	1650	950	720	560
M12 threaded rods	2400	1380	1050	810
M16 threaded rods	4470	2560	1950	1520

Table C2.2: Calculation-based compression resistance $F_{Rk,t}$ at elevated temperatures after $t = 30, 60, 90$ and 120 minutes for M10 threaded rods

Installed length L [mm]	$F_{Rk,30}$ [N]	$F_{Rk,60}$ [N]	$F_{Rk,90}$ [N]	$F_{Rk,120}$ [N]
40	1240	740	560	440
50	1140	680	520	400
60	1030	630	480	370
70	920	570	430	340
80	820	520	390	310
90	720	460	350	280
100	640	420	320	250
110	570	370	280	220
120	500	330	250	200
130	450	300	230	180
140	400	270	200	160
150	360	240	180	140
160	320	220	170	130
170	290	200	150	120
180	260	180	140	110
190	240	170	130	100
200	220	150	120	90
210	200	140	110	80
220	190	130	100	80
230	170	120	90	70
240	160	110	80	70
250	150	100	80	60
260	140	100	70	60
270	130	90	70	50
280	120	80	60	50
290	110	80	60	50
300	110	70	60	40
310	100	70	50	40

Hilti threaded rods AM10 x L 4.8, AM12 x L 4.8 and AM16 x L 4.8

Tension resistance at elevated temperatures
Compression resistance at elevated temperatures

Annex C2

Table C3: Calculation-based compression resistance $F_{Rk,t}$ at elevated temperatures after $t = 30, 60, 90$ and 120 minutes for M12 threaded rods

Installed length L [mm]	$F_{Rk,30}$ [N]	$F_{Rk,60}$ [N]	$F_{Rk,90}$ [N]	$F_{Rk,120}$ [N]
40	1910	1120	850	660
50	1780	1060	810	630
60	1650	990	760	590
70	1520	930	710	550
80	1390	860	650	510
90	1270	790	600	470
100	1150	730	550	430
110	1040	670	510	390
120	930	610	460	360
130	840	550	420	330
140	760	510	380	300
150	690	460	350	270
160	630	420	320	250
170	570	390	290	230
180	520	360	270	210
190	480	330	250	190
200	440	300	230	180
210	410	280	210	170
220	380	260	200	150
230	350	240	180	140
240	320	220	170	130
250	300	210	160	120
260	280	190	150	120
270	260	180	140	110
280	250	170	130	100
290	230	160	120	100
300	220	150	120	90
330	180	130	100	80
360	160	110	80	60
390	130	90	70	60
420	120	80	60	50
450	100	70	60	40

Hilti threaded rods AM12 x L 4.8

Compression resistance at elevated temperatures

Annex C3

Table C4: Calculation-based compression resistance $F_{Rk,t}$ at elevated temperatures after $t = 30$, 60, 90 and 120 minutes for M16 threaded rods

Installed length L [mm]	$F_{Rk,30}$ [N]	$F_{Rk,60}$ [N]	$F_{Rk,90}$ [N]	$F_{Rk,120}$ [N]
40	3800	2210	1680	1310
50	3630	2130	1620	1260
60	3460	2040	1560	1210
70	3290	1960	1490	1160
80	3120	1870	1420	1110
90	2940	1780	1350	1050
100	2760	1690	1280	1000
110	2580	1590	1210	940
120	2410	1500	1140	890
130	2240	1410	1080	840
140	2080	1330	1010	790
150	1930	1240	940	740
160	1790	1160	880	690
170	1660	1090	830	640
180	1540	1020	770	600
190	1430	950	720	560
200	1330	890	680	530
210	1240	830	630	490
220	1160	780	590	460
230	1080	730	560	430
240	1010	690	520	410
250	950	640	490	380
260	890	610	460	360
270	840	570	430	340
280	790	540	410	320
290	740	510	390	300
300	700	480	370	290
330	600	410	310	240
360	510	350	270	210
390	440	310	230	180
420	390	270	210	160
450	340	240	180	140

Hilti threaded rods AM16 x L 4.8

Compression resistance at elevated temperatures

Annex C4

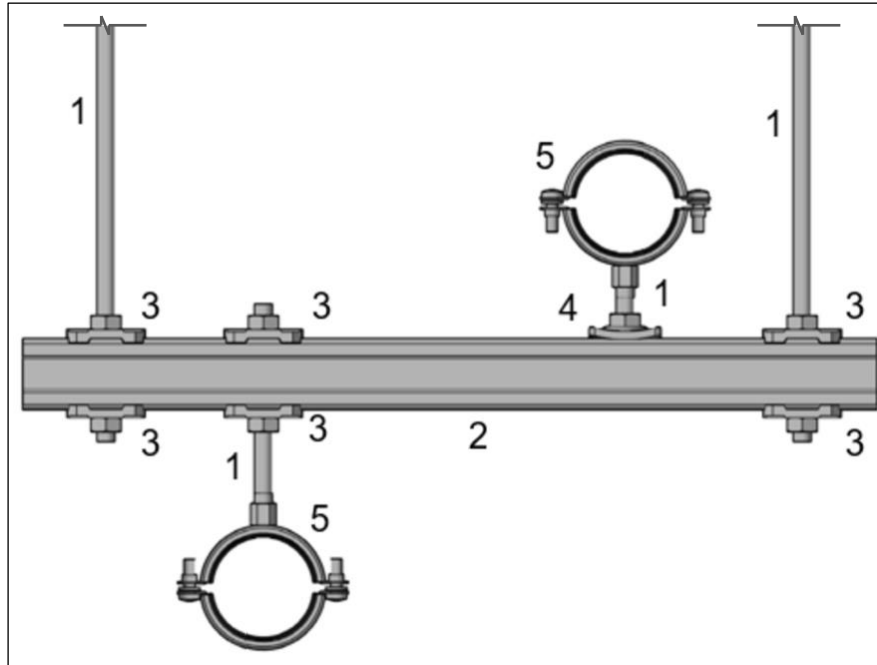

Legend

- 1 Threaded rod
The fastening of the threaded rods to the base material is made with appropriate anchors.
- 2 Installation channel (not an integral part of this ETA)
- 3 Drilled plates with hexagonal nuts (not an integral part of this ETA)
- 4 Pipe ring saddle (not an integral part of this ETA)
- 5 Pipe ring (not an integral part of this ETA)

Hilti threaded rods AM10 x L 4.8, AM12 x L 4.8 and AM16 x L 4.8

Threaded rods on suspended rails

Annex D
(informative)

Approval body for construction products
and types of construction

Bautechnisches Prüfamt

An institution established by the Federal and
Laender Governments



European Technical Assessment

ETA-18/0132
of 25 July 2018

English translation prepared by DIBt - Original version in German language

General Part

Technical Assessment Body issuing the
European Technical Assessment:

Deutsches Institut für Bautechnik

Trade name of the construction product

Hilti pipe ring saddle MQA-M10-B,
Hilti pipe ring saddle MQA-M12-B and
Hilti pipe ring saddle MQA-M16-B

Product family
to which the construction product belongs

Products related to installation systems supporting
technical equipment for building services such as pipes,
conduits, ducts and cables

Manufacturer

Hilti AG
Feldkircherstraße 100
9494 Schaan
FÜRSTENTUM LIECHTENSTEIN

Manufacturing plant

L 1000446

This European Technical Assessment
contains

16 pages including 12 annexes which form an integral
part of this assessment

This European Technical Assessment is
issued in accordance with Regulation (EU)
No 305/2011, on the basis of

EAD 280016-00-0602

The European Technical Assessment is issued by the Technical Assessment Body in its official language. Translations of this European Technical Assessment in other languages shall fully correspond to the original issued document and shall be identified as such.

Communication of this European Technical Assessment, including transmission by electronic means, shall be in full. However, partial reproduction may only be made with the written consent of the issuing Technical Assessment Body. Any partial reproduction shall be identified as such.

This European Technical Assessment may be withdrawn by the issuing Technical Assessment Body, in particular pursuant to information by the Commission in accordance with Article 25(3) of Regulation (EU) No 305/2011.

Specific Part

1 Technical description of the product

Objects of this European Technical Assessment are the Hilti pipe ring saddle MQA-M10-B, Hilti pipe ring saddle MQA-M12-B and Hilti pipe ring saddle MQA-M16-B. The MQA-M10-B, MQA-M12-B and MQA-M16-B pipe ring saddles consist of a nut and a clamping plate made of steel, which are connected to one another by means of a spring element made of PET. The pipe ring saddles have a centred round opening. The opening in the nut is used to fasten threaded elements, e.g. threaded rods.

Annex A describes the dimensions and materials of the MQA-M10-B, MQA-M12-B and MQA-M16-B pipe ring saddles.

2 Specification of the intended use in accordance with the applicable European Assessment Document (EAD)

The performance given in Section 3 can only be assumed if the Hilti MQA-M10-B, MQA-M12-B and MQA-M16-B pipe ring saddles are used in compliance with the specifications and under boundary conditions set out in Annex B. The test and assessment methods on which this European Technical Assessment is based lead to an assumption of a working life of the Hilti MQA-M10-B, MQA-M12-B and MQA-M16-B pipe ring saddles of at least 50 years in final use under ambient temperatures in indoor areas. The indications given on the working life cannot be interpreted as a guarantee given by the producer, but are to be regarded only as a means for choosing the right products in relation to the expected economically reasonable working life of the works.

In accordance with the European Assessment Document EAD 280016-00-0602, the product is intended to be used in

- a) installations for the support of sprinkler kits;
- b) installations for the support of other building service elements such as pipes, conduits, ducts and cables.

3 Performance of the product and references to the methods used for its assessment

3.1 Safety in case of fire (BWR 2)

Essential characteristic	Performance
Reaction to fire: Steel	Class A1
Reaction to fire: Plastic parts	not relevant for fire growth in accordance with TR021 and therefore do not need to be classified

3.2 Safety and accessibility in use (BWR 4)

Essential characteristic	Performance
Shape	see Annex A
Dimensions	see Annex A
Material	see Annex A
Characteristic pull-out resistance at ambient temperatures	see Annex C
Pull-out resistance with $\varepsilon_{B,\theta a} \leq 2\%$ at elevated temperatures	see Annex D
Pull-out resistance with $\varepsilon_{B,\theta a} > 2\%$ at elevated temperatures	see Annex D

4 Assessment and verification of constancy of performance (AVCP) system applied, with reference to its legal base

In accordance with the European Assessment Document EAD 280016-00-0602, the following legal bases apply:

- In case of intended use a) specified in Section 2:
Decision of the commission N° 1996/577/EC:
System 1 applies for the assessment and verification of constancy of performance (AVCP).
- In case of intended use b) specified in Section 2:
Decision of the commission N° 1999/472/EC:
System 3 applies for the assessment and verification of constancy of performance (AVCP).

5 Technical details necessary for the implementation of the AVCP system, as provided for in the applicable EAD

The technical details necessary for the implementation of the system for the assessment and verification of constancy of performance are laid down in the control plan (confidential part of this European Technical Assessment) deposited at Deutsches Institut für Bautechnik.

Issued in Berlin on 25 Juli 2018 by Deutsches Institut für Bautechnik

BD Dipl.-Ing. Andreas Kummerow
Head of Department

beglaubigt:
Dr. Häßler

Table A1.1: Dimensions and materials of the pipe ring saddles

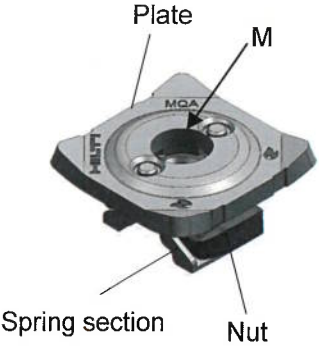
Illustration	Item number	Designation	M [mm]	Materials
	2199452	MQA-M10-B	10	Plate: DD11 in accordance with EN 10111 ¹⁾ , zinc coated
	2199453	MQA-M12-B	12	
	2199454	MQA-M16-B	16	Nut: C4C in accordance with EN 10263-2, zinc coated Spring section: PET

¹⁾ with $235 \text{ N/mm}^2 \leq R_{eL} \leq 340 \text{ N/mm}^2$, Method of deoxidation: fully killed

Table A1.2: Dimensions of the components of the pipe ring saddle MQA-M10-B [in mm]

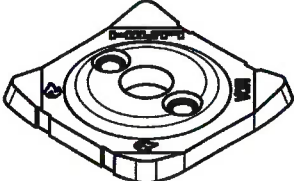
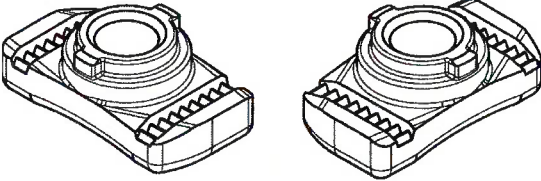
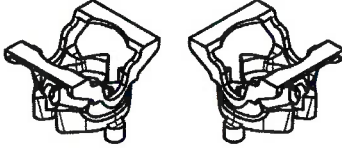
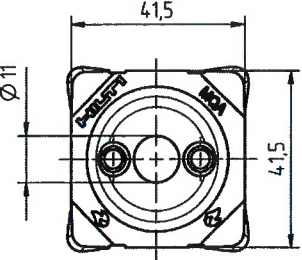
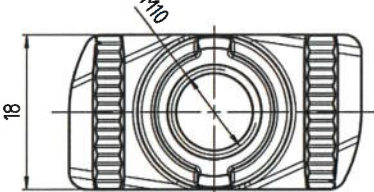
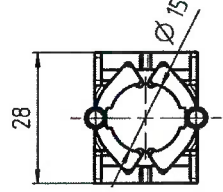
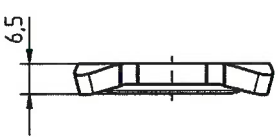
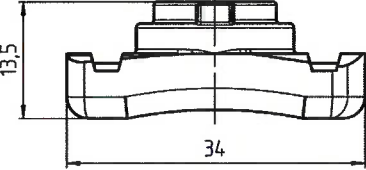
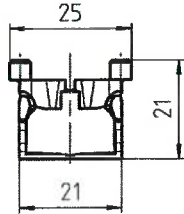
Plate	Nut	Spring section
		
		
		

Hilti pipe ring saddle MQA-M10-B, Hilti pipe ring saddle MQA-M12-B and Hilti pipe ring saddle MQA-M16-B

Description of the product
Dimensions and materials

Annex A1

Table A2.1: Dimensions of the components of the pipe ring saddle MQA-M12-B [in mm]

Plate	Nut	Spring section
		
		
		

Table A2.2: Dimensions of the components of the pipe ring saddle MQA-M16-B [in mm]

Plate	Nut	Spring section
		
		
		

Hilti pipe ring saddle MQA-M10-B, Hilti pipe ring saddle MQA-M12-B and
Hilti pipe ring saddle MQA-M16-B

Description of the product
Dimensions and materials

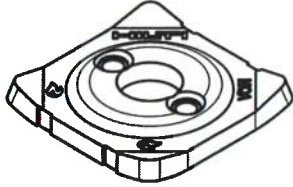
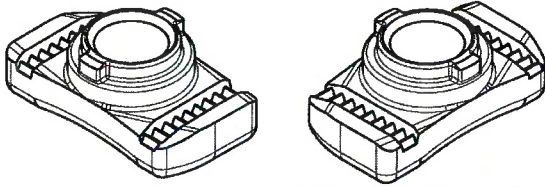
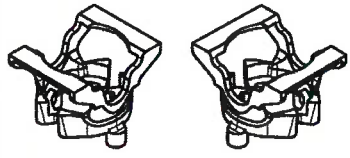
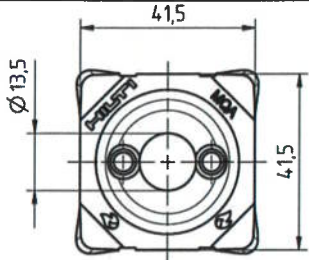
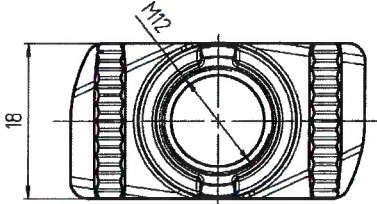
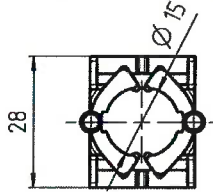
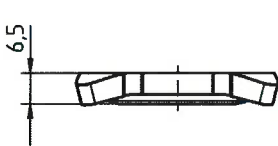
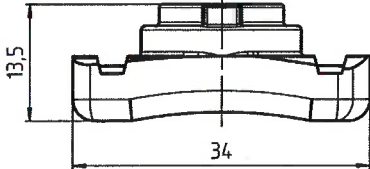
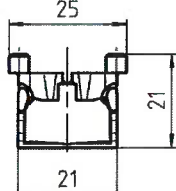
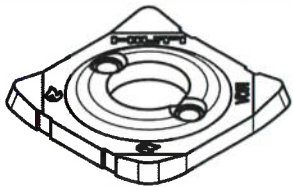
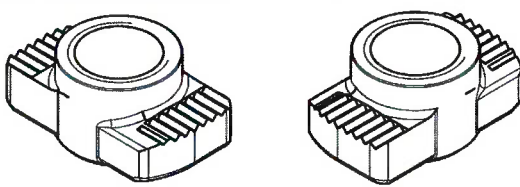
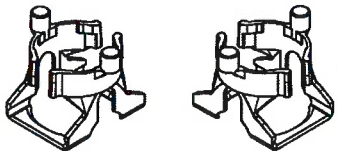
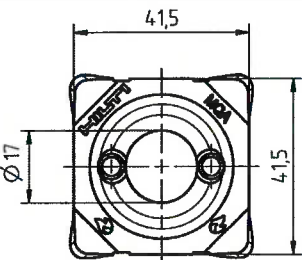
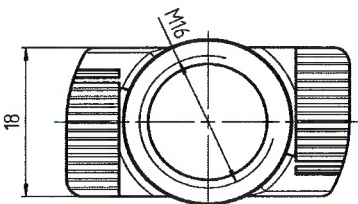
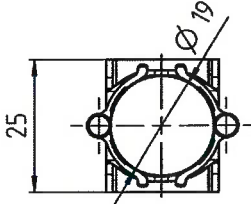
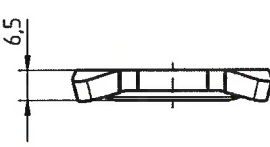
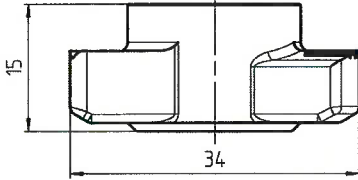
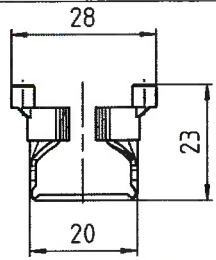
Annex A2

English translation prepared by DIBt

- Hilti pipe ring saddles MQA-M10-B, MQA-M12-B und MQA-M16-B are used to transfer building services component loads such as ducts and equipment for sprinklers, water, heating, cooling, ventilation, electrical and other systems. Hilti pipe ring saddles MQA-M10-B, MQA-M12-B und MQA-M16-B are performing this loadbearing function at ambient and elevated temperatures under the conditions described in Section 2 of this European Technical Assessment.
- Hilti pipe ring saddles MQA-M10-B, MQA-M12-B und MQA-M16-B are deployed for the fixation of threaded rods in installation systems in combination with hexagonal nuts.
- The performance of MQA-M10-B, MQA-M12-B and MQA-M16-B results in connection with zinc coated threaded rods of strength class 4.8 in accordance with DIN 976-1 as per Table B2.1, zinc coated hexagonal nuts of strength class 8 in accordance with ISO 4032 as per Table B2.2 and installation channels according to Annex B3 to B6.
- Information on resistance at ambient and elevated temperatures applies to static and centric actions. The time values in conjunction with the resistance values at elevated temperatures refer to the boundary conditions of the standard temperature / time curve (STTC) according to EN 1363-1.
- The channels are cut to length centrally between the longholes or the roundholes at the marking. The cut channel lies within a range of 2 mm from both sides of the marking.
- Prior to installation, it must be ensured that the supported components, the threaded rods, the anchoring to the base material and the base material itself are suitable to withstand the resistance values of the pipe ring saddles as well as of the installation system and that they have a fireproof certificate.
- Installation must be carried out by qualified personnel and under the supervision of the site manager. The general assembly instructions of the manufacturer apply.

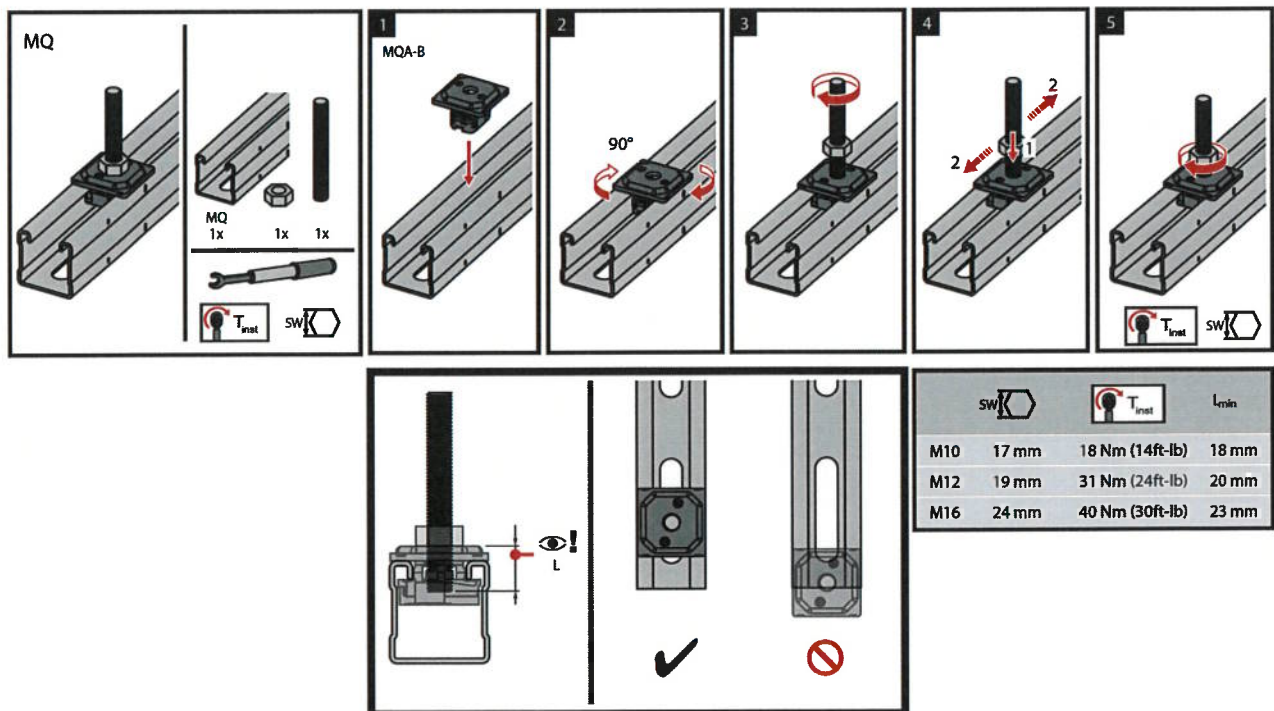

Hilti pipe ring saddle MQA-M10-B, Hilti pipe ring saddle MQA-M12-B and
Hilti pipe ring saddle MQA-M16-B

Requirements for performance assessment

Annex B1

Table B2.1: Dimensions and materials of threaded rods for use with MQA-M10-B, MQA-M12-B, MQA-M16-B

Illustration	Item number	Designation	M thread	L [mm]	Material
	339795	AM10x1000 4.8	M10	1000	Strength class 4.8 in accordance with DIN 976-1, zinc coated
	339796	AM10x2000 4.8	M10	2000	
	216418	AM10x3000 4.8	M10	3000	
	339797	AM12x1000 4.8	M12	1000	
	216420	AM12x2000 4.8	M12	2000	
	216421	AM12x3000 4.8	M12	3000	
	216422	AM16x1000 4.8	M16	1000	
	216423	AM16x2000 4.8	M16	2000	
	216424	AM16x3000 4.8	M16	3000	

Table B2.2: Dimensions and materials of hexagonal nuts for use with MQA-M10-B, MQA-M12-B, MQA-M16-B

Illustration	Item number	Designation	M thread	W [mm]	H [mm]	Material
	216466	M10 hexagonal nut	M10	17	8	Strength class 8 in accordance with ISO 4032, zinc coated
	216467	M12 hexagonal nut	M12	19	10	
	216468	M16 hexagonal nut	M16	24	13	

Hilti pipe ring saddle MQA-M10-B, Hilti pipe ring saddle MQA-M12-B and Hilti pipe ring saddle MQA-M16-B

Requirements for performance assessment

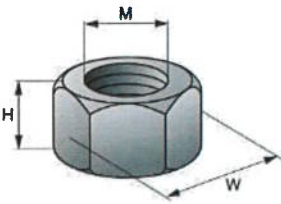
Annex B2

English translation prepared by DIBt

Table B3: Dimensions and materials of installation channels MQ-41/3, MQ-41/3 LL und MQ-41 D

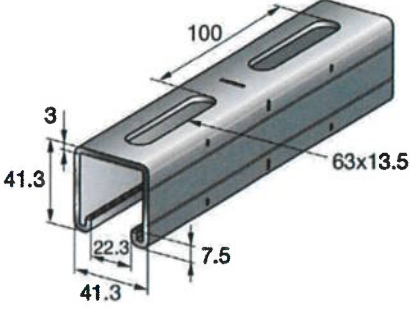
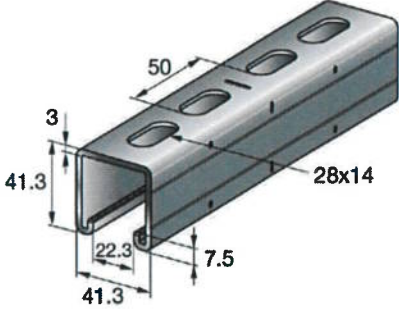
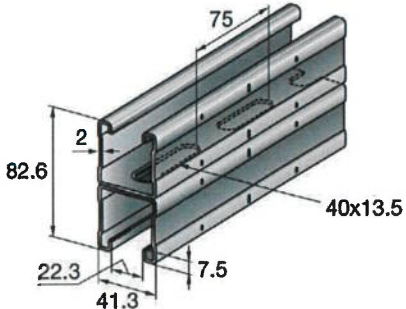
Illustration ²⁾	Item number	Designation	Length [m]	Materials
	369596	MQ-41/3 3M	3	S250GD+Z275-M-A-C in accordance with EN 10346
	369597	MQ-41/3 6M	6	
	2048102	MQ-41/3 3M LL	3	S250GD+Z275-M-A-C in accordance with EN 10346
	2048103	MQ-41/3 6M LL	6	
 <p>Two profiles of MQ-41 D channel are connected in the area of the holes in the back of the channels in a shape-fitting and force-fitting way as a kind of riveted connection.</p>	369603	MQ-41 D 3m	3	S250GD+Z275-M-A-C in accordance with EN 10346
	369604	MQ-41 D 6m	6	

²⁾ Dimensions in mm

Hilti pipe ring saddle MQA-M10-B, Hilti pipe ring saddle MQA-M12-B and
Hilti pipe ring saddle MQA-M16-B

Requirements for performance assessment

Annex B3

Table B4: Dimensions and materials of installation channels MQ-21.5, MQ-41 und MQ-41-L

Illustration ²⁾	Item number	Designation	Length [m]	Materials
	2184773	MQ-21.5 6m	6	S280GD+Z140-M-A-C in accordance with EN 10346
	2184772	MQ-21.5 3m	3	
	2184771	MQ-21.5 2m	2	
	369592	MQ-41 6m	6	S250GD+Z275-M-A-C in accordance with EN 10346
	369591	MQ-41 3m	3	
	304559	MQ-41 2m	2	
	2141964	MQ-41-L 6m	6	S250GD+Z140-M-A-C in accordance with EN 10346
	2141965	MQ-41-L 3m	3	
	2141966	MQ-41-L 2m	2	

²⁾ Dimensions in mm

Hilti pipe ring saddle MQA-M10-B, Hilti pipe ring saddle MQA-M12-B and
Hilti pipe ring saddle MQA-M16-B

Requirements for performance assessment

Annex B4

Table B5: Section properties of installation channels for use with MQA-M10-B, MQA-M12-B, MQA-M16-B

Description	Symbol	MQ-41/3	MQ-41/3 LL	MQ-41 D	MQ-21.5	MQ-41	MQ-41-L	Unit
Classification cross section in accordance with EN 1993-1-1	-	3	3	3	3	3	3	-
Cross section areas	A	375.88	379.93	545.97	142.71	263.62	199.57	mm ²
	A _{tot}	375.88	379.93	545.97	142.71	263.62	199.57	mm ²
Shear areas	A _y	48.69	54.43	66.37	23.47	27.23	20.24	mm ²
	A _z	195.47	194.59	197.58	41.86	131.51	98.37	mm ²
Centroid position	y _{C,0}	19.15	19.15	0.00	0.00	19.65	0.00	mm
	z _{C,0}	20.57	20.76	0.00	-9.12	20.52	-19.91	mm
Moments of inertia	I _y	76963.50	78224.80	323585.00	9168.75	57501.00	44773.00	mm ⁴
	I _z	107949.00	108011.00	154070.00	37416.40	76416.00	58981.50	mm ⁴
Inclination of principal axes	α	90.00	90.00	0.00	90.00	90.00	90.00	°
Polar moments of inertia	I _p	184913.00	186236.00	477656.00	46585.10	133917.00	103754.00	mm ⁴
	I _{p,M}	778900.00	780561.00	477656.00	115093.00	601859.00	469974.00	mm ⁴
Radii of gyration	i _y	14.31	14.35	24.35	8.02	14.77	14.98	mm
	i _z	16.95	16.86	16.80	16.19	17.03	17.19	mm
Polar radii of gyration	i _p	22.18	22.14	29.58	18.07	22.54	22.80	mm
	i _{p,M}	45.52	45.33	29.58	28.40	47.78	48.53	mm
Warping radius of gyration	i _{ω,M}	7.02	7.02	17.32	6.85	7.19	7.44	mm
Torsional constant	J	848.88	856.29	575.03	76.58	269.75	112.13	mm ⁴
Secondary torsional constant	J _s	105319.00	105394.00	91246.30	25157.50	74075.40	565590.00	mm ⁴
Location of the shear center	y _{M,0}	19.15	19.15	0.00	0.00	19.65	0.00	mm
	z _{M,0}	60.32	60.31	0.00	12.77	62.63	22.92	mm
	y _M	0.00	0.00	0.00	0.00	0.00	0.00	mm
	z _M	39.75	39.55	0.00	21.90	42.11	42.84	mm
Warping constants	I _{ω,C}	2.09277E+08	2.07678E+08	1.43225E+08	23255400.00	1.66135E+08	1.34296E+08	mm ⁶
	I _{ω,M}	38387600	38417600.00	1.43225E+08	5395050.00	31116700.00	26017600	mm ⁶
	r _{ω,M}	0.00	0.00	0.00	0.00	0.00	0.00	-
Section moduli	S _{y,max}	4002.48	4108.45	7834.29	928.54	2906.72	2248.07	mm ³
	S _{y,min}	-3487.10	-3514.15	-7833.74	-788.66	-2672.22	-2093.62	mm ³
	S _{z,max}	5227.58	5230.56	7460.71	1811.93	3700.53	2856.29	mm ³
	S _{z,min}	-5277.58	-5230.56	-7460.71	-1811.93	-3700.54	-2856.25	mm ³
Torsional section modulus	S _t	282.96	285.43	287.51	51.06	134.88	75.76	mm ³
Max. plastic bending moment	M _{pl,y,k}	NPA ³⁾	NPA	NPA	NPA	NPA	NPA	kNm
	M _{pl,z,k}	NPA	NPA	NPA	NPA	NPA	NPA	kNm
Max. plastic section moduli	Z _y	NPA	NPA	NPA	NPA	NPA	NPA	mm ³
	Z _z	NPA	NPA	NPA	NPA	NPA	NPA	mm ³
Plastic shear areas	A _{pl,y}	NPA	NPA	NPA	NPA	NPA	NPA	mm ²
	A _{pl,z}	NPA	NPA	NPA	NPA	NPA	NPA	mm ²
Area bisecting axis position	f _{y,0}	NPA	NPA	NPA	NPA	NPA	NPA	mm
	f _{z,0}	NPA	NPA	NPA	NPA	NPA	NPA	mm
Plastic shear forces	V _{pl,y,k}	NPA	NPA	NPA	NPA	NPA	NPA	kN
	V _{pl,z,k}	NPA	NPA	NPA	NPA	NPA	NPA	kN
Plastic axial force	N _{pl,k}	NPA	NPA	NPA	NPA	NPA	NPA	kN
Buckling curves	BC _y	c	c	c	c	c	c	-
	BC _z	c	c	c	c	c	c	-

³⁾ NPA: No performance assessed

Hilti pipe ring saddle MQA-M10-B, Hilti pipe ring saddle MQA-M12-B and Hilti pipe ring saddle MQA-M16-B

Requirements for performance assessment

Annex B5

English translation prepared by DIBt

Table B6.1: Channel material stress⁴⁾ at different temperatures of the component and $\varepsilon_{B,0a} = 2\%$

Temperature [°C]	Stress [N/mm ²]			
	MQ-41/3 or MQ-41/3 LL	MQ-41	MQ-41-L	MQ-21.5
800	26.51	25.06	20.83	28.53
842*	19.00	16.77	14.11	21.80
850	17.57	15.19	12.83	20.52
900	12.82	11.21	10.69	17.24
945*	12.05	10.49	9.19	12.91
950	11.96	10.41	9.02	12.43
1000	10.58	8.82	7.02	10.52
1006*	10.50	8.72	6.98	10.48
1049*	9.91	7.97	6.73	10.18
1050	9.90	7.96	6.73	10.17

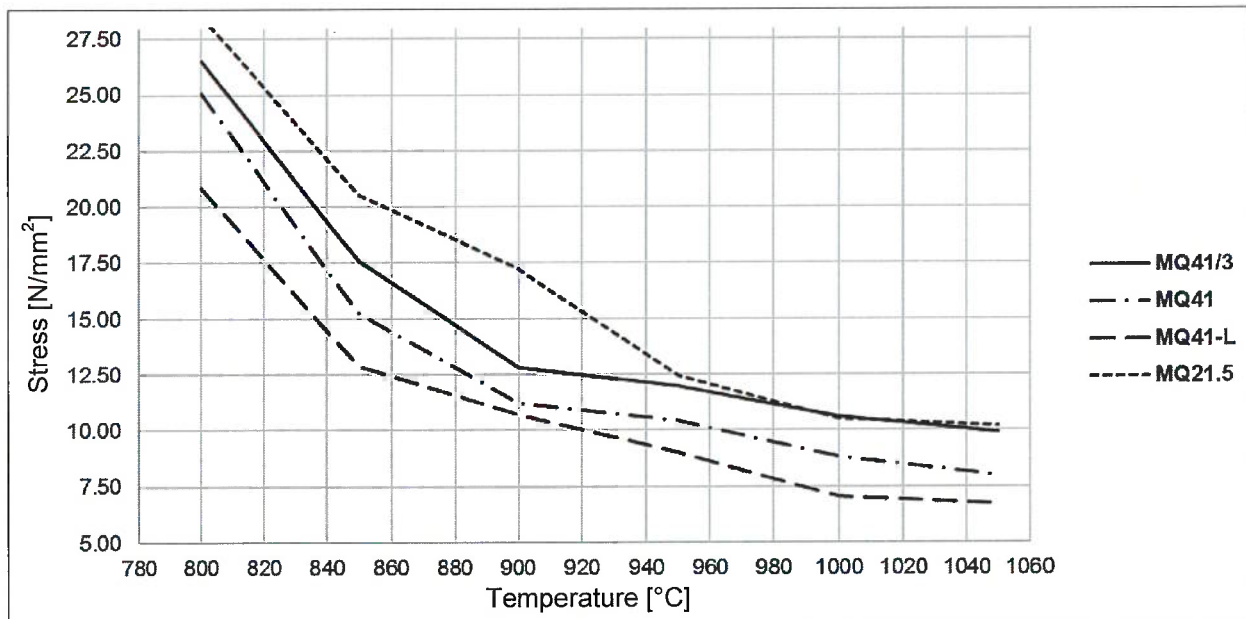

⁴⁾ determined based on unsteady thermal creep tests
^{*)} interpolated values of the channel material stress

Table B6.2: Temperatures⁵⁾ after 30, 60, 90 and 120 minutes according to standard temperature / time curve (STTC)

Time according to STTC [min]	30	60	90	120
Temperature [°C]	842	945	1006	1049

⁵⁾ Furnace temperatures according to STTC;
It can be assumed that the component temperature corresponds to the furnace temperature.

Hilti pipe ring saddle MQA-M10-B, Hilti pipe ring saddle MQA-M12-B and Hilti pipe ring saddle MQA-M16-B

Requirements for performance assessment

Annex B6

Table C1: Characteristic pull-out resistance at ambient temperatures

Pipe ring saddle	Installation channel	Characteristic pull-out resistance	Partial safety coefficient ⁶⁾
		F_{Rk} [kN]	γ_M
MQA-M10-B	MQ-41/3	23.26	2.08
	MQ-41/3 LL		
	MQ-41	15.08	2.15
	MQ-41 D		
	MQ-41-L	7.39	1.76
	MQ-21.5	7.09	1.69
MQA-M12-B	MQ-41/3	20.63	1.84
	MQ-41/3 LL		
	MQ-41	15.92	2.27
	MQ-41 D		
	MQ-41-L	8.02	1.91
	MQ-21.5	6.93	1.65
MQA-M16-B	MQ-41/3	21.70	1.94
	MQ-41/3 LL		
	MQ-41	11.79	1.68
	MQ-41 D		
	MQ-41-L	6.89	1.64
	MQ-21.5	6.29	1.50

⁶⁾ provided that no other national regulations apply

Hilti pipe ring saddle MQA-M10-B, Hilti pipe ring saddle MQA-M12-B and
Hilti pipe ring saddle MQA-M16-B

Characteristic pull-out resistance at ambient temperatures

Annex C

English translation prepared by DIBt

Table D1.1: Parameter of the regression curve $F_{Rk}(t) = c_3 (c_1 + c_2 / t)$ for $\varepsilon_{B,\theta a} \leq 2\%$

Pipe ring saddle	Installation channel	c_1 [-]	c_2 [-]	c_3 [-]	t_{min} [minutes]	t_{max} [minutes]
MQA-M10-B MQA-M12-B	MQ-41/3	695.324	27657.410	0.704	20	150
	MQ-41/3 LL					
	MQ-41	345.949	28750.936	0.713	26	120
	MQ-41 D					
	MQ-41-L	-462.03	35853.38	0.8808	30	33
	MQ-21.5	110.27	19232.88	0.9786	30	48
MQA-M16-B	MQ-41/3	758.416	38174.329	0.844	26	130
	MQ-41/3 LL					
	MQ-41	345.949	28750.936	0.713	26	120
	MQ-41 D					
	MQ-41-L	-462.03	35853.38	0.8808	30	33
	MQ-21.5	110.27	19232.88	0.9786	30	48

Table D1.2: Pull-out resistance $F_{Rk,t}$ at elevated temperatures and $\varepsilon_{B,\theta a} \leq 2\%$

Pipe ring saddle	Installation channel	$F_{Rk,30}$ [N]	$F_{Rk,60}$ [N]	$F_{Rk,90}$ [N]	$F_{Rk,120}$ [N]
MQA-M10-B MQA-M12-B	MQ-41/3	1138	813	705	651
	MQ-41/3 LL				
	MQ-41	930	589	475	NPA ⁷⁾
	MQ-41 D				
	MQ-41-L	646	NPA	NPA	NPA
	MQ-21.5	735	NPA	NPA	NPA
MQA-M16-B	MQ-41/3	1710	1176	998	909
	MQ-41/3 LL				
	MQ-41	930	589	475	NPA
	MQ-41 D				
	MQ-41-L	646	NPA	NPA	NPA
	MQ-21.5	735	NPA	NPA	NPA

⁷⁾ NPA: No performance assessed

Symbols and designation

$\varepsilon_{B,\theta a}$ Channel bending strain at elevated temperatures θ_a
 $F_{Rk,t}$ Resistance after an exposure time t to elevated temperatures
 $F_{Rk}(t)$ Resistance time function at elevated temperatures

Hilti pipe ring saddle MQA-M10-B, Hilti pipe ring saddle MQA-M12-B and
Hilti pipe ring saddle MQA-M16-B

Pull-out resistance with $\varepsilon_{B,\theta a} \leq 2\%$ at elevated temperatures

Annex D1

Table D2: Parameter of the regression curve $F_{Rk}(t) = c_3 (c_1 + c_2 / t)$ for $\varepsilon_{B,0a} > 2\%$

Pipe ring saddle	Installation channel	c_1 [-]	c_2 [-]	c_3 [-]	t_{min} [minutes]	t_{max} [minutes]
MQA-M10-B	MQ-41/3	445.338	18381.52	0.917	26	130
	MQ-41/3 LL					
	MQ-41	255.989	15310.519	0.865	22	120
	MQ-41 D					
	MQ-41-L	102.97	16294.33	0.9344	21	60
	MQ-21.5	406.83	11709.31	0.9900	33	49
MQA-M12-B	MQ-41/3	434.765	24088.663	0.872	26	123
	MQ-41/3 LL					
	MQ-41	255.989	15310.519	0.865	22	120
	MQ-41 D					
	MQ-41-L	102.97	16294.33	0.9344	21	60
	MQ-21.5	406.83	11709.31	0.9900	33	49
MQA-M16-B	MQ-41/3	434.382	19535.05	0.907	22	139
	MQ-41/3 LL					
	MQ-41	255.989	15310.519	0.865	22	120
	MQ-41 D					
	MQ-41-L	NPA ⁷⁾	NPA	NPA	NPA	NPA
	MQ-21.5	NPA	NPA	NPA	NPA	NPA

⁷⁾ NPA: No performance assessed

Symbols and designation see Annex D1

Hilti pipe ring saddle MQA-M10-B, Hilti pipe ring saddle MQA-M12-B and
Hilti pipe ring saddle MQA-M16-B

Pull-out resistance with $\varepsilon_{B,0a} > 2\%$ at elevated temperatures

Annex D2

Table D3: Pull-out resistance $F_{Rk,t}$ at elevated temperatures and $\varepsilon_{B,\theta a} > 2\%$

Pipe ring saddle	Installation channel	$F_{Rk,30}$ [N]	$F_{Rk,60}$ [N]	$F_{Rk,90}$ [N]	$F_{Rk,120}$ [N]
MQA-M10-B	MQ-41/3	970	689	595	549
	MQ-41/3 LL				
	MQ-41	663	442	369	NPA ⁷⁾
	MQ-41 D				
	MQ-41-L	604	NPA	NPA	NPA
	MQ-21.5	789	NPA	NPA	NPA
MQA-M12-B	MQ-41/3	1080	729	613	554
	MQ-41/3 LL				
	MQ-41	663	442	369	NPA
	MQ-41 D				
	MQ-41-L	604	NPA	NPA	NPA
	MQ-21.5	789	NPA	NPA	NPA
MQA-M16-B	MQ-41/3	984	689	590	541
	MQ-41/3 LL				
	MQ-41	663	442	369	NPA
	MQ-41 D				
	MQ-41-L	NPA	NPA	NPA	NPA
	MQ-21.5	NPA	NPA	NPA	NPA

⁷⁾ NPA: No performance assessed

Symbols and designation see Annex D1

Hilti pipe ring saddle MQA-M10-B, Hilti pipe ring saddle MQA-M12-B and
Hilti pipe ring saddle MQA-M16-B

Pull-out resistance with $\varepsilon_{B,\theta a} > 2\%$ at elevated temperatures

Annex D3

Approval body for construction products
and types of construction

Bautechnisches Prüfamt

An institution established by the Federal and
Laender Governments



European Technical Assessment

ETA-18/0133
of 3 July 2018

English translation prepared by DIBt - Original version in German language

General Part

Technical Assessment Body issuing the
European Technical Assessment:

Deutsches Institut für Bautechnik

Trade name of the construction product

Hilti trapeze frame

Product family
to which the construction product belongs

Products related to installation systems supporting
technical equipment for building services such as pipes,
conduits, ducts and cables

Manufacturer

Hilti AG
Feldkircherstraße 100
9494 Schaan
FÜRSTENTUM LIECHTENSTEIN

Manufacturing plant

L1000511, L1038621, L1008864, L1005049, L106663
L1000405, L1000485, L1000446

This European Technical Assessment
contains

18 pages including 14 annexes which form an integral
part of this assessment

This European Technical Assessment is
issued in accordance with Regulation (EU)
No 305/2011, on the basis of

EAD 280016-00-0602

The European Technical Assessment is issued by the Technical Assessment Body in its official language. Translations of this European Technical Assessment in other languages shall fully correspond to the original issued document and shall be identified as such.

Communication of this European Technical Assessment, including transmission by electronic means, shall be in full. However, partial reproduction may only be made with the written consent of the issuing Technical Assessment Body. Any partial reproduction shall be identified as such.

This European Technical Assessment may be withdrawn by the issuing Technical Assessment Body, in particular pursuant to information by the Commission in accordance with Article 25(3) of Regulation (EU) No 305/2011.

Specific Part

1 Technical description of the product

Object of this European Technical Assessment is the Hilti trapeze frame. The Hilti trapeze frame consists of three installation channels made of thin-walled steel profiles. A horizontally aligned MQ-41 D channel is positioned between two vertically aligned MQ-41/3 or MQ-41/3 LL channels and force-fitted to the corners of one another by means of an MQW-S/2 connection bracket and four MQN-B channel connectors each. The MQ-41 D channel consists of two profiles, which are connected in the area of the holes in the back of the channels in a shape-fitting and force-fitting way as a kind of riveted connection. The vertical channels are attached on the upper side to MQP-21-72 rail supports and force-fitted to these by two MQN-B channel connectors each. The suspension height is a maximum of 600 mm and corresponds to the length of the vertical MQ-41/3 or MQ-41/3 LL. The span width corresponds to the clear distance between the vertical channels and can be 700 mm, 1000 mm or 1250 mm. The load is applied centrally to the horizontal MQ-41 D channel by means of an M12 threaded rod, which is fastened to the channel by MQZ-L13 drilled plates arranged in pairs and M12 hexagonal nuts.

Annex A describes the dimensions and materials of the Hilti trapeze frame.

2 Specification of the intended use in accordance with the applicable European Assessment Document (EAD)

The performance given in Section 3 can only be assumed if the Hilti trapeze frame is used in compliance with the specifications and under boundary conditions set out in Annex B. The test and assessment methods on which this European Technical Assessment is based lead to an assumption of a working life of the Hilti trapeze frame of at least 50 years in final use under ambient temperatures in indoor areas. The indications given on the working life cannot be interpreted as a guarantee given by the producer, but are to be regarded only as a means for choosing the right products in relation to the expected economically reasonable working life of the works.

In accordance with the European Assessment Document EAD 280016-00-0602, the product is intended to be used in

- a) installations for the support of sprinkler kits;
- b) installations for the support of other building service elements such as pipes, conduits, ducts and cables.

3 Performance of the product and references to the methods used for its assessment

3.1 Safety in case of fire (BWR 2)

Essential characteristic	Performance
Reaction to fire	Class A1

3.2 Safety and accessibility in use (BWR 4)

Essential characteristic	Performance
Shape	see Annex A
Dimensions	see Annex A
Material	see Annex A
Resistance and deformation at elevated temperatures determined for trapeze frame kits without pipe clamps	see Annex C

4 Assessment and verification of constancy of performance (AVCP) system applied, with reference to its legal base

In accordance with the European Assessment Document EAD 280016-00-0602, the following legal bases apply:

- In case of intended use a) specified in Section 2:
Decision of the commission N° 1996/577/EC:
System 1 applies for the assessment and verification of constancy of performance (AVCP).
- In case of intended use b) specified in Section 2:
Decision of the commission N° 1999/472/EC:
System 3 applies for the assessment and verification of constancy of performance (AVCP).

5 Technical details necessary for the implementation of the AVCP system, as provided for in the applicable EAD

The technical details necessary for the implementation of the system for the assessment and verification of constancy of performance are laid down in the control plan (confidential part of this European Technical Assessment) deposited at Deutsches Institut für Bautechnik.

Issued in Berlin on 3 July 2018 by Deutsches Institut für Bautechnik

BD Dipl.-Ing. Andreas Kummerow
Head of Department

beglaubigt:
Häßler

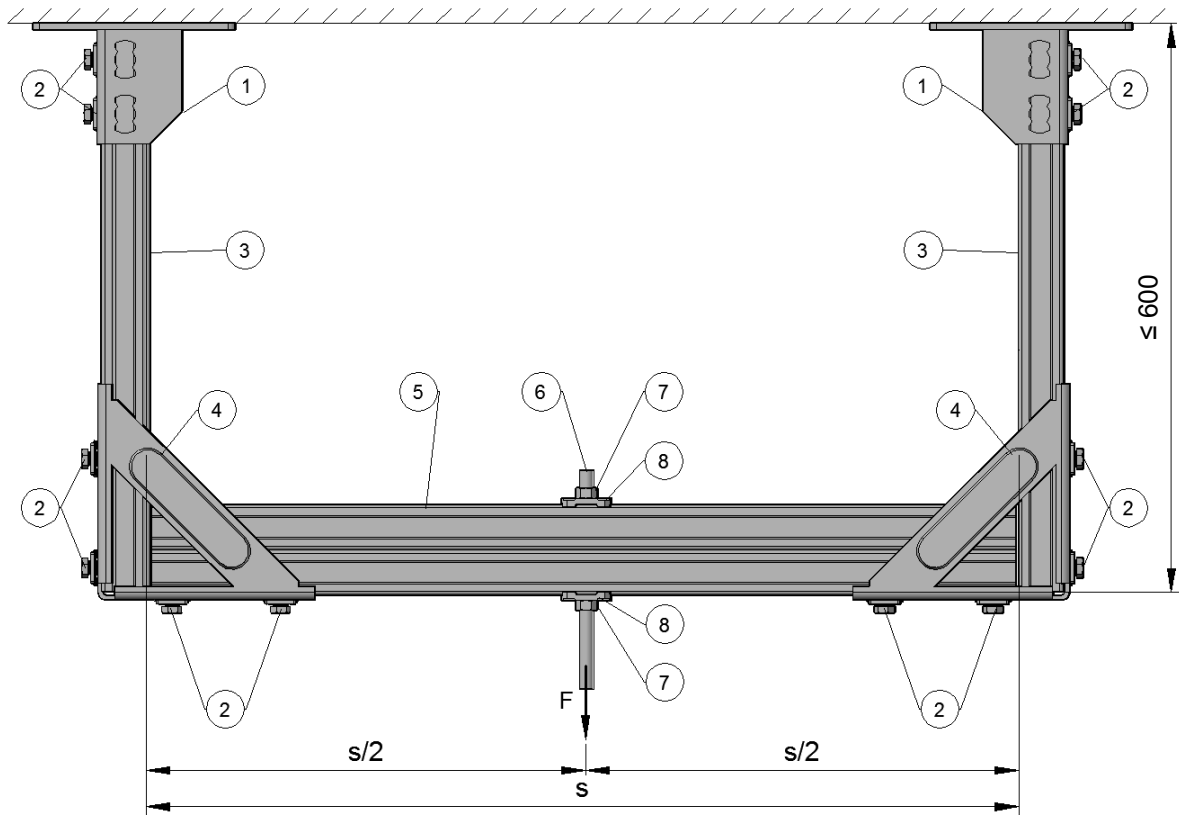

Legend

- 1 Rail support MQP-21-72
- 2 Channel connector MQN-B
- 3 Channel MQ-41/3 or MQ-41/3 LL
- 4 Angle bracket MQW-S/2
- 5 Channel MQ-41 D
- 6 Threaded rod M12
- 7 Hexagonal nut M12
- 8 Drilled plate MQZ-L13

Annex

- A4
- A3
- A2
- A4
- A2
- A4
- A4
- A3

Dimensions in mm

Figure A1: Trapeze frame with clear span $s = 700 \text{ mm}$, 1000 mm , 1250 mm and centric connection for load introduction

electronic copy of the eta by dibt: eta-18/0133

Hilti trapeze frame	Annex A1
Description of product (kit) Dimensions and materials	

Table A2: Dimensions and materials of the channels MQ-41/3, MQ-41/3 LL und MQ-41 D

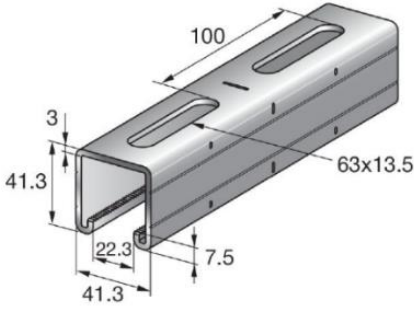
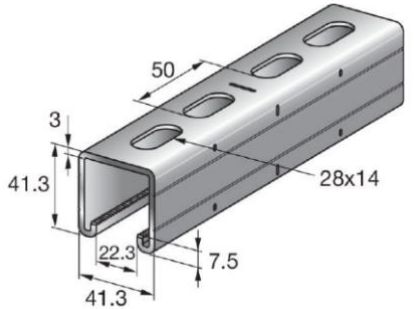
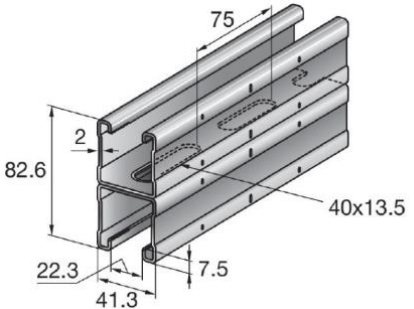
Illustration ¹⁾	Item number	Designation	Length [m]	Materials
	369596	MQ-41/3 3M	3	S250GD+Z275-M-A-C in accordance with EN 10346
	369597	MQ-41/3 6M	6	
	2048102	MQ-41/3 3M LL	3	S250GD+Z275-M-A-C in accordance with EN 10346
	2048103	MQ-41/3 6M LL	6	
 <p>Two profiles of MQ-41 D channel are connected in the area of the holes in the back of the channels in a shape-fitting and force-fitting way as a kind of riveted connection.</p>	369603	MQ-41 D 3m	3	S250GD+Z275-M-A-C in accordance with EN 10346
	369604	MQ-41 D 6m	6	

¹⁾ Dimensions in mm

Hilti trapeze frame

Description of the product (kit)
Dimensions and materials of the components of the kit

Annex A2

Table A3.1: Dimensions and material of the drilled plates

Illustration	Dimensions [mm]	Designation	Item number	Material
		MQZ-L13	2199456	S235JR in accordance with EN 10025-2, zinc coated

Table A3.2: Materials of the components of the channel connector²⁾

Illustration	Item number	Designation	Materials
	2184853	MQN-B	<p>Plate: DD11 in accordance with EN 10111³⁾, zinc coated</p> <p>Nut: S355MC in accordance with EN 10149-2, zinc coated</p> <p>Screw: strength class 8.8 in accordance with EN ISO 898-1, zinc coated</p> <p>Spring element: X10CrNi18-8 in accordance with EN 10270-3</p>

²⁾ Components of the channel connector see ETA-18/0078

³⁾ with $235 \text{ N/mm}^2 \leq R_{eL} \leq 340 \text{ N/mm}^2$, Method of deoxidation: fully killed

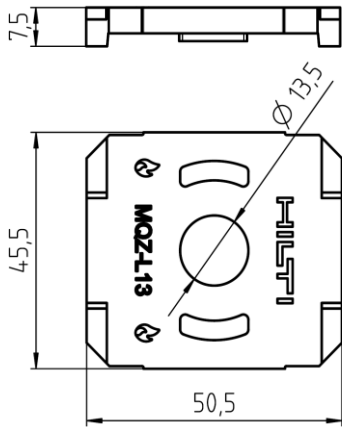
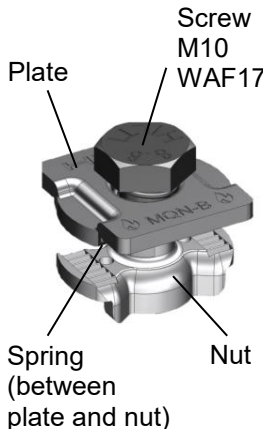
Hilti trapeze frame

Description of the product (kit)
Dimensions and materials of the components of the kit

Annex A3

Table A4.1: Dimensions and material of the threaded rods

Illustration	Designation	Item number	M thread	L [mm]	Material
	AM12x3000 4.8	216421	M12	3000	Strength class 4.8 in accordance with DIN 976-1, zinc coated
	AM12x2000 4.8	216420	M12	2000	
	AM12x1000 4.8	339797	M12	1000	

Table A4.2: Dimensions and material of the hexagonal nuts

Illustration	Designation	Item number	M thread	W [mm]	H [mm]	Material
	M12 hexagonal nut	216467	M12	19	10	Strength class 8 in accordance with ISO 4032, zinc coated

Table A4.3: Dimensions and material of the rail supports

Illustration	Designation	Item number	Material
	MQP-21-72	369651	S235JR in accordance with EN 10025-2, zinc coated

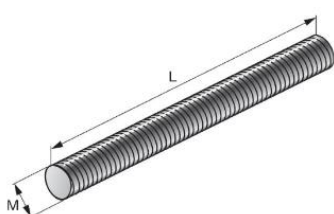
Table A4.4: Dimensions and material of the angle brackets

Illustration	Designation	Item number	Material
	MQW-S/2	369665	S235JR in accordance with EN 10025-2, zinc coated

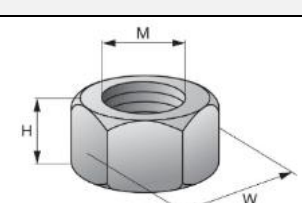
Hilti trapeze frame

Description of the product (kit)
Dimensions and materials of the components of the kit

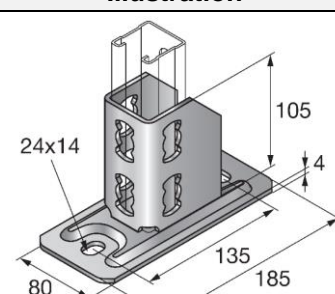
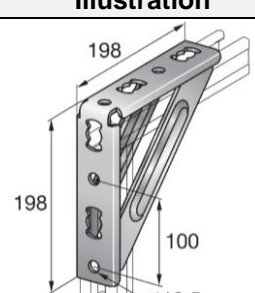
Annex A4

- Hilti trapeze frame is used to transfer building services component loads such as ducts and equipment for sprinklers, water, heating, cooling, ventilation, electrical and other systems. Hilti trapeze frame is performing this loadbearing function at elevated temperatures under the conditions described in Section 2 of this European Technical Assessment.
- Information on resistance and deformation at elevated temperatures applies to static and centric actions on the trapeze frame according to Annex A1. The suspension height of 600 mm corresponds to the length of the vertical MQ-41/3 or MQ-41/3 LL channel. The span width corresponds to the clear distance between the suspended vertical channels.
- The resistance and deformation at elevated temperatures are referring to the boundary conditions of the standard temperature / time curve (STTC) in accordance with EN 1363-1.
- MQZ-L13 drilled plates are always used in pairs in conjunction with zinc coated threaded rods in accordance with DIN 976-1 as per Table A4.1; zinc coated hexagonal nuts in accordance with ISO 4032 as per Table A4.2; and Hilti MQ-41 D installation channels as per Table A2. The hexagonal nuts are to be tightened with a torque of 30 Nm. The threaded rod must protrude by at least 5 mm over the hexagonal nut on the opposite of the load-bearing side (see Figure B1).
- All MQN-B channel connectors must be tightened with a torque of 40 Nm. The longitudinal axes of the MQN-B nut and the channel are perpendicular to each other after assembly with centric position of the screw between the parallel flanges of the channel.
- The channels are cut to length centrally between the longholes or the roundholes at the marking. The cut channel lies within a range of 2 mm from both sides of the marking.
- The fastening of the base connector to the base material is made with appropriate anchors. The anchoring used with the base material must have a fireproof certificate.
- Prior to installation, it must be ensured that the component to be supported by the trapeze frame, the anchoring of the trapeze frame to the base material and the base material itself are suitable to withstand the resistance values of the trapeze frame and that they have a fireproof certificate.
- Installation must be carried out by trained personnel and under the supervision of the site manager. The general assembly instructions of the manufacturer apply.

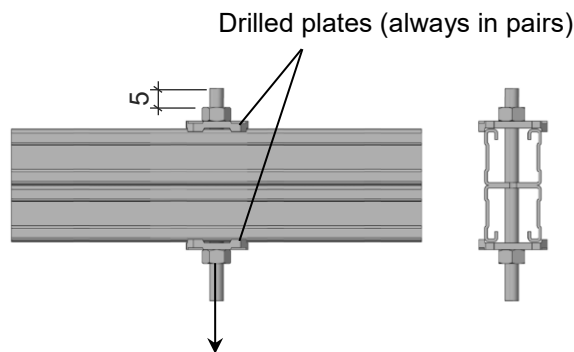

Figure B1: Direction of force and arrangement of the drilled plates

Hilti trapeze frame

Requirements for performance assessment

Annex B1

Table B2: Section properties of installation channels MQ-41/3, MQ-41/3 LL und MQ-41 D

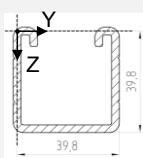
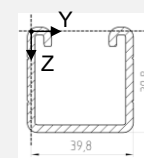
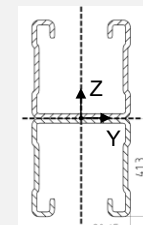
Description	Symbol	MQ-41/3	MQ-41/3 LL	MQ-41 D	Unit
					
Classification cross section in accordance with EN 1993-1-1	-	3	3	3	-
Cross section areas	A	375.88	379.93	545.97	mm ²
	A _{tot}	375.88	379.93	545.97	mm ²
Shear areas	A _y	48.69	54.43	66.37	mm ²
	A _z	195.47	194.59	197.58	mm ²
Centroid position	y _{C,0}	19.15	19.15	0.00	mm
	z _{C,0}	20.57	20.76	0.00	mm
Moments of inertia	I _y	76963.50	78224.80	323585.00	mm ⁴
	I _z	107949.00	108011.00	154070.00	mm ⁴
Inclination of principal axes	α	90.00	90.00	0.00	°
Polar moments of inertia	I _p	184913.00	186236.00	477656.00	mm ⁴
	I _{p,M}	778900.00	780561.00	477656.00	mm ⁴
Radii of gyration	i _y	14.31	14.35	24.35	mm
	i _z	16.95	16.86	16.80	mm
Polar radii of gyration	i _p	22.18	22.14	29.58	mm
	i _{p,M}	45.52	45.33	29.58	mm
Warping radius of gyration	i _{ω,M}	7.02	7.02	17.32	mm
Torsional constant	J	848.88	856.29	575.03	mm ⁴
Secondary torsional constant	J _s	105319.00	105394.00	91246.30	mm ⁴
Location of the shear center	y _{M,0}	19.15	19.15	0.00	mm
	z _{M,0}	60.32	60.31	0.00	mm
	y _M	0.00	0.00	0.00	mm
	z _M	39.75	39.55	0.00	mm
Warping constants	I _{ω,C}	2.09277E+08	2.07678E+08	1.43225E+08	mm ⁶
	I _{ω,M}	38387600	38417600.00	1.43225E+08	mm ⁶
	r _{ω,M}	0.00	0.00	0.00	-
Section moduli	S _{y,max}	4002.48	4108.45	7834.29	mm ³
	S _{y,min}	-3487.10	-3514.15	-7833.74	mm ³
	S _{z,max}	5227.58	5230.56	7460.71	mm ³
	S _{z,min}	-5277.58	-5230.56	-7460.71	mm ³
Torsional section modulus	S _t	282.96	285.43	287.51	mm ³
Max. plastic bending moment	M _{pl,y,k}	NPA ³⁾	NPA	NPA	kNm
	M _{pl,z,k}	NPA	NPA	NPA	kNm
Max. plastic section moduli	Z _y	NPA	NPA	NPA	mm ³
	Z _z	NPA	NPA	NPA	mm ³
Plastic shear areas	A _{pl,y}	NPA	NPA	NPA	mm ²
	A _{pl,z}	NPA	NPA	NPA	mm ²
Area bisecting axis position	f _{y,0}	NPA	NPA	NPA	mm
	f _{z,0}	NPA	NPA	NPA	mm
Plastic shear forces	V _{pl,y,k}	NPA	NPA	NPA	kN
	V _{pl,z,k}	NPA	NPA	NPA	kN
Plastic axial force	N _{pl,k}	NPA	NPA	NPA	kN
Buckling curves	BC _y	c	c	c	-
	BC _z	c	c	c	-

³⁾ NPA: No performance assessed

Hilti trapeze frame

Requirements for performance assessment

Annex B2

Table C1.1: Resistance of the trapeze frame with centric single load according to Annex A1 at elevated temperatures: Parameter of the regression curve $F_{Rk}(t) = c_3(c_1 + c_2/t)$

Clear span s [mm]	c_1	c_2	c_3	t_{min} [Minutes]	t_{max} [Minutes]
700	265.723	93772.378	0.86796	30	130
1000	-269.244	111054.96	0.89370	30	132
1250	-174.179	88162.761	0.8910	30	132

Table C1.2: Resistance $F_{Rk,t}$ of the trapeze frame with centric single load according to Annex A1 at elevated temperatures after $t = 30, 60, 90$ und 120 minutes

Clear span s [mm]	$F_{Rk,30}$ [N]	$F_{Rk,60}$ [N]	$F_{Rk,90}$ [N]	$F_{Rk,120}$ [N]
700	2944	1587	1135	909
1000	3068	1414	862	586
1250	2463	1154	718	499

Symbols and designation

δ	Deformation
$\delta_{max,t}$	Maximum deformation after an exposure time $\leq t$ minutes to elevated temperatures
$F_{Rk,30}(\delta)$	Load displacement function for an exposure time $t = 30$ minutes to elevated temperatures
$F_{Rk,t}$	Resistance after an exposure time t to elevated temperatures
$F_{Rk}(t)$	Resistance time function at elevated temperatures

Hilti trapeze frame

Resistance at elevated temperatures

Annex C1

Table C2.1: Load displacement function and deformation of the trapeze frame with centric single load according to Annex A1 at elevated temperatures. Parameter of the load displacement curve $F_{Rk,30}(\delta) = a_3 (a_1 + \delta^2)$

Clear span s [mm]	a_1	a_2	a_3	δ [mm]
700	624.4191	0.271158	0.630376	$4 \leq \delta \leq 217$
1000	99.19606	0.598566	0.721039	$30 \leq \delta \leq 379$
1250	91.69105	0.581169	0.700153	$28 \leq \delta \leq 420$

Table C2.2: Load displacement values $F_{Rk,30}(\delta)$ and deformation of the trapeze frame with centric single load according to Annex A1 at elevated temperatures

δ [mm]	Clear span s		
	700 mm	1000 mm	1250 mm
	$F_{Rk,30}(\delta)$ [N]		
50	1137	744	624
100	1372	1126	933
150	1532	1435	1181
200	1656	1705	1396
250	-	1949	1589
300	-	2174	1767
350	-	2384	1932

Table C2.3: Maximum displacement of the trapeze frame with centric single load according to Annex A1 at elevated temperatures until time t

$\delta_{max,t}$ [mm]	Clear span s		
	700 mm	1000 mm	1250 mm
$\delta_{max,60}$	303	395	430
$\delta_{max,90}$	303	395	430
$\delta_{max,120}$	303	395	430

Symbols and designation see Annex C1

Hilti trapeze frame	Annex C2
Deformation at elevated temperatures	

English translation prepared by DIBt

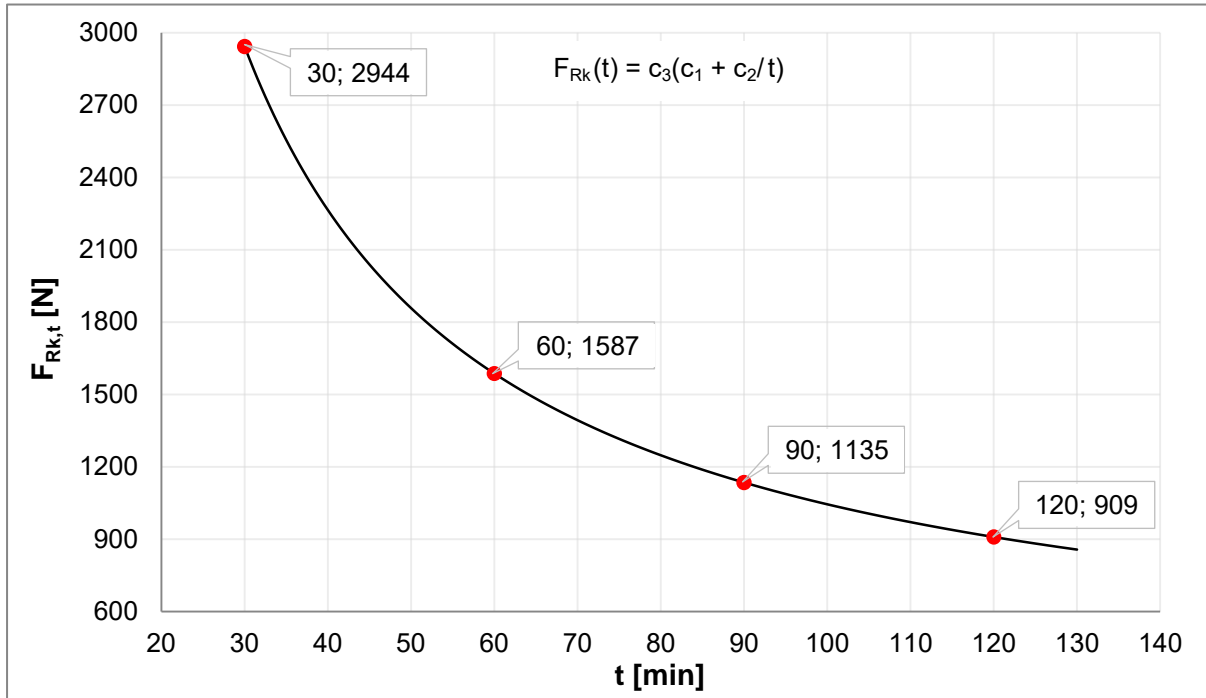

Figure C3.1: Resistance at elevated temperatures for trapeze frame with clear span of 700 mm

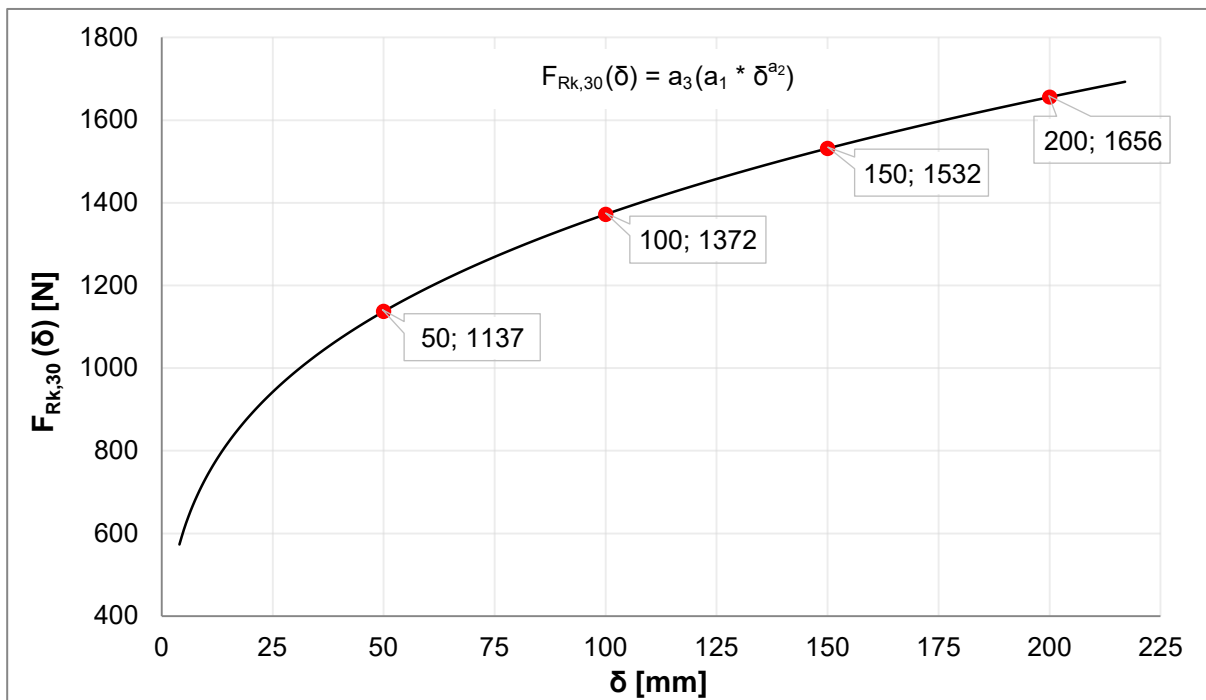

Figure C3.2: Deformation when exposed to elevated temperatures until 30 minutes for trapeze frame with clear span of 700 mm

Symbols and designation see Annex C1

Hilti trapeze frame	Annex C3
Resistance and deformation at elevated temperatures	

electronic copy of the eta by dibt: eta-18/0133

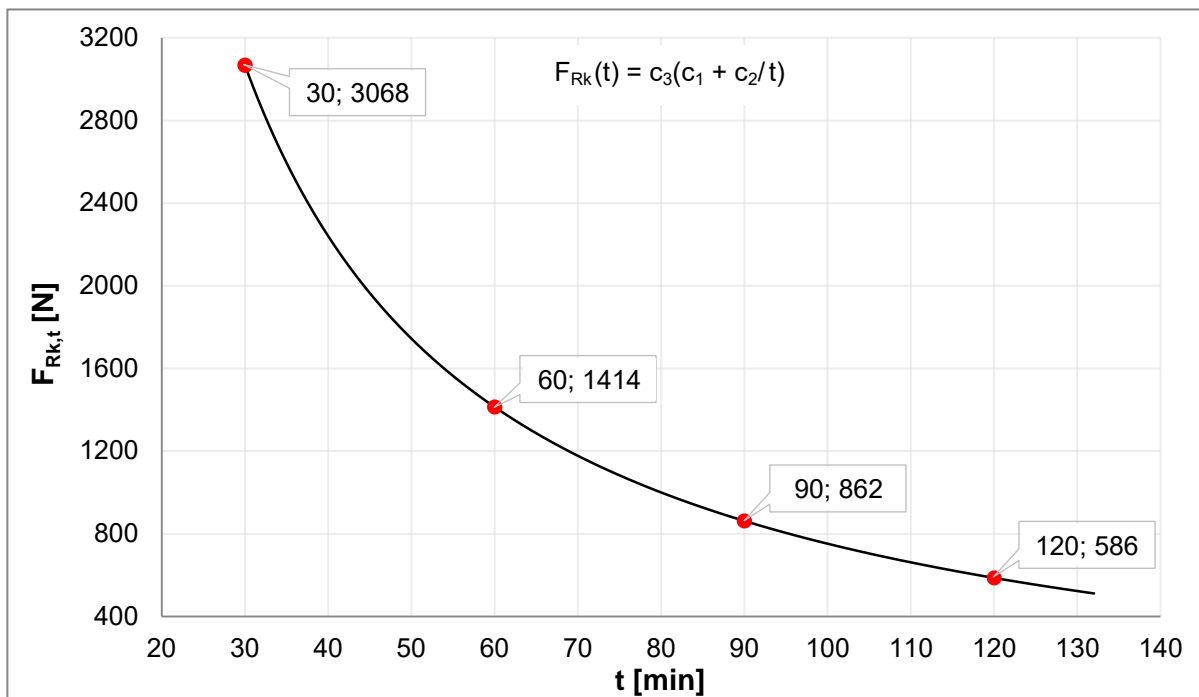

Figure C4.1: Resistance at elevated temperatures for trapeze frame with clear span of 1000 mm

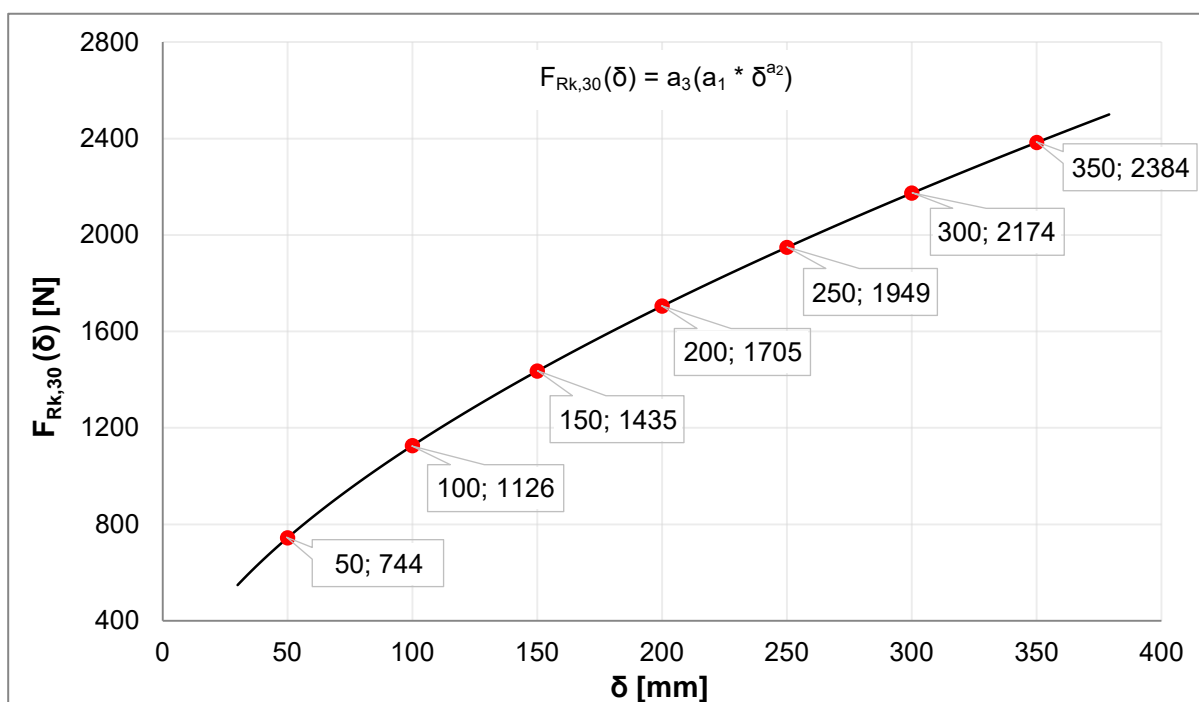

Figure C4.2: Deformation when exposed to elevated temperatures until 30 minutes for trapeze frame with clear span of 1000 mm

Symbols and designation see Annex C1

Hilti trapeze frame

Resistance and deformation at elevated temperatures

Annex C4

English translation prepared by DIBt

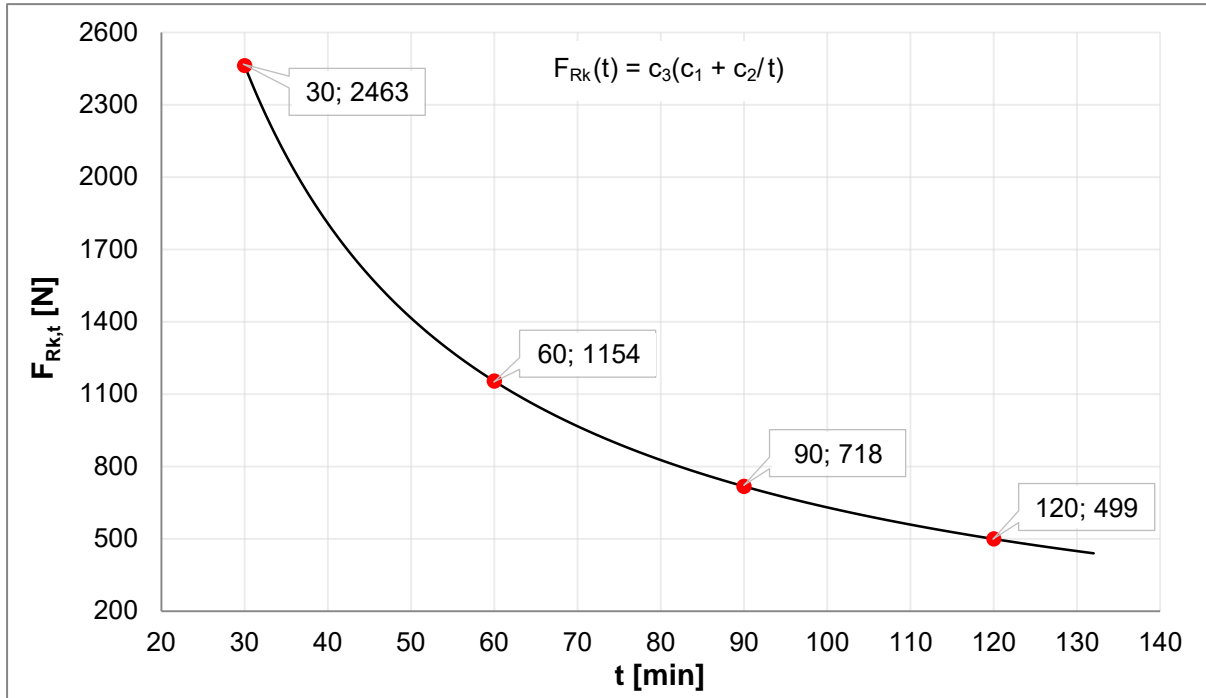

Figure C5.1: Resistance at elevated temperatures for trapeze frame with clear span of 1250 mm

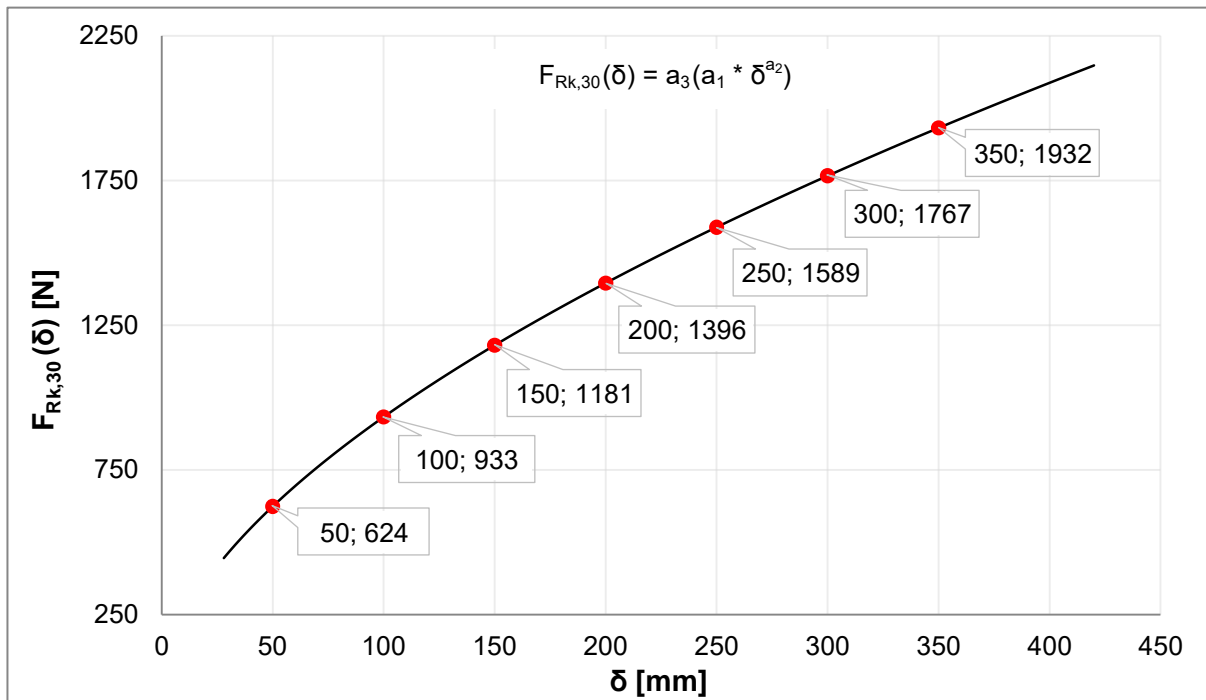
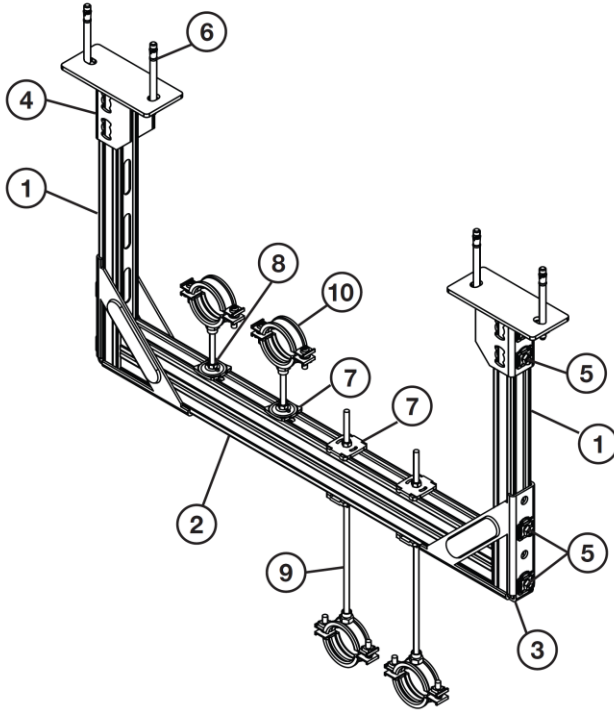

Figure C5.2: Deformation when exposed to elevated temperatures until 30 minutes for trapeze frame with clear span of 1250 mm

Symbols and designation see Annex C1

electronic copy of the eta by dibt: eta-18/0133

Hilti trapeze frame	Annex C5
Resistance and deformation at elevated temperatures	



Bill of material / Stückliste						
Part of typical/ Applikationselement	Ref.	Opt.	Item no. / Artikel Nr.	Description / Bezeichnung		
Channel / Schiene	1		369596	MQ-41/3 3m channel*		
	1		2048102	MQ-41/3 LL 3m channel*		
	2		369603	MQ-41 D 3m channel*		
	Structure / Aufbau	3		369655	MQW-S/2 angle	
		4		369651	MQP-21-72 base plate	
Fixation / Befestigung		5		2184853	MQN-B pushbutton	
		6	A	2107848	HST2 M12x105 10 stud anchor	
		6	B	2105718	HST3 M12x105 30/10 stud anchor	
6	C	2079912	HUS3-H 10x70 15/-/-			
Pipe Fixation / Rohr- fixierung	M10	7	A	2199452	MQA-M10-B piping saddle	
		7	B	2199455	MQZ-L11 bored plate	
		8		216466	M10 hexagon nut	
	M12	7	A	2199453	MQA-M12-B piping saddle	
		7	B	2199456	MQZ-L13 bored plate	
		8		216467	M12 hexagon nut	
	M16	7		2199454	MQA-M16-B piping saddle	
		8		216468	M16 hexagon nut	
		9		216422	AM16x1000 4.8 threaded rod**	
	Pipe Ring / Rohrschelle	M10/ M12/ M16	10		20843	MP-MI (from 3/8" to 244.5C, with M10, 12, 16)
			10		20898	

* other lengths of the channels also possible / * andere Schienenlängen auch möglich
** Threaded rod available in 1,2 & 3 meters / **Gewindestange erhältlich in 1,2 & 3 Meter

Assembly Instructions / Montagehinweise

1 / 2

Please use the Threaded rod either in closed long holes or closed round holes in the channel
Verwendung von Gewindestangen nur durch geschlossene Langlöcher bzw. Rundlöcher der Schiene

3

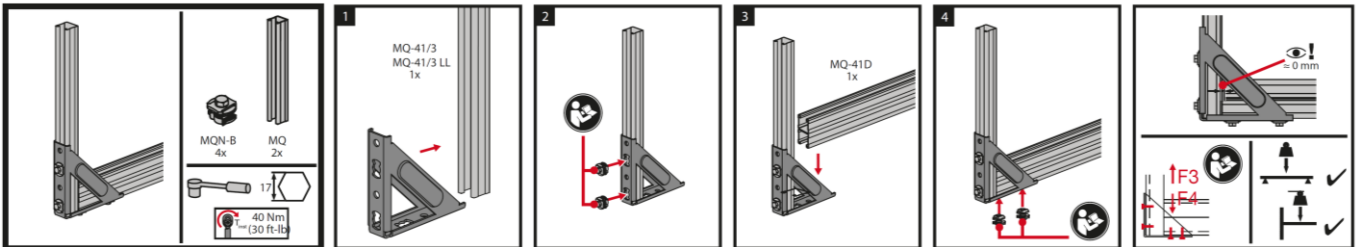

Hilti trapeze frame

General assembly instructions

Annex D1
(informative)

4

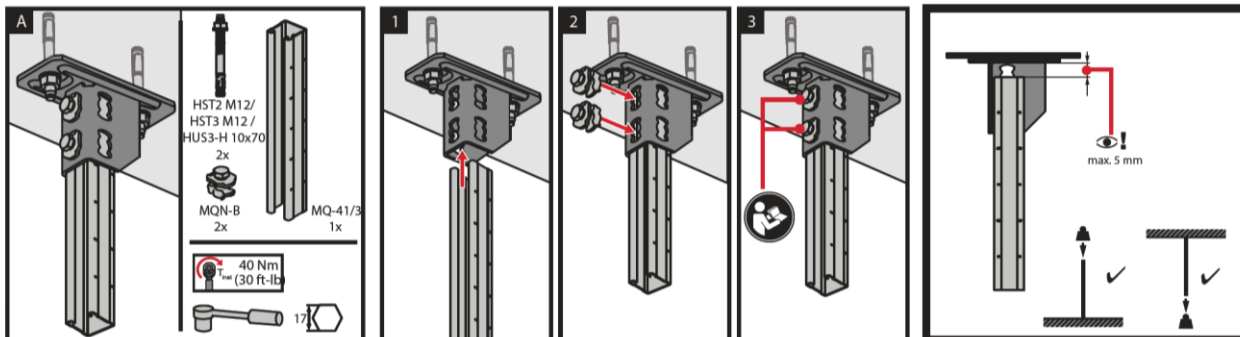

5

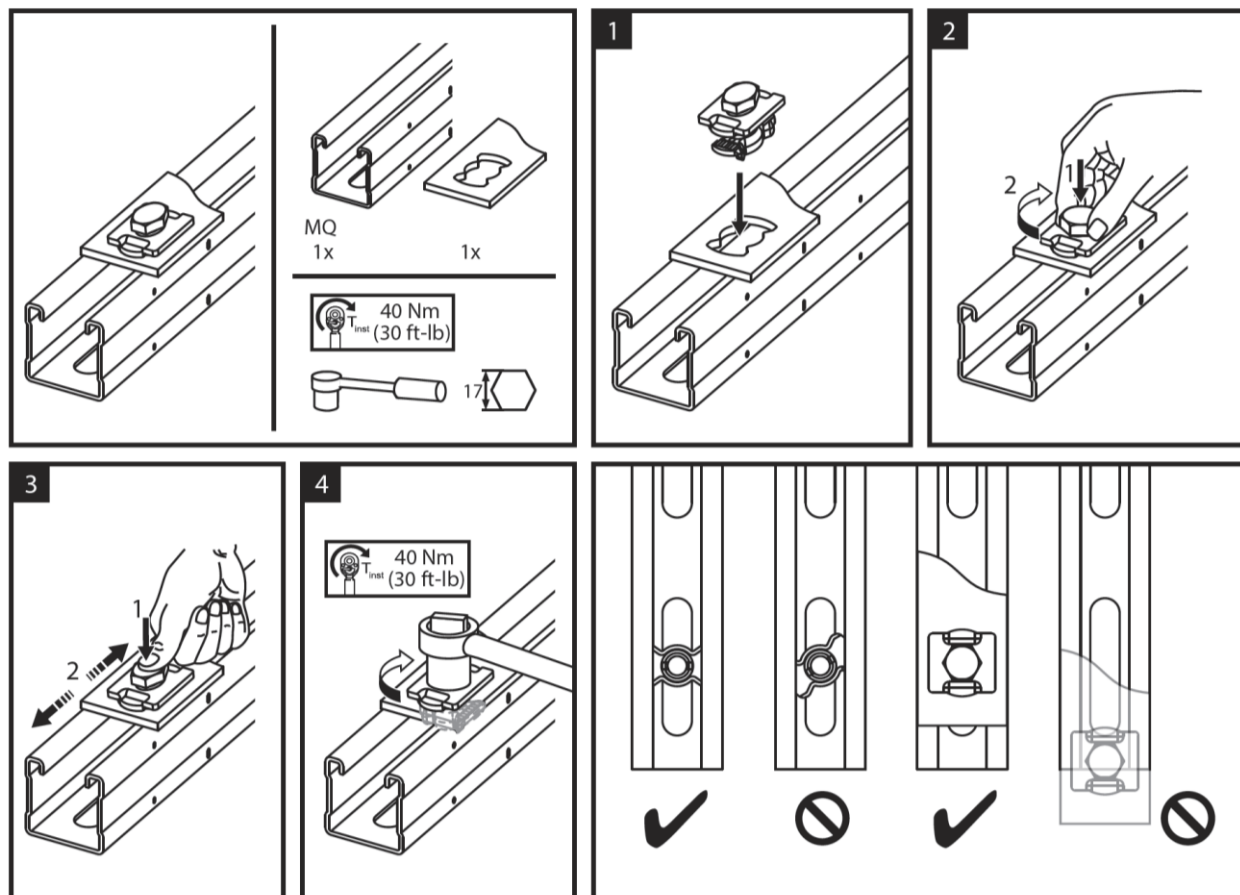

electronic copy of the eta by dibt: eta-18/0133

Hilti trapeze frame

General assembly instructions

Annex D2
(informative)

English translation prepared by DIBt

7 / 8 / 9 Not Part of this ETA / kein Bestandteil dieser ETA

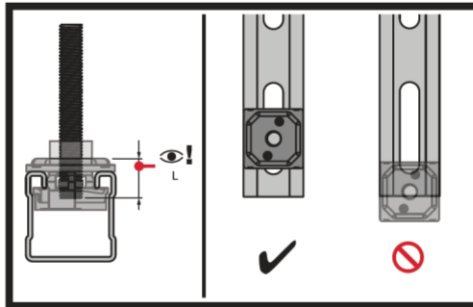
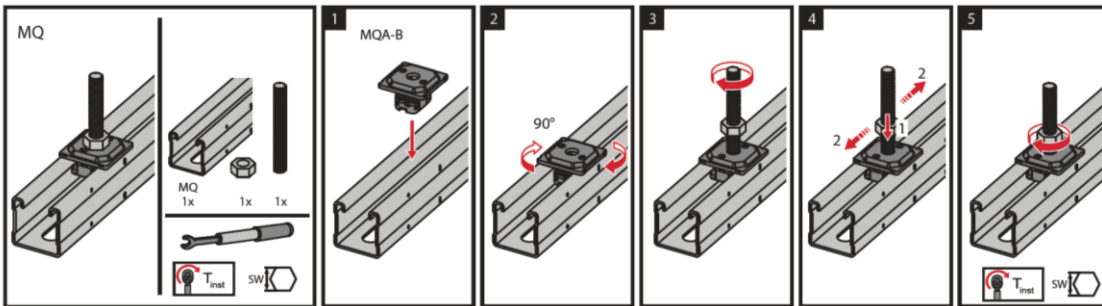

or / oder

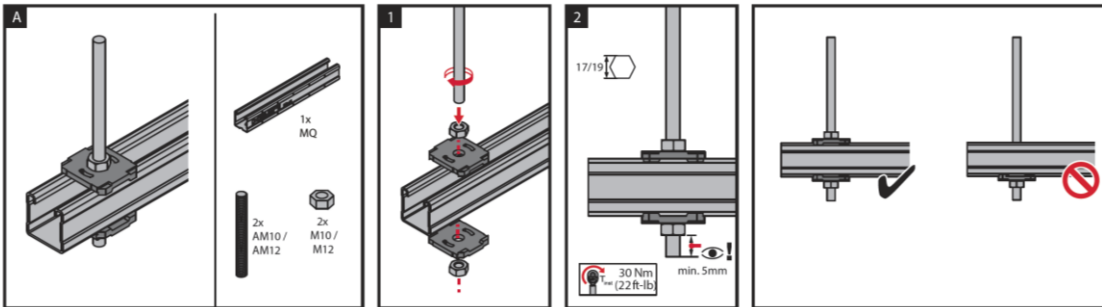

10 Not Part of this ETA / kein Bestandteil dieser ETA

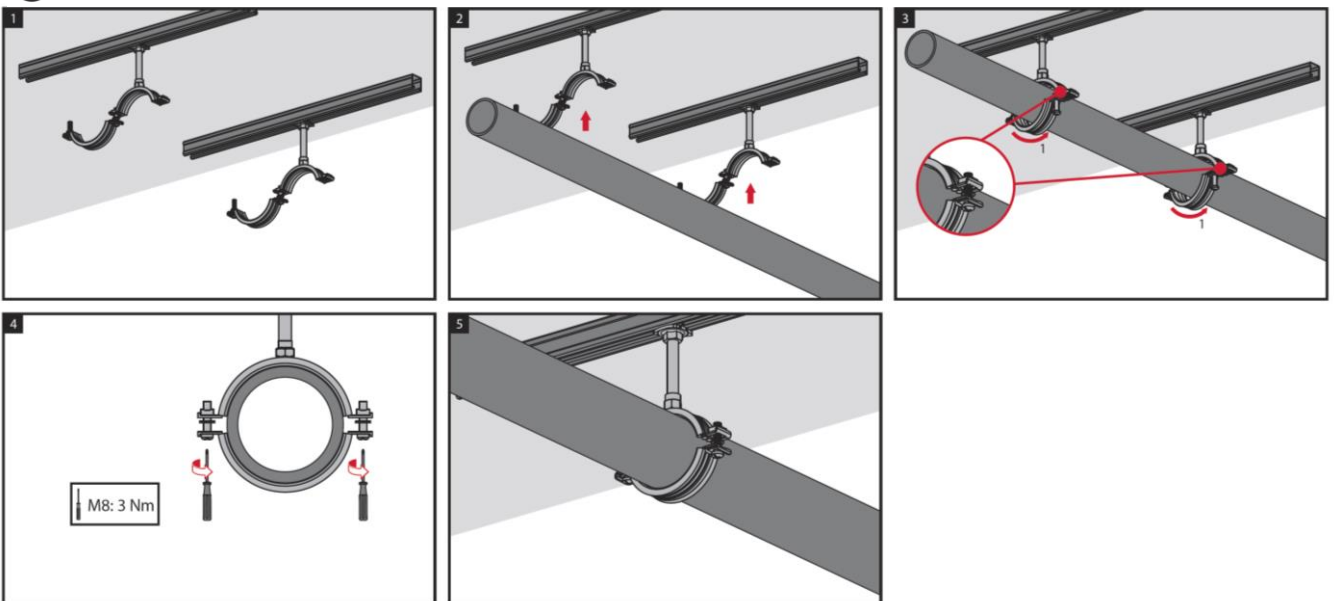

Hilti trapeze frame

General assembly instructions

Annex D3
(informative)

Approval body for construction products
and types of construction

Bautechnisches Prüfamt

An institution established by the Federal and
Laender Governments



European Technical Assessment

ETA-18/0177
of 20 July 2018

English translation prepared by DIBt - Original version in German language

General Part

Technical Assessment Body issuing the
European Technical Assessment:

Deutsches Institut für Bautechnik

Trade name of the construction product

Hilti bracket MQK-41/3/300 with load introduction
components

Product family
to which the construction product belongs

Products related to installation systems supporting
technical equipment for building services such as pipes,
conduits, ducts and cables

Manufacturer

HILTI Corporation
Feldkircherstraße 100
9494 SCHAAN
FÜRSTENTUM LIECHTENSTEIN

Manufacturing plant

L 1000511
L 1000446
L 1000405
L 106663
L 1069983

This European Technical Assessment
contains

11 pages including 7 annexes which form an integral part
of this assessment

This European Technical Assessment is
issued in accordance with Regulation (EU)
No 305/2011, on the basis of

EAD 280016-00-0602

European Technical Assessment

ETA-18/0177

English translation prepared by DIBt

Page 2 of 11 | 20 July 2018

The European Technical Assessment is issued by the Technical Assessment Body in its official language. Translations of this European Technical Assessment in other languages shall fully correspond to the original issued document and shall be identified as such.

Communication of this European Technical Assessment, including transmission by electronic means, shall be in full. However, partial reproduction may only be made with the written consent of the issuing Technical Assessment Body. Any partial reproduction shall be identified as such.

This European Technical Assessment may be withdrawn by the issuing Technical Assessment Body, in particular pursuant to information by the Commission in accordance with Article 25(3) of Regulation (EU) No 305/2011.

Specific part

1 Technical description of the product

Object of this European Technical Assessment is the Hilti bracket MQK-41/3/300 with load introduction components. The MQK-41/3/300 bracket consists of a steel baseplate with three elongated holes and a welded-on, thin-walled steel channel profile with parallel flanges and a connecting web. The elongated holes in the steel plate are arranged centrally on their longitudinal axis. The edges of the channel flanges are folded over. The flange faces are grooved to enable matching channel fixtures to be firmly interlocked to the channel. The channel web is slotted at regular intervals. Loads are applied to the channel profile of the bracket using the MQA-M12-B pipe ring saddle in conjunction with M12 threaded rod and M12 hexagonal nut. The MQA-M12-B pipe ring saddle consists of a nut and a steel clamping plate connected to each other with a spring element made of PET. The pipe ring saddle has a centred round opening. The opening in the nut is for receiving the threaded rod.

Annex A describes the dimensions and materials of the Hilti bracket MQK-41/3/300 with load introduction components.

2 Specification of the intended use in accordance with the applicable European Assessment Document (EAD)

The performance given in Section 3 can only be assumed if the Hilti bracket MQK-41/3/300 with load introduction components is used in compliance with the specifications and under boundary conditions set out in Annex B. The test and assessment methods on which this European Technical Assessment is based lead to an assumption of a working life of the Hilti bracket MQK-41/3/300 with load introduction components of at least 50 years in final use under ambient temperatures in indoor areas. The indications given on the working life cannot be interpreted as a guarantee given by the producer, but are to be regarded only as a means for choosing the right products in relation to the expected economically reasonable working life of the works.

In accordance with the European Assessment Document EAD 280016-00-0602, the product is intended to be used in

- a) installations for the support of sprinkler kits;
- b) installations for the support of other building service elements such as pipes, conduits, ducts and cables.

3 Performance of the product and references to the methods used for its assessment

3.1 Safety in case of fire (BWR 2)

Essential characteristic	Performance
Reaction to fire: Steel	Class A1
Reaction to fire: Plastic parts	not relevant for fire growth in accordance with TR021 and therefore do not need to be classified

3.2 Safety and accessibility in use (BWR 4)

Essential characteristic	Performance
Shape	see Annex A
Dimensions	see Annex A
Material	see Annex A
Resistance and deformation at elevated temperatures determined for non-suspended cantilever kits without pipe clamps	see Annex C

4 Assessment and verification of constancy of performance (AVCP) system applied, with reference to its legal base

In accordance with the European Assessment Document EAD 280016-00-0602, the following legal bases apply:

- In case of intended use a) specified in Section 2:
Decision of the commission N° 1996/577/EC:
System 1 applies for the assessment and verification of constancy of performance (AVCP).
- In case of intended use b) specified in Section 2:
Decision of the commission N° 1999/472/EC:
System 3 applies for the assessment and verification of constancy of performance (AVCP).

5 Technical details necessary for the implementation of the AVCP system, as provided for in the applicable EAD

The technical details necessary for the implementation of the system for the assessment and verification of constancy of performance are laid down in the control plan (confidential part of this European Technical Assessment) deposited at Deutsches Institut für Bautechnik.

Issued in Berlin on 20 July 2018 by Deutsches Institut für Bautechnik

BD Dipl.-Ing. Andreas Kummerow
Head of Department

beglaubigt:
Häßler

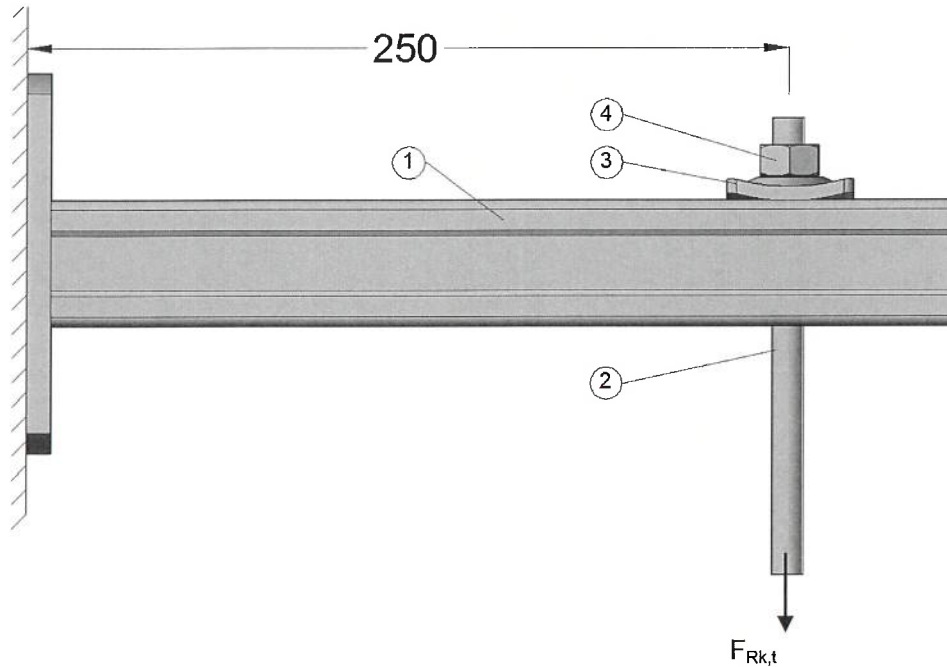

Legend

- 1 Bracket MQK-41/3/300
- 2 Threaded rod M12
- 3 Pipe ring saddle MQA-M12-B
- 4 Hexagon nut M12

Annex

- A2
- A2
- A3
- A2

Dimensions in mm

Figure A1: Hilti bracket MQK-41/3/300 with load introduction components

Hilti bracket MQK-41/3/300 with load introduction components

Description of product (kit)
 Dimensions and materials

Annex A1

English translation prepared by DIBt

Table A2.1: Dimensions and materials of the bracket MQK-41/3/300¹⁾

Illustration	Designation	Item number	L [mm]	Material channel	Material plate
	MQK-41/3/300	370595	300	S235JR in accordance with EN 10025-2, zinc coated	S235JR in accordance with EN 10025-2, zinc coated

¹⁾ Bracket MQK-41/3/300 see ETA-18/0245

Table A2.2: Dimensions and materials of the threaded rods

Illustration	Designation	Item number	M thread	L [mm]	Material
	AM12x3000 4.8	216421	M12	3000	Strength class 4.8 in accordance with DIN 976-1, zinc coated
	AM12x2000 4.8	216420	M12	2000	
	AM12x1000 4.8	339797	M12	1000	

Table A2.3: Dimensions and materials of the hexagon nut

Illustration	Designation	Item number	M thread	W [mm]	H [mm]	Material
	M12 hexagon nut	216467	M12	19	10	Strength class 8 in accordance with ISO 4032, zinc coated

Dimensions in mm

Hilti bracket MQK-41/3/300 with load introduction components

Description of product (kit)
Dimensions and materials of the components of the kit

Annex A2

Table A3.1: Dimensions and materials of the pipe ring saddle

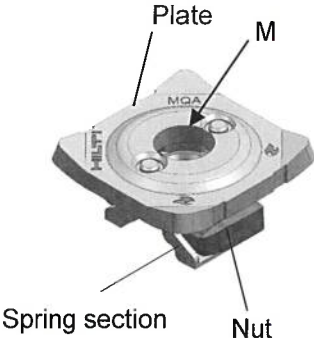
Illustration	Item number	Designation	M [mm]	Materials
	2199453	MQA-M12-B	12	<p>Plate: DD11 in accordance with EN 10111²⁾, zinc coated</p> <p>Nut: C4C in accordance with EN 10263-2, zinc coated</p> <p>Spring section: PET</p>

²⁾ with $235 \text{ N/mm}^2 \leq R_{eL} \leq 340 \text{ N/mm}^2$, Method of deoxidation: fully killed

Table A3.2: Dimensions of the components of the pipe ring saddle MQA-M12-B

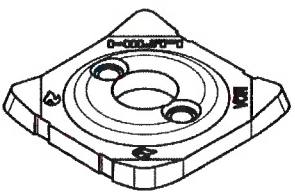
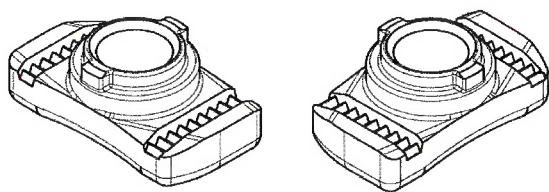
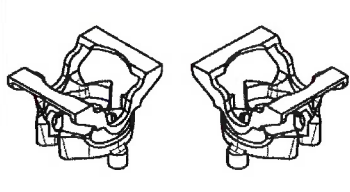
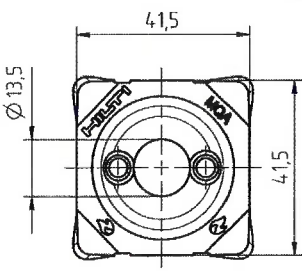
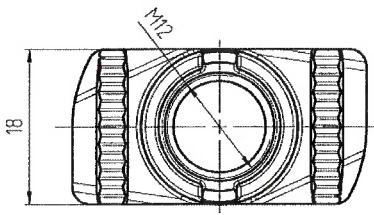
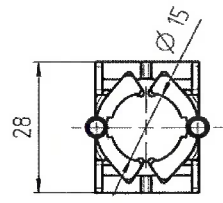
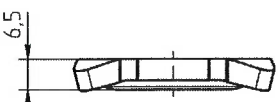
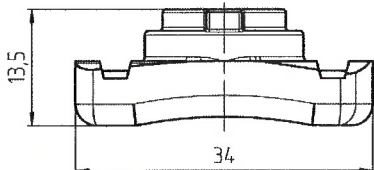
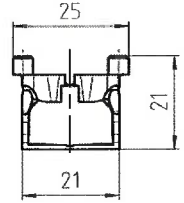
Plate	Nut	Spring section
		
		
		

Dimensions in mm

Hilti bracket MQK-41/3/300 with load introduction components

Description of product (kit)
Dimensions and materials of the components of the kit

Annex A3

English translation prepared by DIBt

- Hilti bracket MQK-41/3/300 with load introduction components is used to transfer building services component loads such as ducts and equipment for sprinklers, water, heating, cooling, ventilation, electrical and other systems. Hilti bracket MQK-41/3/300 with load introduction components is performing this loadbearing function under the conditions described in Section 2 of this European Technical Assessment.
- The resistance at elevated temperatures applies for static and centric actions on the threaded rod according to Annex A1.
- The bracket is attached directly to the base material with the channel cross-section facing upwards. The fastening of the base connector to the base material is made with appropriate anchors. The anchoring used with the base material must be suitable and have a fireproof certificate.
- The resistance and deformation at elevated temperatures are referring to the boundary conditions of the standard temperature / time curve (STTC) in accordance with EN 1363-1.
- Prior to installation, it must be ensured that the component to be supported by the bracket, the anchoring of the bracket to the base material and the base material itself are suitable to withstand the resistance values of the installation system and that they have a fireproof certificate.
- Installation must be carried out by trained personnel and under the supervision of the site manager. The general assembly instructions of the manufacturer apply.
- The installation of the pipe ring saddle and the threaded rod is carried out according to the following principles:

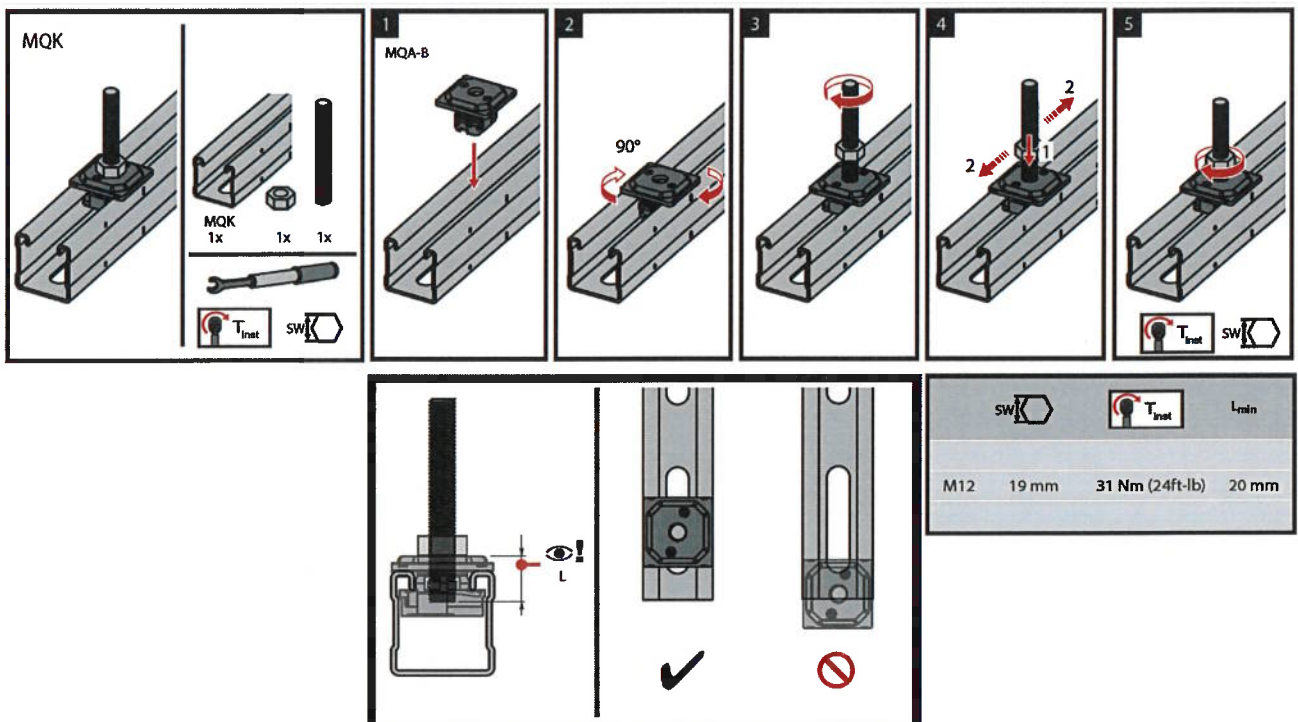

Hilti bracket MQK-41/3/300 with load introduction components

Requirements for performance assessment

Annex B

Table C1.1: Resistance $F_{Rk,t}$ of the bracket MQK-41/3/300 with load introduction components according to Annex A1 at elevated temperatures

$F_{Rk,30}$ [N]	$F_{Rk,60}$ [N]	$F_{Rk,90}$ [N]	$F_{Rk,120}$ [N]
284	NPA ³⁾	NPA	NPA

³⁾ NPA: No performance assessed

Table C1.2: Resistance of the bracket MQK-41/3/300 with load introduction components according to Annex A1 at elevated temperatures. Parameter of the regression curve $F_{Rk}(t) = c_3 (c_1 + c_2 / t)$ [N]

c_1 [-]	c_2 [-]	c_3 [-]	t_{min} [minutes]	t_{max} [minutes]
20.245	8503.067	0.936782	30	44

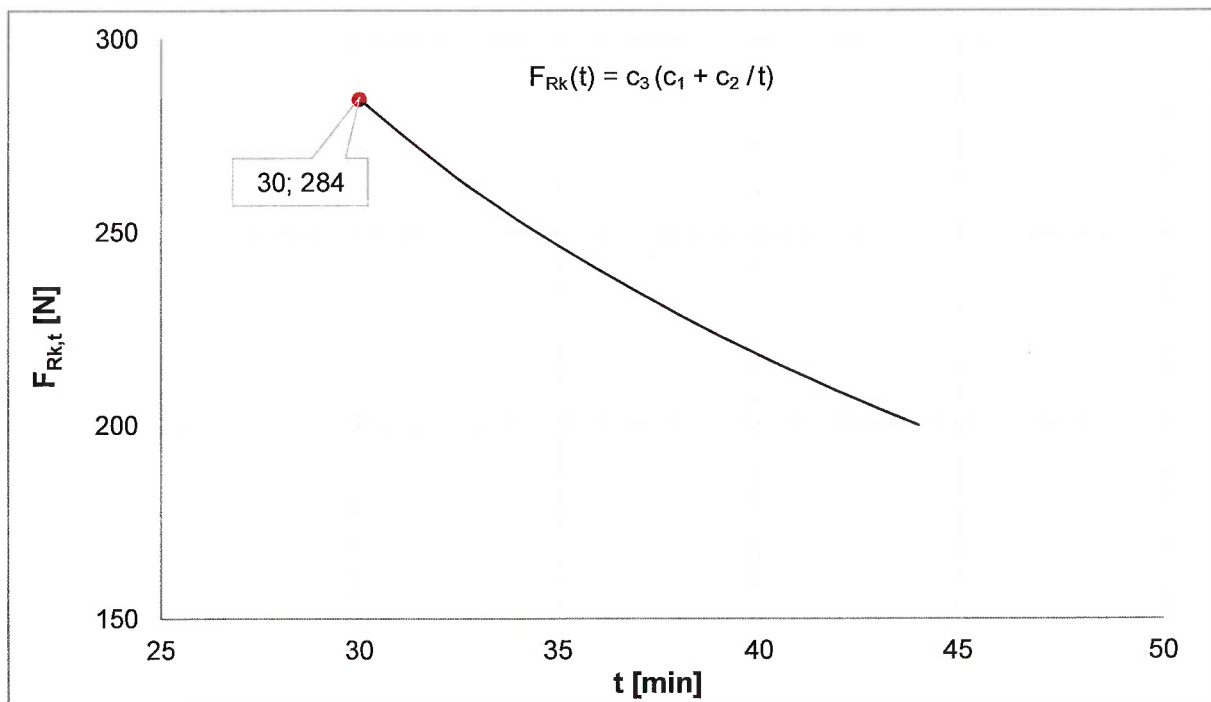

Figure C1: Regression curve according to Table C1.2

Designation

$F_{Rk,t}$ Resistance after an exposure time t to elevated temperatures
 $F_{Rk}(t)$ Resistance time function at elevated temperatures

Hilti bracket MQK-41/3/300 with load introduction components

Resistance at elevated temperatures

Annex C

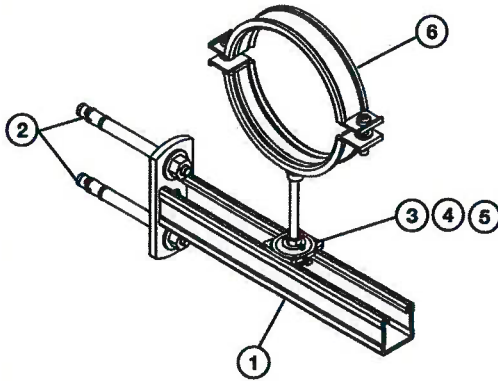

Bill of material / Stückliste					
Part of typical/ Applikationselement	Ref.	Opt.	Item no. / Artikel Nr.	Description / Bezeichnung	
Structure / Aufbau	Bracket / Konsole	1	370595	MQK-41/3/300	
	Fixation / Befestigung	2	A	2107848	HST2 M12x105 10 stud anchor
		2	B	2105718	HST3 M12x105 30/10 stud anchor
Pipe Fixation / Rohr- fixierung	M10	3	2199452	MQA-B M10 piping saddle	
		4	216466	M10 hexagon nut	
		5	339795	AM10x1000 4.8 threaded rod*	
Pipe Ring / Rohrschelle	M10	6	A	20843 - 20896	MP-MI (from 3/8" to 6", with M10)
		6	B	2172815 - 2172931	MP-L-I (10 to 170mm, with M10)

Ref. 2 bis 6 nicht Bestandteil dieser ETA / Ref. 2 to 6 not integral part of this ETA.
* Threaded rod available in 1,2 & 3 meters / Gewindestange erhältlich in 1,2 & 3 Meter

Assembly Instruction of the Application / Gebrauchsanweisung der Applikation

3 / 4 / 5

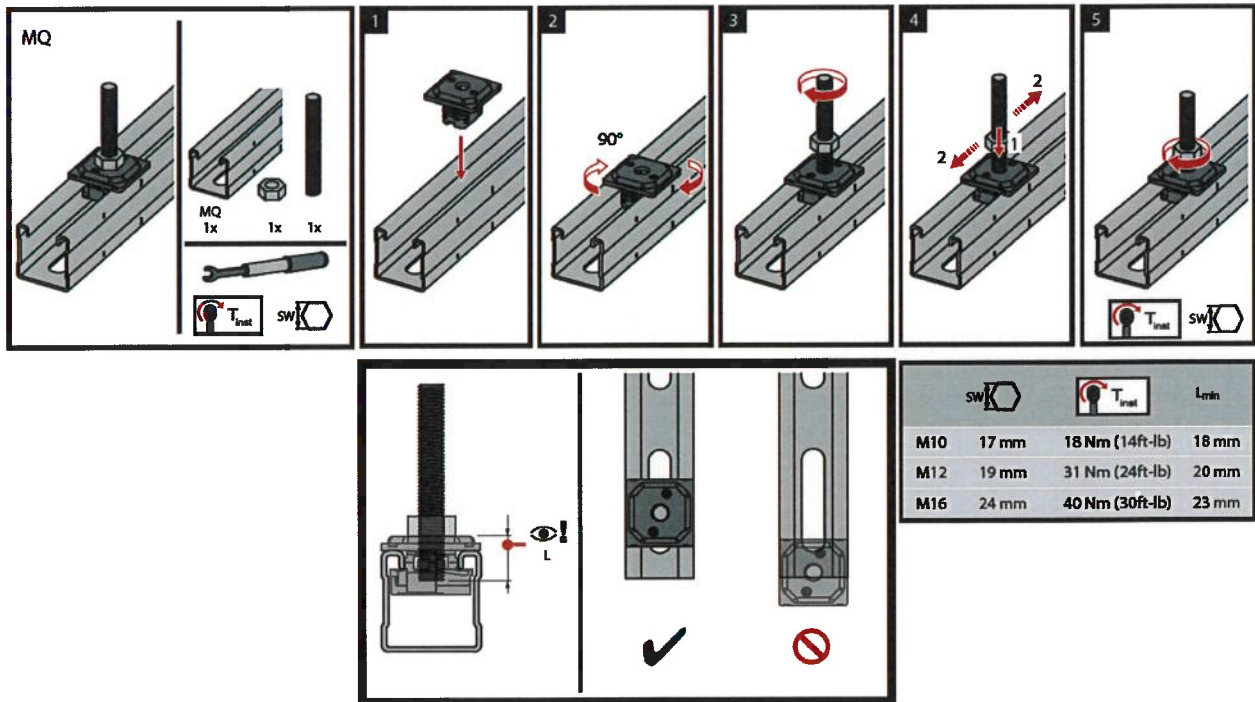

Hilti bracket MQK-41/3/300 with load introduction components

General assembly instructions

Annex D1
(informative)

6 Option A

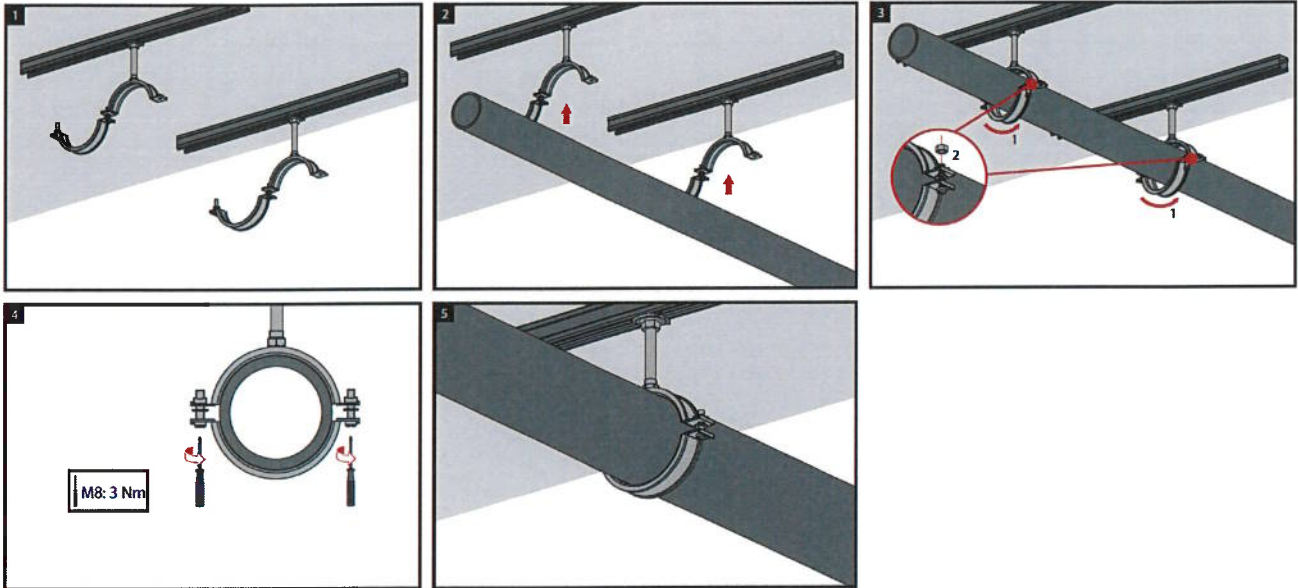

6 Option B

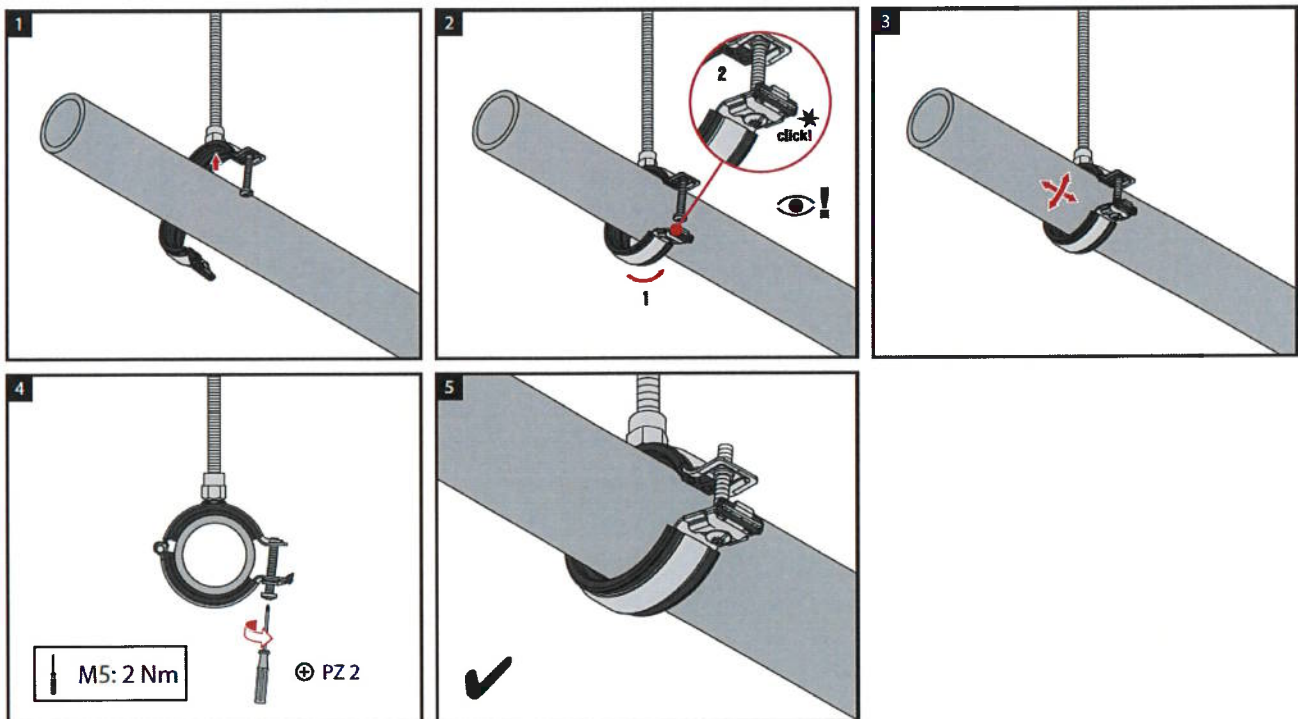

Hilti bracket MQK-41/3/300 with load introduction components

General assembly instructions

Annex D2
(informative)

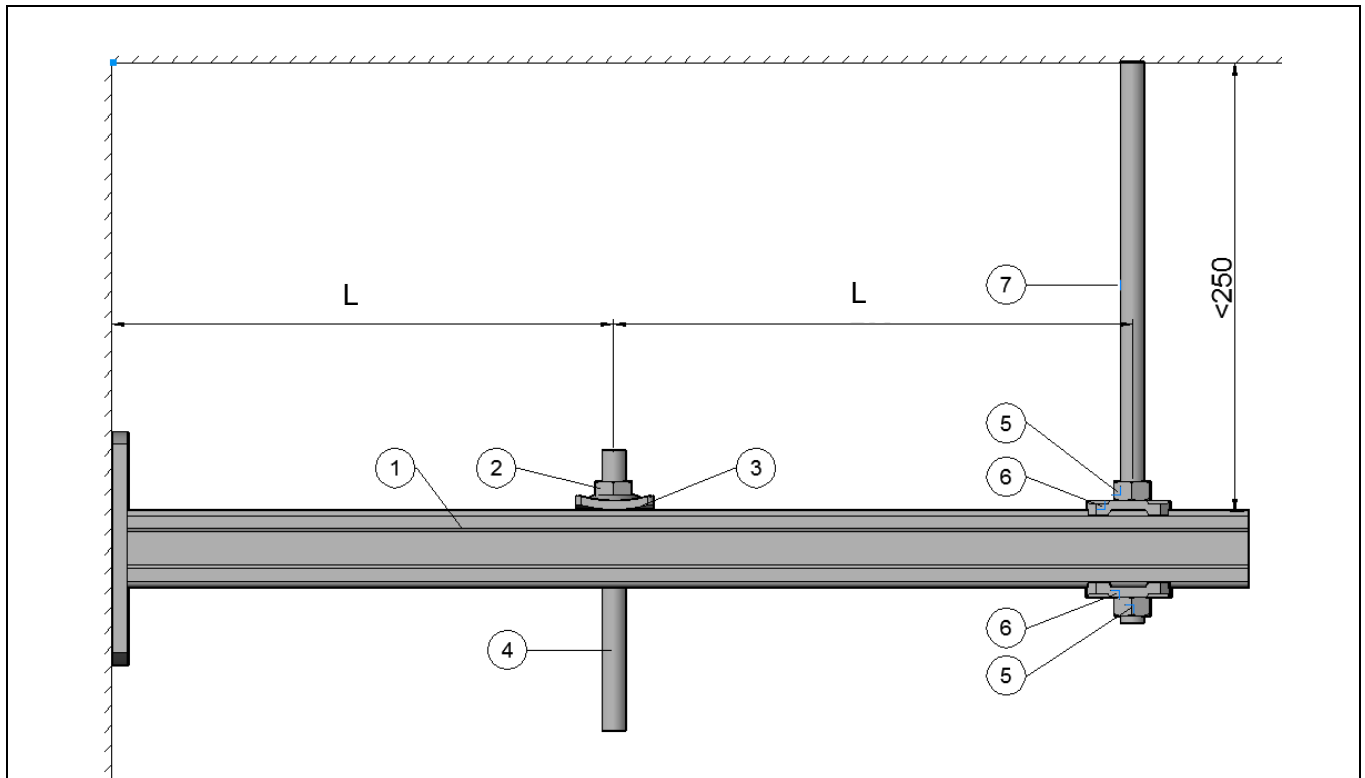

Legende

- 1 MQK-41/3/300, MQK-41/3/450 oder MQK-41/3/600
MQK-41/300, MQK-41/450 oder MQK-41/600
- 2 Hex-nut M12
- 3 MQA-M12-B
- 4 Threaded rod M12
- 5 Hex-nut M10
- 6 MQZ-L11
- 7 Threaded rod M10

L= 115 mm for MQK-41/3/300 and MQK-41/300

L= 190 mm for MQK-41/3/450 and MQK-41/450

L= 265 mm for MQK-41/3/600 and MQK-41/600

**MQK-41/3/300, MQK-41/3/450, MQK-41/3/600,
MQK-41/300, MQK-41/450, MQK-41/600 suspended**

Product description
Dimensions and materials

A1



Table C1.1: Regression curve parameter $F_{Rk,t} = c_3 (c_1 + c_2 / t)$

Brackets	c ₁	c ₂	c ₃	t _{min} [minutes]	t _{max} [minutes]
MQK-41/3/300 MQK-41/3/450 MQK-41/3/600	179.411	71910.413	0.8348	23	150

Tabelle C1.2: Resistance at elevated temperatures for centric single load

Brackets	F _{Rk,30} [N]	F _{Rk,60} [N]	F _{Rk,90} [N]	F _{Rk,120} [N]
MQK-41/3/300 MQK-41/3/450 MQK-41/3/600	2151	1150	817	650

Table C1.1: Regression curve parameter $F_{Rk,t} = c_3 (c_1 + c_2 / t)$

Brackets	c ₁	c ₂	c ₃	t _{min} [minutes]	t _{max} [minutes]
MQK-41/3/300 MQK-41/450 MQK-41/600	311.171535	58644.5383	0.64646602	30	114

Tabelle C1.2: Resistance at elevated temperatures for centric single load

Brackets	F _{Rk,30} [N]	F _{Rk,60} [N]	F _{Rk,90} [N]	F _{Rk,120} [N]
MQK-41/3/300 MQK-41/450 MQK-41/600	1465	833	611	-

MQK-41/3/300, MQK-41/3/450, MQK-41/3/600,
MQK-41/300, MQK-41/450, MQK-413/600 suspended

Performance
Characteristics at elevated temperatures

B1

Table A1.1 Dimensions and materials

Item number	Designation	L [mm]	Material channel	Material base plate
370595	MQK-41/3/300	300	t= 3 mm S235JR according to DIN EN 10025-2	S235JR according to DIN EN 10025-2
370596	MQK-41/3/450	450		
370597	MQK-41/3/600	600		
369609	MQK-41/300	300	t= 2 mm S235JR according to DIN EN 10025-2	
369610	MQK-41/450	450		
369611	MQK-41/600	600		

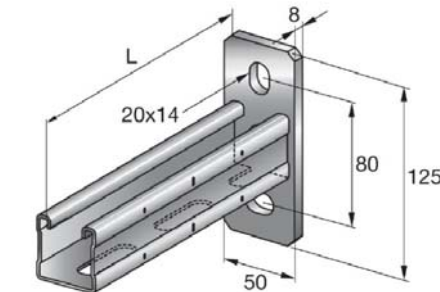

**MQK-41/3/300, MQK-41/3/450, MQK-41/3/600,
 MQK-41/300, MQK-41/450, MQK-41/600**

Product description
 Dimesions and material

A1

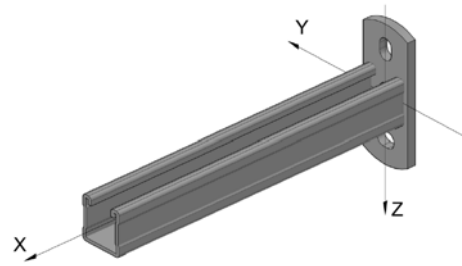

Table B1.1: Characteristic resistance: steel

$+F_{x,Rk}$ [kN]	$-F_{x,Rk}$ [kN]	$+F_{y,Rk}$ [kN]	$-F_{y,Rk}$ [kN]	$+F_{z,Rk}$ [kN]	$-F_{z,Rk}$ [kN]
18.80	38.98	10.45	10.45	31.61	31.61
$M_{x,Rk}$ [kNcm]	$M_{y,Rk}$ [kNcm]	$M_{z,Rk}$ [kNcm]			
4.63	66.74	33.09			

Tabelle B1.2: Characteristic resistance: welding

$+F_{x,Rk}$ [kN]	$-F_{x,Rk}$ [kN]	$+F_{y,Rk}$ [kN]	$-F_{y,Rk}$ [kN]	$+F_{z,Rk}$ [kN]	$-F_{z,Rk}$ [kN]
105.96	105.96	21.04	21.04	65.47	65.47
$M_{x,Rk}$ [kNcm]	$M_{y,Rk}$ [kNcm]	$M_{z,Rk}$ [kNcm]			
130.94	68.75	160.37			

provided that no other national regulations
 apply: Steel: $\gamma_{M0} = 1.0$; $\gamma_{M1} = 1.1$; $\gamma_{M2} = 1.25$
 Concrete: $\gamma_C = 1.5$, $\gamma_S = 1.15$

MQK-41/3/300, MQK-41/3/450, MQK-41/3/600

Performance
 Characteristics at ambient temperature

B1

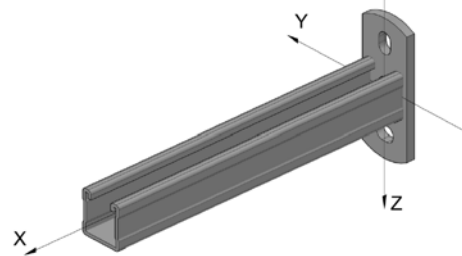

Table B2.1: Characteristic resistance: steel

$+F_{x,Rk}$ [kN]	$-F_{x,Rk}$ [kN]	$+F_{y,Rk}$ [kN]	$-F_{y,Rk}$ [kN]	$+F_{z,Rk}$ [kN]	$-F_{z,Rk}$ [kN]
18.80	38.98	7.19	7.19	21.71	21.71
$M_{x,Rk}$ [kNcm]	$M_{y,Rk}$ [kNcm]	$M_{z,Rk}$ [kNcm]			
2.20	57.03	33.09			

Tabelle B2.2: Characteristic resistance: welding

$+F_{x,Rk}$ [kN]	$-F_{x,Rk}$ [kN]	$+F_{y,Rk}$ [kN]	$-F_{y,Rk}$ [kN]	$+F_{z,Rk}$ [kN]	$-F_{z,Rk}$ [kN]
105.96	105.96	21.04	21.04	65.47	65.47
$M_{x,Rk}$ [kNcm]	$M_{y,Rk}$ [kNcm]	$M_{z,Rk}$ [kNcm]			
130.94	68.75	160.37			

provided that no other national regulations
 apply: Steel: $\gamma_{M0} = 1.0$; $\gamma_{M1} = 1.1$; $\gamma_{M2} = 1.25$
 Concrete: $\gamma_c = 1.5$, $\gamma_s = 1.15$

MQK-41/300, MQK-41/450, MQK-41/600

Performance
 Characteristics at ambient temperature

B2